



LA75675M-S

VIF/SIF IF Signal-Processing Circuit that Supports NTSC Intercarrier for TV and VCR Products

Overview

The LA75675M-S is an NTSC intercarrier VIF/SIF IC that adopts a semi-adjustment-free structure. In particular, it uses VCO adjustment to make AFT adjustment unnecessary and thus simplifies the overall adjustment process. A PLL-based technique is adopted for FM detection. The 5 V supply voltage provides compatibility with other multimedia systems. In addition it achieves high audio quality by incorporating a built-in buzz canceller that suppresses Nyquist buzz.

Functions

[VIF]

- VIF amplifier • PLL detector • BNC • RF AGC
- EQ amplifier • AFT • IF AGC • Buzz canceller

[SIF]

- Limiter amplifier • PLL FM detector

Features

- No AFT or SIF coils are used, thus eliminating adjustments.
- Excellent audio performance due to the built-in buzz canceller.
- $V_{CC} = 5\text{ V}$ and a low power dissipation of 250 mW.

Package Dimensions

unit: mm

3112A-MFP24S

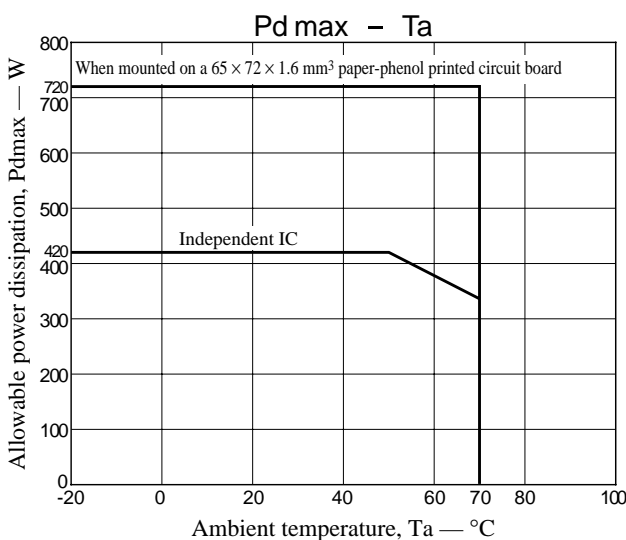
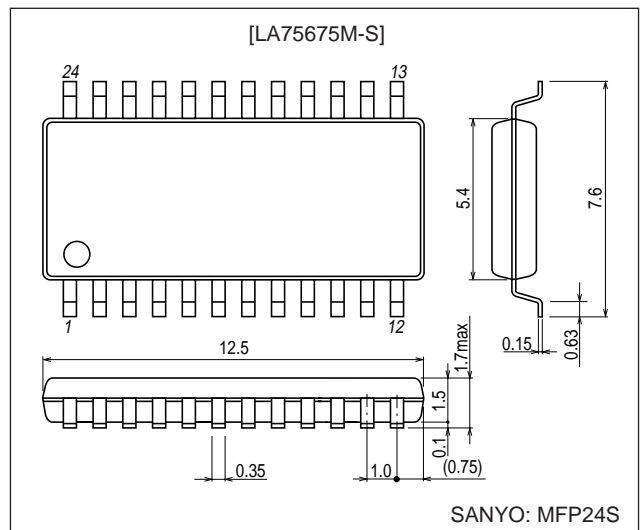

■ Any and all SANYO products described or contained herein do not have specifications that can handle applications that require extremely high levels of reliability, such as life-support systems, aircraft's control systems, or other applications whose failure can be reasonably expected to result in serious physical and/or material damage. Consult with your SANYO representative nearest you before using any SANYO products described or contained herein in such applications.

■ SANYO assumes no responsibility for equipment failures that result from using products at values that exceed, even momentarily, rated values (such as maximum ratings, operating condition ranges, or other parameters) listed in products specifications of any and all SANYO products described or contained herein.

Specifications

Maximum Ratings at $T_a = 25^\circ\text{C}$

Parameter	Symbol	Conditions	Ratings	Unit
Maximum supply voltage	V_{CC} max		6	V
Circuit voltage	V13, V17		V_{CC}	V
Circuit current	I6		-3	mA
	I10		-10	mA
	I24		-2	mA
Allowable power dissipation	Pd max	$T_a \leq 50^\circ\text{C}$, independent IC	420	mW
		*: Mounted on a PCB.	720	mW
Operating temperature	Topr		-20 to +70	$^\circ\text{C}$
Storage temperature	Tstg		-55 to +150	$^\circ\text{C}$

*: A $65 \times 72 \times 1.6$ mm³ paper-phenol printed circuit board

Operating Conditions at $T_a = 25^\circ\text{C}$

Parameter	Symbol	Conditions	Ratings	Unit
Recommended supply voltage	V_{CC}		5	V
Operating voltage range	V_{CCOP}		4.5 to 5.5	V

Electrical Characteristics at $T_a = 25^\circ\text{C}$, $V_{CC} = 5.0$ V, $f_p = 45.75$ MHz

Parameter	Symbol	Conditions	Ratings			Unit
			min	typ	max	
[VIF Block]						
Circuit current	I5		32	40	48	mA
Maximum RF AGC voltage	V14H		$V_{CC} - 0.5$	V_{CC}		V
Minimum RF AGC voltage	V14L			0	0.5	V
Input sensitivity	V_{IN}	S1 = OFF	32	38	44	dB μ V
AGC range	G_R		58	63		dB
Maximum allowable input	V_{INmax}		95	100		dB μ V
No-signal video output voltage	V6		3.5	3.8	4.1	V
Sync signal tip voltage	V6 tip		0.9	1.2	1.5	V
Video output level	V_O		1.7	2.0	2.3	Vp-p
Black noise threshold voltage	V_{BTH}		0.5	0.8	1.1	V
Black noise clamp voltage	V_{BCL}		1.6	1.9	2.2	V
Video signal-to-noise ratio	S/N		48	52		dB
C-S beating	IC-S		38	43		dB
Frequency characteristics	f_C	6 MHz	-3.0	-1.5		dB
Differential gain	DG			3.0	6.5	%
Differential phase	DP			3	5	deg
No-signal AFT voltage	V13		2.0	2.5	3.0	V
Maximum AFT voltage	V13H		4.0	4.4	5.0	V
Minimum AFT voltage	V13L		0	0.18	1.00	V
AFT detection sensitivity	Sf		28	40	52	mV/kHz
VIF input resistance	R_{IN}	45.75 MHz		1.5		k Ω
VIF input capacitance	C_{IN}	45.75 MHz		3		pF
APC pull-in range (U)	f_{PU}		1.3	2.0		MHz
APC pull-in range (L)	f			-2.0	-1.4	MHz
AFT tolerance frequency 1	dfa 1		-150	0	+150	kHz
VCO 1 maximum variability range (U)	dfu		1.5	2.0		MHz
VCO 1 maximum variability range (L)	dfl			-2.0	-1.5	MHz
VCO control sensitivity	B		1.3	2.7	5.4	kHz/mV

Continued on next page.

LA75675M-S

Continued from preceding page.

Parameter	Symbol	Conditions	Ratings			Unit
			min	typ	max	
[SIF Block]						
Limiting sensitivity	V _{li} (lim)		39	45	51	dB μ V
FM detection output voltage	V _O (FM)	4.5 MHz \pm 25 kHz *1	400	520	660	mVrms
AMR rejection ratio	AMR		50	60		dB
Total harmonic distortion	THD			0.3	0.8	%
SIF signal-to-noise ratio	S/N (FM)		59	64		dB
4.5 MHz output level	V _{sout}	SIF IN 80 dB μ V	82	89	96	dB μ V

Note: 1. The FM detection output level can be reduced and the FM dynamic range improved by inserting the resistor R in series with the capacitor between pin 23 and ground.

Pin Arrangement

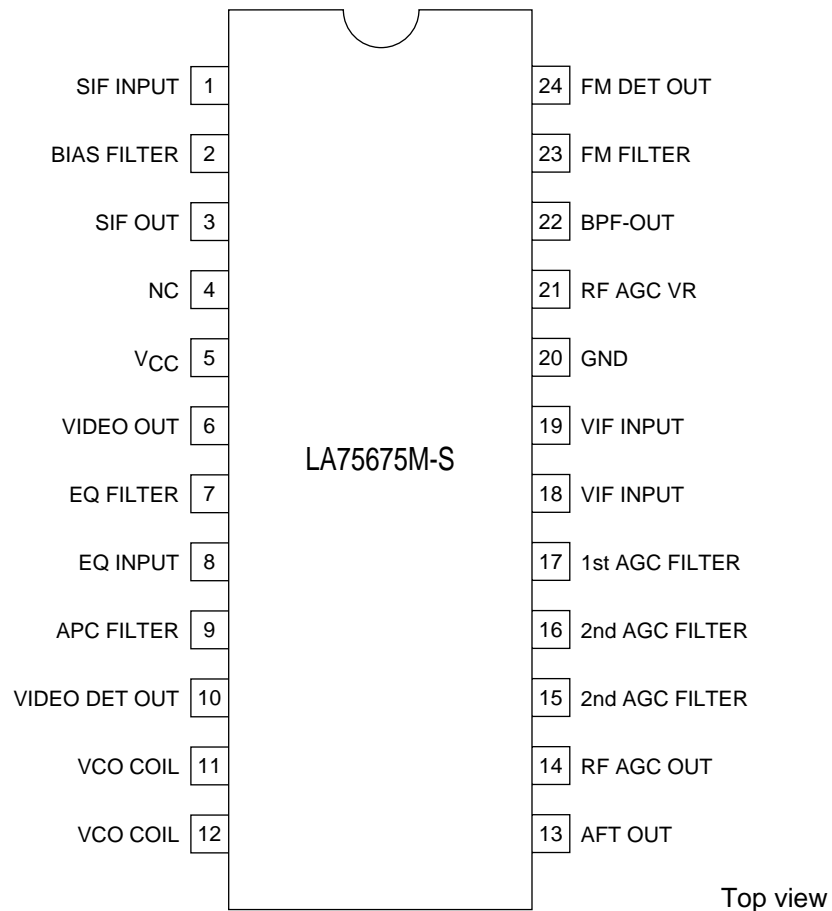

A12615

Internal Equivalent Circuit and External Circuits

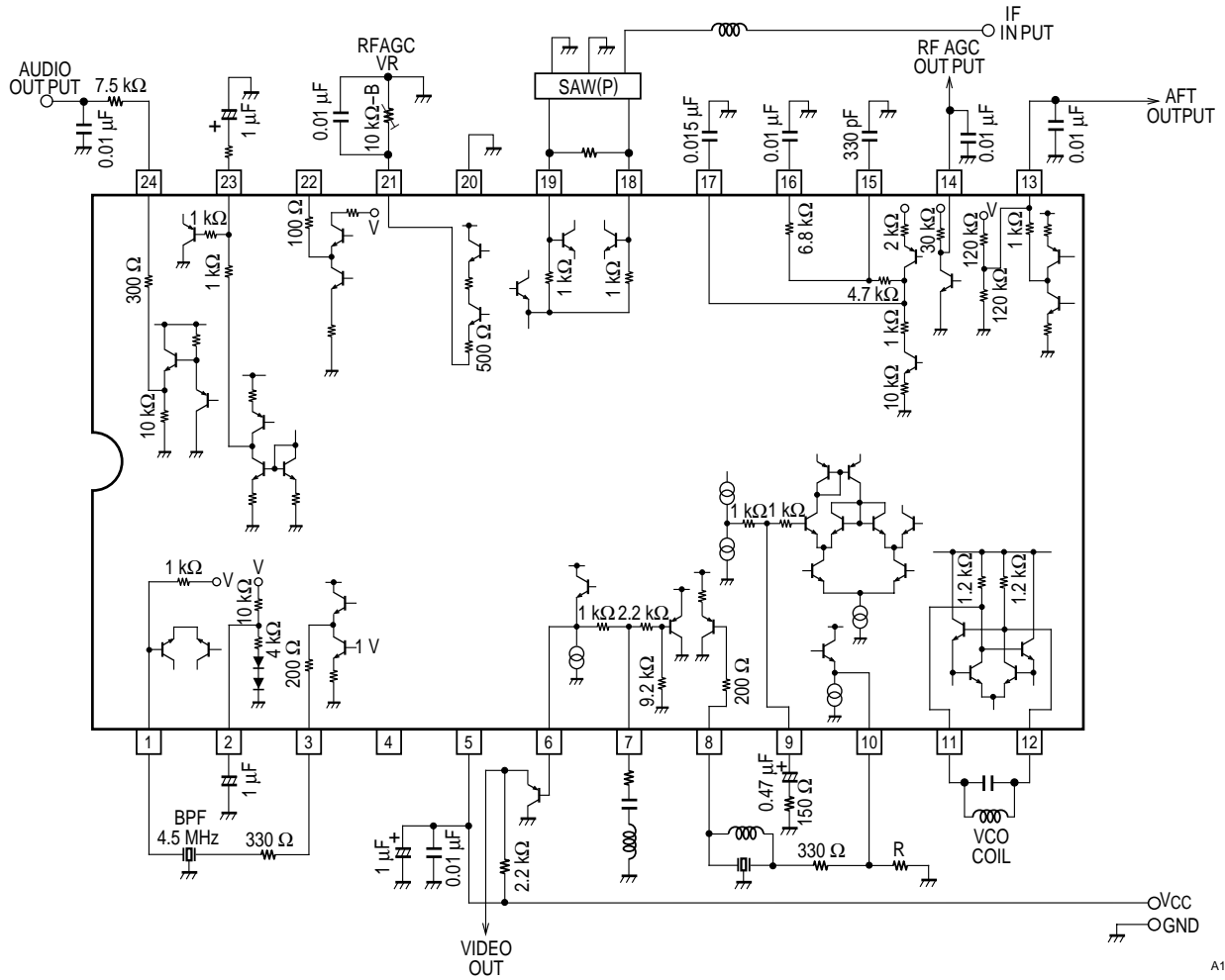

A12616

Note: Resistor R must have a value of 470 Ω or larger.

LA75675M-S

AC Characteristics Test Circuit

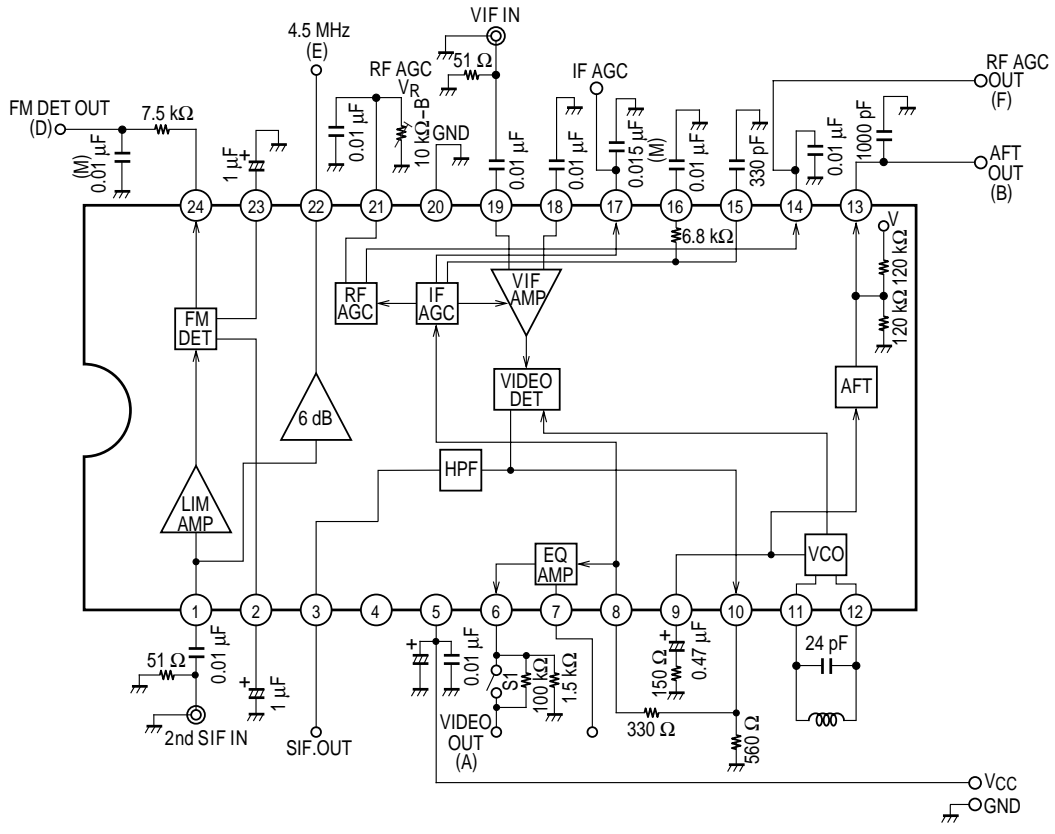

A12617

Test Circuit

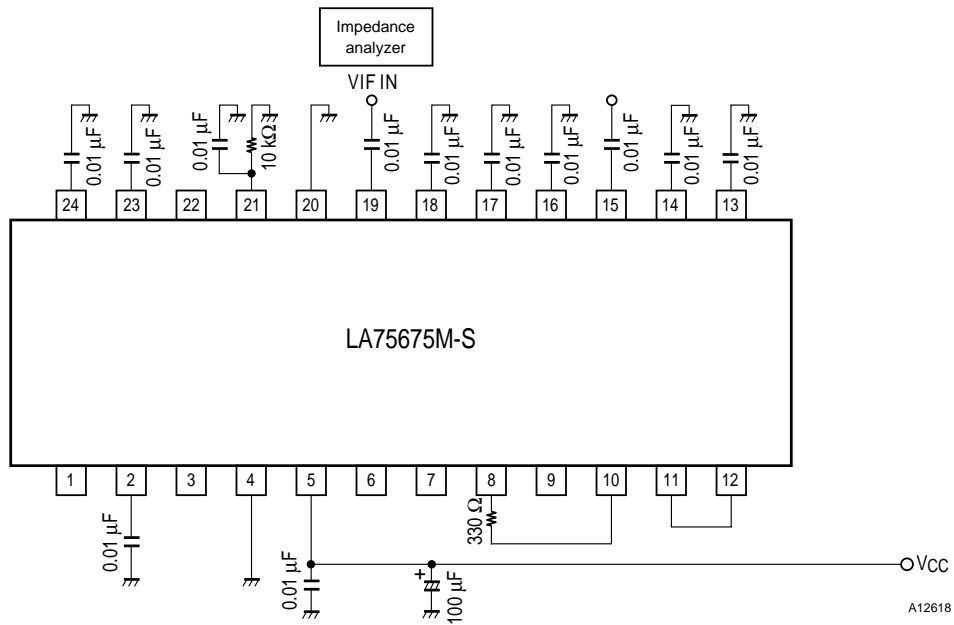

A12618

LA75675M-S

Sample Application Circuit

NTSC

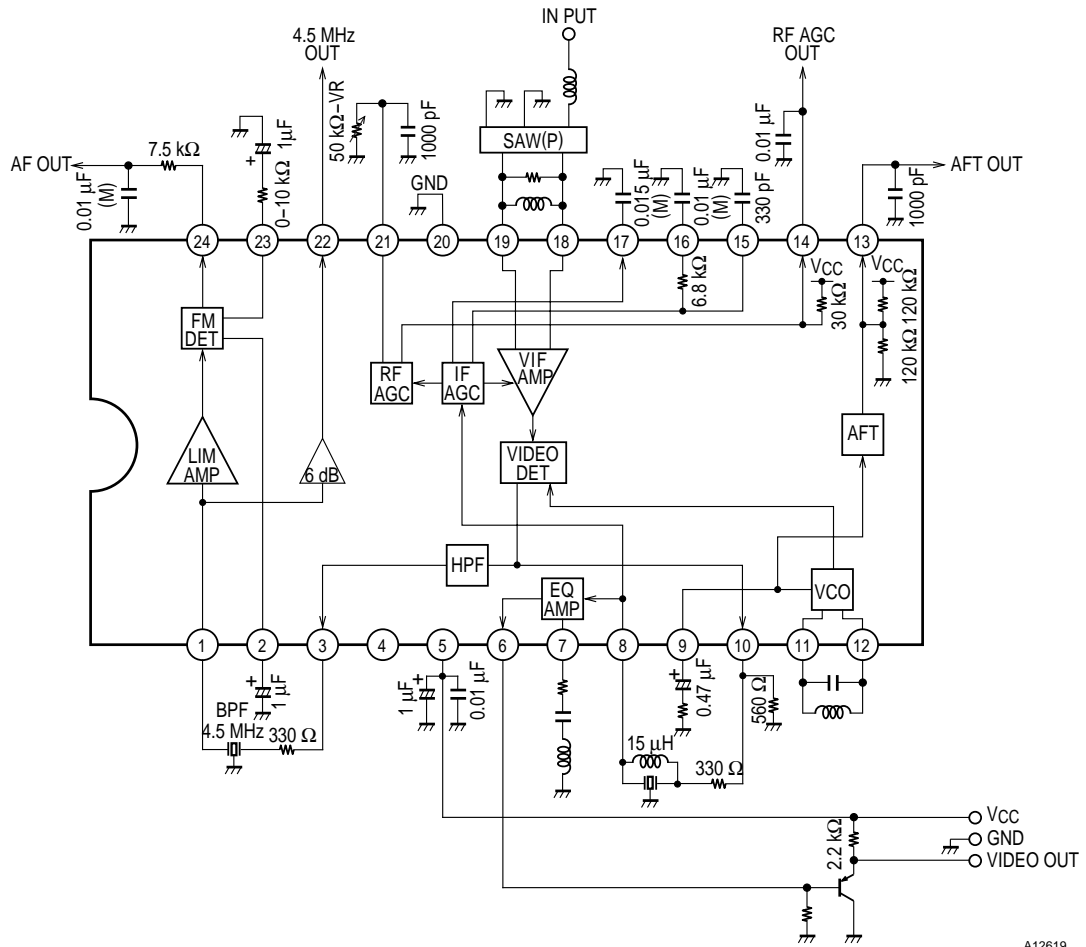

A12619

LA75675M-S

Pin Functions

Pin No.	Pin	Function	Equivalent circuit
1	SIF input	<p>SIF input</p> <p>The input impedance is about 1 kΩ.</p> <p>Since interference signals* entering this input can result in buzzing and beat signals, the pattern layout for the signal input to this pin must be designed carefully.</p> <p>*: Signals that can interfere with audio include video and chrominance signals. Thus the VIF carrier signal can cause interference.</p>	<p>A12620</p>
2	FM power supply filter	<p>The FM detector signal-to-noise ratio can be improved by inserting a filter in the FM detector bias line.</p> <p>C1 must be 0.47 μF or higher, and we recommend 1 μF.</p> <p>If the FM detector is not used, a 2 kΩ resistor must be inserted between pin 2 and ground. This stops the FM detector VCO circuit.</p>	<p>A12621</p>
3	SIF out	<p>Outputs the intercarrier detector output that has been passed through a high-pass filter.</p> <p>(4.5 MHz output)</p>	<p>A12622</p>
4	NC	This pin should be left open.	
5	V _{CC}	Use lines that are as short as possible for V _{CC} /ground decoupling.	

Continued on next page.

Continued from preceding page.

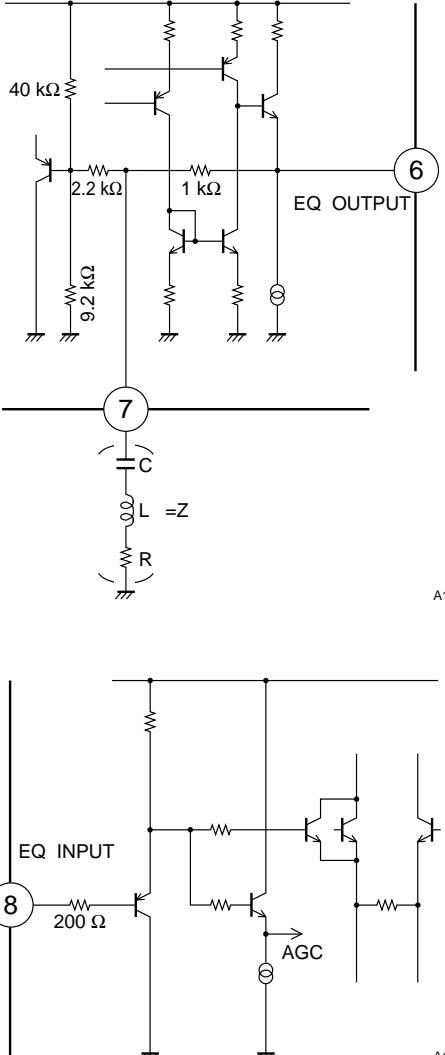
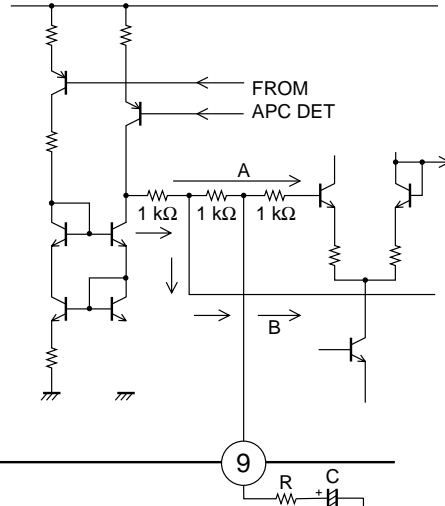
Pin No.	Pin	Function	Equivalent circuit
6 7 8	EQ amp	<p>Equalizer circuit</p> <p>This circuit corrects the frequency characteristics of the video signal.</p> <p>Pin 8 is the input to the EQ amplifier. The EQ amplifier takes a 1.5 Vp-p video signal as its input and amplifies that to a 2.0 Vp-p level.</p> <ul style="list-style-type: none"> Notes on the equalizer amplifier design <p>The equalizer amplifier is designed as a voltage follower amplifier with a gain of about 2.3 dB. If frequency characteristics correction is required, insert the capacitor, inductor, and resistor between pin 7 and ground in series.</p> <ul style="list-style-type: none"> Using the equalizer amplifier <p>If the input signal is v_i and the output signal v_o, then</p> $\frac{R1}{Z} + 1 \quad (V_i + V_{in}) = V_o \times G$ <p>G: Gain of the voltage follower amplifier V_{in}: Imaginary voltage G: About 2.3 dB</p> <p>Assuming $V_{in} \approx 0$, then AV will be:</p> $AV = \frac{V_o G}{V_i} = \frac{R1}{Z} + 1$ <p>R1 is an IC internal 1 kΩ resistor. Simply select a value of Z according to the desired characteristics. However, note that the equalizer amplifier gain will be a maximum at the Z resonance, so care is required to prevent distortion from occurring.</p>	 <p style="text-align: right;">A12623</p> <p style="text-align: right;">A12624</p>
9	APC filter	<p>PLL detector APC filter connection</p> <p>The APC time constant is switched internally by the IC. When locked, the VCO is controlled by the route A, and the gain is reduced. When unlocked or during weak field reception, the VCO is controlled by the route B, and the gain is increased.</p> <p>We recommend the following values for this APC filter:</p> <p>R = 150 to 390 Ω C = 0.47 μF.</p>	 <p style="text-align: right;">A12625</p>

Continued on next page.

LA75675M-S

Continued from preceding page.

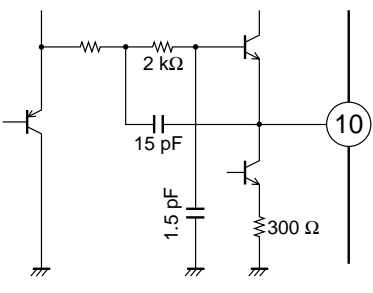
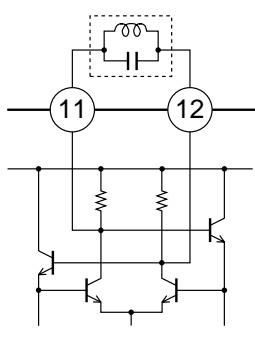
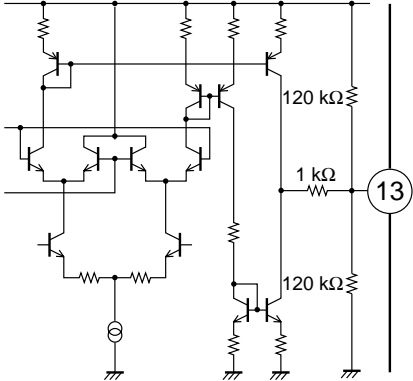
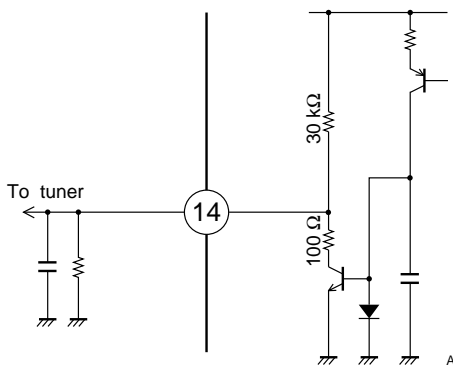
Pin No.	Pin	Function	Equivalent circuit
10	Composit video output	Outputs a video signal that includes the SIF carrier. A resistor must be inserted between pin 10 and ground to acquire adequate drive capability. $R \geq 470 \Omega$	 <p style="text-align: right;">A12626</p>
11 12	VCO tank	VCO tank circuit for video detection See the separately provided coil specifications for details on the tank circuit. This VCO is a vector synthesis VCO circuit.	 <p style="text-align: right;">A12627</p>
13	AFT output	AFT output This circuit includes a function that controls the AFT voltage so that it naturally goes to the center voltage during weak field reception. A 120 kΩ bleeder resistor is built in. Note that the sensitivity can be lowered by attaching an external resistor.	 <p style="text-align: right;">A12628</p>
14	RF AGC output	RF AGC output This output controls the tuner RF AGC. The internal circuit includes both a 30 kΩ pull-up resistor and a 100 Ω protective resistor. Determine the value of the external bleeder resistor to match the specifications of the tuner.	 <p style="text-align: right;">A12629</p>

Continued on next page.

LA75675M-S

Continued from preceding page.

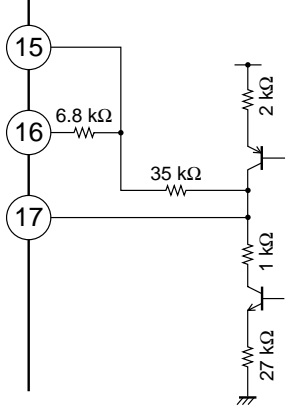
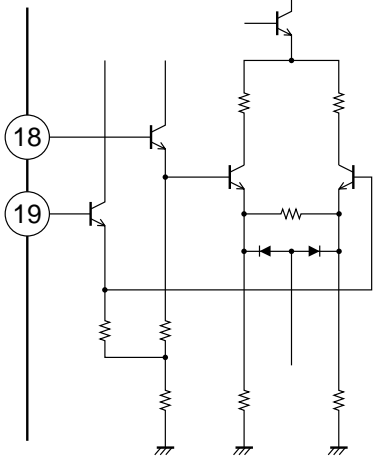
Pin No.	Pin	Function	Equivalent circuit
15 16 17	AGC filter	<p>IF AGC filter connection</p> <p>The AGC voltage is created by smoothing the signal that results from peak detection by the AGC detector at pins 17 (first AGC), and 15 and 16 (second AGC). The video signal input to this IF AGC detector is a signal that was passed through the audio trap circuit.</p>	 <p style="text-align: right;">A12630</p>
18 19	VIF input	<p>VIF amplifier input</p> <p>The input circuit is a balanced input, and its input impedance is due to the following component values.</p> <p>$R = 1.5 \text{ k}\Omega$</p> <p>$C = 3 \text{ pF}$</p>	 <p style="text-align: right;">A12631</p>
20	GND		

Continued on next page.

LA75675M-S

Continued from preceding page.

Pin No.	Pin	Function	Equivalent circuit
21	RF AGC VR	<p>RF AGC adjustment</p> <p>This pin sets the tuner's RF AGC operating point. Both the FM output and the video output can be muted by setting this pin to the ground level.</p>	<p style="text-align: right;">A12632</p>
22	BPF-out	<p>Bandpass filter output</p> <p>The output to the external bandpass filter is passed through an internal 6 dB amplifier before being output.</p>	<p style="text-align: right;">A12633</p>
23	FM filter	<p>Filter that holds the FM detector output DC voltage fixed.</p> <p>Normally, a 1 μF electrolytic capacitor is used. If the low band (around 50 Hz) frequency characteristics are of concern, this value should be increased. The FM detection output level can be reduced and the FM dynamic range improved by inserting the resistor R in series with the capacitor between pin 23 and ground.</p>	<p style="text-align: right;">A12634</p>
24	FM detector output	<p>Audio FM detector output</p> <p>This is an emitter-follower circuit with a 300 Ω resistor inserted in series.</p> <ul style="list-style-type: none"> • Stereo applications In some applications that provide input to a stereo decoder, the input impedance may be reduced, resulting in distortion in the L-R signal and degraded stereo characteristics. If this problem occurs, add a resistor between pin 24 and ground. $R1 \geq 5.1 \text{ k}\Omega$ • Mono applications Construct an external deemphasis circuit. $t = CR2$ 	<p style="text-align: right;">A12635</p>

Notes on Sanyo SAW Filters

There are two types of SAW filters, which differ in the piezoelectric substrate material used, as follows:

- Lithium tantalate (LiTaO₃) SAW filter

TSF11□□ ... Japan
 TSF12□□ ... US

Although lithium tantalate SAW filters have the low temperature coefficient of $-18 \text{ ppm}/^\circ\text{C}$, they suffer from a large insertion loss. However, it is possible, at the cost of increasing the number of external components required, to minimize this insertion loss by using a matching circuit consisting of coils and other components at the SAW filter output. At the same time as minimizing insertion loss, this technique also allows the frequency characteristics, level, and other aspects to be varied, and thus provides increased circuit design flexibility. Also, since the SAW filter reflected wave level is minimal, the circuit can be designed with a low in-band ripple level.

- Lithium niobate (LiNbO₃) SAW filter

TSF52□□ ... US
 TSF53□□ ... PAL

Although lithium niobate SAW filters have the high temperature coefficient of $-72 \text{ ppm}/^\circ\text{C}$, they feature an insertion loss about 10 dB lower than that of lithium tantalate SAW filters. Accordingly, there is no need for a matching circuit at the SAW filter output. Although the in-band ripple is somewhat larger than with lithium tantalate SAW filters, since they have a low impedance and a small field slew, they are relatively immune to influences from peripheral circuit components and the geometry of the printed circuit board pattern. This allows stable out-of-band trap characteristics to be acquired. Due to the above considerations, lithium tantalate SAW filters are used in applications for the US and Japan that have a high IF frequency, and lithium niobate SAW filters are used in PAL and US applications that have a low IF frequency.

Notes on SAW Filter Matching

In SAW filter input circuit matching, rather than matching the IF frequency, flatter video band characteristics can be acquired by designing the tuning point to be in the vicinity of the audio carrier rather than near the chrominance carrier. The situation shown in figure on the right makes it easier to acquire flat band characteristics than that in figure on the left.

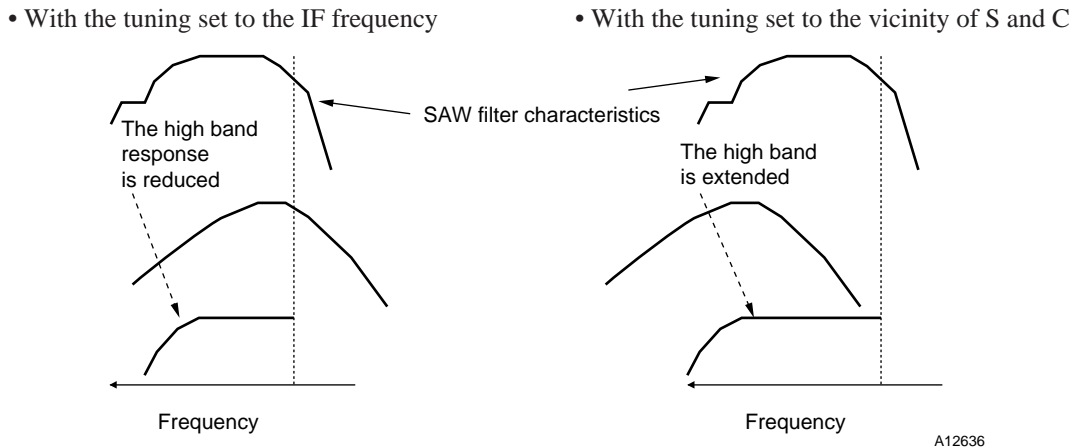

Coil Specifications

	JAPAN f = 58.75 MHz	US f = 45.75 MHz	PAL f = 38.9 MHz
VCO coil	<p>t = 5 t 0.12 ϕ C = 24 pF</p> <p>A12637</p> <p>Prototype no. V291XCS-3220Z The Toko Electric Corporation</p>	<p>t = 6 t 0.12 ϕ C = 24 pF</p> <p>A12638</p> <p>Prototype no. 291XCS-3188Z The Toko Electric Corporation</p>	<p>t = 7 t 0.12 ϕ C = 24 pF</p> <p>A12639</p> <p>Prototype no. 292GCS-7538Z The Toko Electric Corporation</p>
SAW filter (SPLIT)	Picture TSF1137U Sound	Picture TSF1241 Sound	Picture TSF5315 Sound
SAW filter (INTER)		TSF5220, TSF5221	TSF5321, TSF5344

The Toko Electric Corporation 2-1-17 Higashi Yukigaya Ota-ku, Tokyo Telephone: +81-3-3727-1167

Notes on VCO Transformer Circuits

- Built-in capacitor VCO transformer circuits

When power is first applied, the heat generated by the IC is transmitted through the printed circuit board to the VCO transformer. However, the VCO coil frame functions as a heat sink and dissipates the heat from the IC. As a result, it is relatively difficult to transmit heat to the VCO transformer's built-in capacitor, and drift at power on is minimal. Therefore, it suffices to design the circuit so that the coil and capacitor thermal characteristics cancel. Ideally, it is better to use a coil with a core material that has low temperature coefficient characteristics.

- External capacitor VCO transformer circuits

When an external capacitor is used, the heat generated by the IC is transmitted through the printed circuit board directly to the VCO tank circuit external capacitor. While this capacitor is heated relatively early after power is applied, the coil is not influenced as much by this heat, and as a result, the power-on drift is larger. Accordingly, a coil whose core material has low temperature coefficient characteristics must be used. It is also desirable to use a capacitor with similarly low temperature coefficient characteristics.

Note: Applications that use an external capacitor here must use a chip capacitor. If an ordinary capacitor is used, problems such as the oscillator frequency changing with the capacitor orientation may occur.

- Specifications of any and all SANYO products described or contained herein stipulate the performance, characteristics, and functions of the described products in the independent state, and are not guarantees of the performance, characteristics, and functions of the described products as mounted in the customer's products or equipment. To verify symptoms and states that cannot be evaluated in an independent device, the customer should always evaluate and test devices mounted in the customer's products or equipment.
- SANYO Electric Co., Ltd. strives to supply high-quality high-reliability products. However, any and all semiconductor products fail with some probability. It is possible that these probabilistic failures could give rise to accidents or events that could endanger human lives, that could give rise to smoke or fire, or that could cause damage to other property. When designing equipment, adopt safety measures so that these kinds of accidents or events cannot occur. Such measures include but are not limited to protective circuits and error prevention circuits for safe design, redundant design, and structural design.
- In the event that any or all SANYO products (including technical data, services) described or contained herein are controlled under any of applicable local export control laws and regulations, such products must not be exported without obtaining the export license from the authorities concerned in accordance with the above law.
- No part of this publication may be reproduced or transmitted in any form or by any means, electronic or mechanical, including photocopying and recording, or any information storage or retrieval system, or otherwise, without the prior written permission of SANYO Electric Co., Ltd.
- Any and all information described or contained herein are subject to change without notice due to product/technology improvement, etc. When designing equipment, refer to the "Delivery Specification" for the SANYO product that you intend to use.
- Information (including circuit diagrams and circuit parameters) herein is for example only; it is not guaranteed for volume production. SANYO believes information herein is accurate and reliable, but no guarantees are made or implied regarding its use or any infringements of intellectual property rights or other rights of third parties.

This catalog provides information as of May, 2000. Specifications and information herein are subject to change without notice.