

<b>SANYO</b>	No.3795A	<b>LA8615M, LA8615V</b>
	<b>Narrowband FM IF Amplifiers for Pager Receivers</b>	

**OVERVIEW**

The LA8615M and LA8615V are narrowband FM IF amplifier and detector ICs that feature extremely low power consumption, making them ideal for pager receivers.

The LA8615M and LA8615V incorporate an IF amplifier, an adjustment-free quadrature detector, a buffer amplifier for a lowpass filter, a frequency-shift key (FSK) wave shaper with threshold hold circuitry, battery save and check functions and a voltage regulator.

The LA8615M and LA8615V operate from a 1.0 to 5.0 V supply and are available in 16-pin MFPs and 16-pin SSOPs, respectively.

**FEATURES**

- Narrowband IF amplifier
- Adjustment-free quadrature detector
- Buffer amplifier for lowpass filter
- FSK wave shaper
- Threshold hold circuitry
- Battery save function
- Battery check function
- 1.0 V regulator
- 700  $\mu$ A supply current
- 1.0 to 5.0 V supply
- 16-pin MFP (LA8615M) and 16-pin SSOP (LA8615V)

**PINOUT**

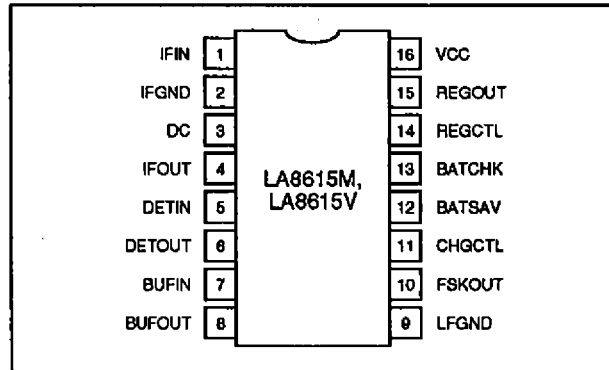

**PACKAGE DIMENSIONS**

Unit: mm

**3161-MFP16S (LA8615M)**

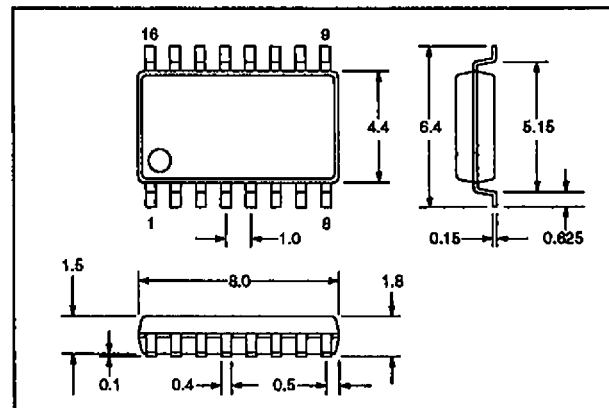

**3178-SSOP16 (LA8615V)**

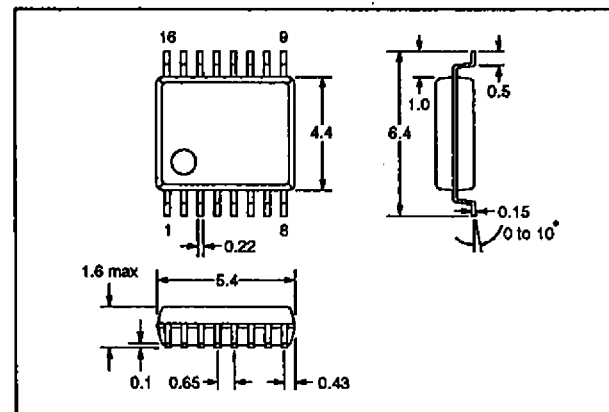

**BLOCK DIAGRAM**

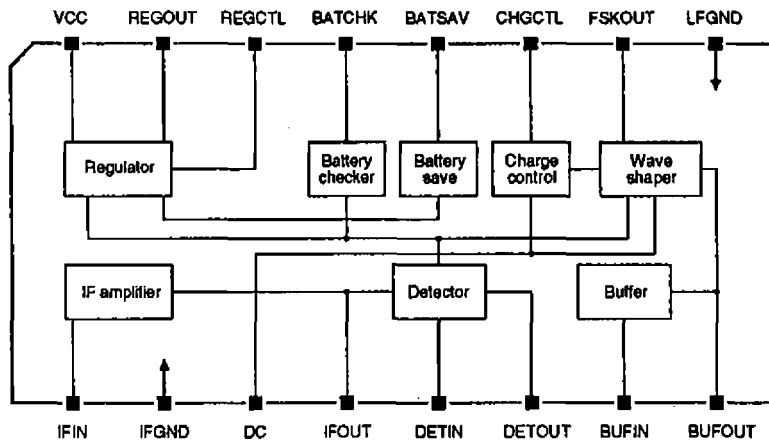

**SCHEMATIC DIAGRAM**

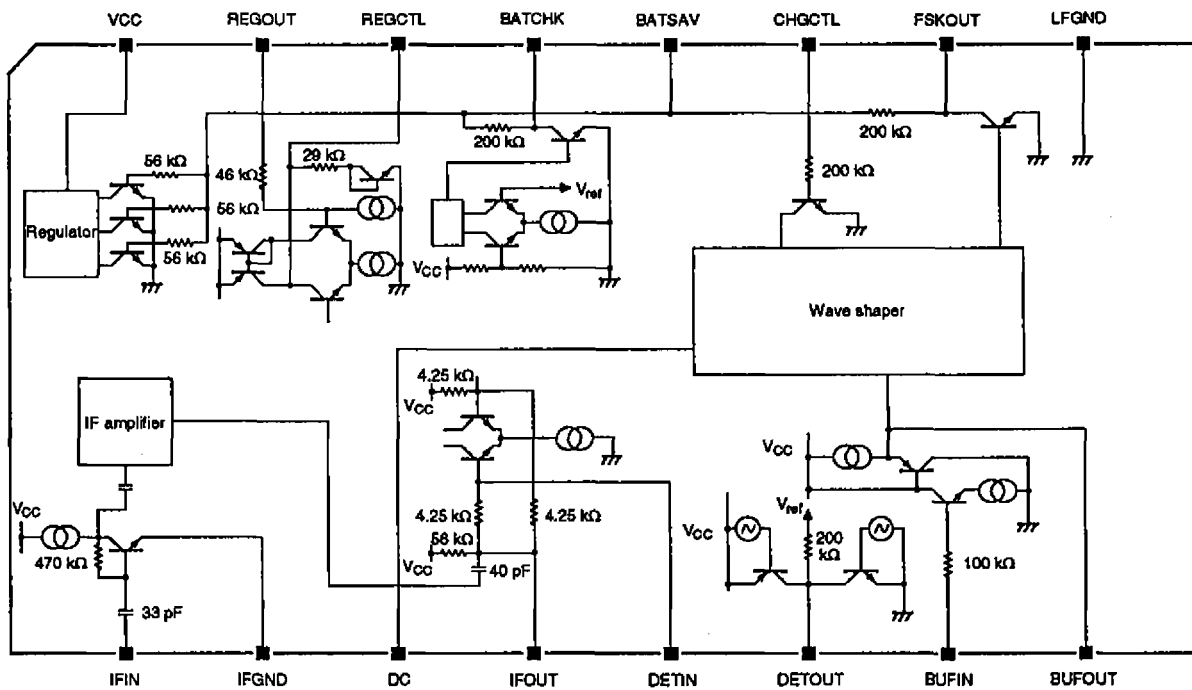

**PIN DESCRIPTION**

Number	Name	Description
1	IFIN	IF signal input
2	IFGND	IF ground
3	DC	Detector center voltage capacitor connection. Nominal voltage is 0.8 V.
4	IFOUT	IF output. Nominal voltage is 1.4 V.
5	DETIN	Detector input. Nominal voltage is 1.4 V.
6	DETOUT	Detector output. Nominal voltage is 0.8 V.
7	BUFIN	Buffer amplifier input. Nominal voltage is 0.8 V.
8	BUFOUT	Buffer amplifier output. Nominal voltage is 0.8 V.
9	LFGND	LF ground
10	FSKOUT	Frequency-shift key wave shaper output. Nominal voltage is 0 or 1.4 V.
11	CHGCTL	Charge control input
12	BATSAV	Battery save control input
13	BATCHK	Battery checker output. Nominal voltage is 0 or 1.4 V.
14	REGCTL	Regulator transistor control. Nominal voltage is 0.7 V.
15	REGOUT	Regulator output sense input. Nominal voltage is 1.0 V.
16	VCC	1.0 to 5.0 V supply

**SPECIFICATIONS****Absolute Maximum Ratings**

Parameter	Symbol	Rating	Unit
Supply voltage	$V_{CC}$	6	V
BATSAV input voltage	$V_i$	6	V
Power dissipation	$P_D$	300	mW
Operating temperature range	$T_{opr}$	-20 to 70	°C
Storage temperature range	$T_{stg}$	-40 to 125	°C

**Recommended Operating Conditions** $T_a = 25\text{ °C}$ 

Parameter	Symbol	Rating	Unit
Supply voltage	$V_{CC}$	1.4	V
Supply voltage range	$V_{CC}$	1.0 to 5.0	V

**Electrical Characteristics**

$V_{CC} = 1.4 \text{ V}$ ,  $T_a = 25 \text{ }^\circ\text{C}$ ,  $f_c = 455 \text{ kHz}$ ,  $f_m = 600 \text{ Hz}$ ,  $\pm 4.5 \text{ kHz}$  deviation, 30% modulation

Parameter	Symbol	Condition	Rating			Unit
			min	typ	max	
Operating supply current	$I_{CC1}$	No input, $V_{I1} = 0 \text{ V}$ , $V_{I2} = 1.4 \text{ V}$	-	0.7	1.0	mA
Standby supply current	$I_{CC2}$	No input, $V_{I1} = V_{I2} = 0 \text{ V}$	-	-	1	$\mu\text{A}$
-3 dB limiting sensitivity	-3 dBLS	$V_i = 80 \text{ dB}\mu$ reference, -3 dB input	30	26	-	$\text{dB}\mu$
Demodulator rms output voltage	$V_O$	$V_i = 80 \text{ dB}\mu$	30	50	-	mV
Total harmonic distortion	THD	$V_i = 80 \text{ dB}\mu$	-	1.0	4.0	%
Signal-to-noise ratio	S/N	$V_i = 80 \text{ dB}\mu$	40	50	-	dB
		$V_i = 21 \text{ dB}\mu$	8	-	-	
AM rejection ratio	AMR	$V_i = 80 \text{ dB}\mu$	30	40	-	dB
Wave shaper LOW-level output voltage	$V_L$	$V_a = 0.8 \text{ V}$ , $V_b = 1.1 \text{ V}$ , $V_{I1} = V_{I2} = 1.4 \text{ V}$	-	-	0.15	V
Wave shaper HIGH-level output voltage	$V_H$	$V_a = 0.8 \text{ V}$ , $V_b = 0.5 \text{ V}$ , $V_{I1} = V_{I2} = 1.4 \text{ V}$	1.0	-	-	V
Duty cycle	Duty		43	50	57	%
Battery checker threshold voltage	$V_{Batt}$		1.03	1.10	1.17	V
Regulator output voltage	$V_{Reg}$	$V_{CC} = 1.1 \text{ V}$ , $R_L = 200 \Omega$	0.93	1.00	1.07	V

**Measurement Circuit**

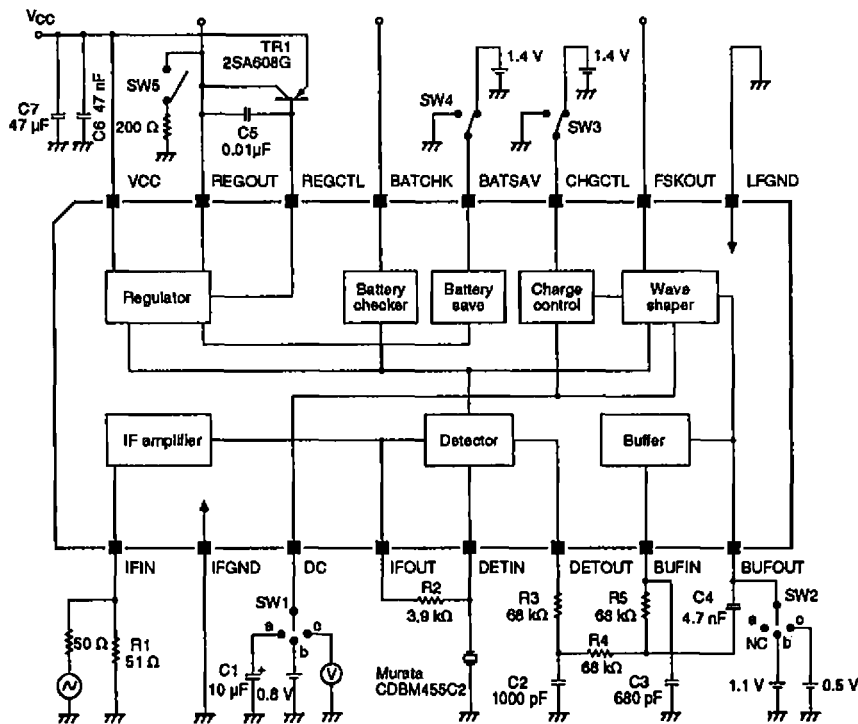

Typical Performance Characteristics

Output voltage vs. Input voltage (with THD and AMR)

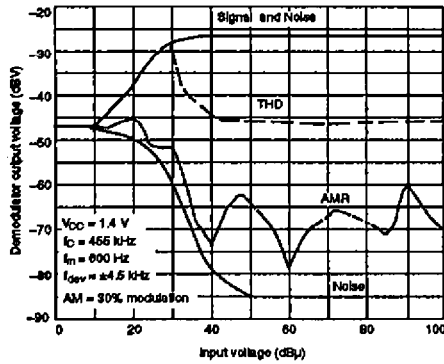

-3 dB limiting sensitivity vs. supply voltage

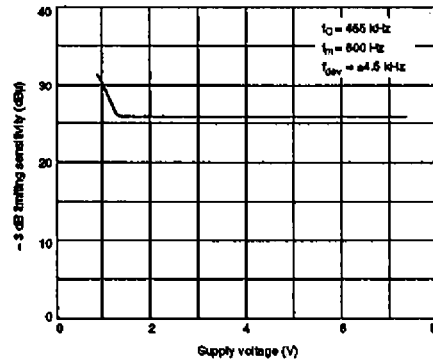

Discriminator output voltage vs. separation frequency

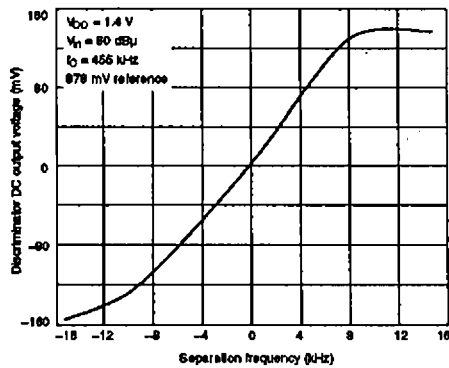

Output voltage vs. supply voltage

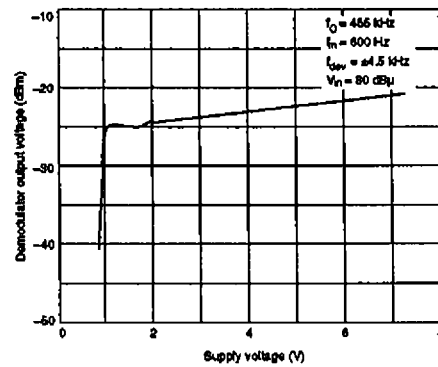

Total harmonic distortion vs. separation frequency

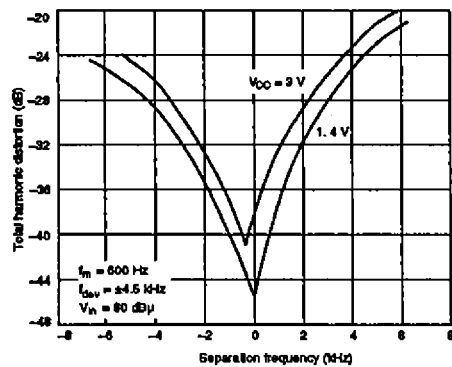

Wave shaper duty cycle vs. supply voltage

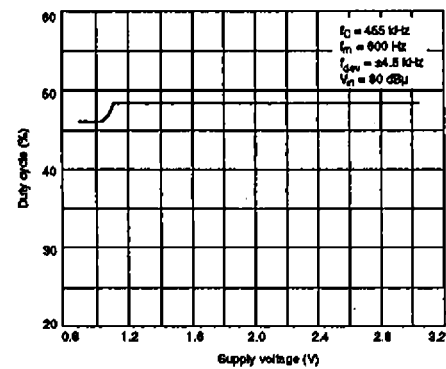

Regulator output voltage vs. supply voltage

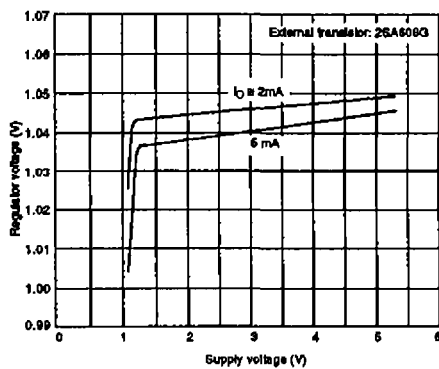

Lowpass filter frequency response

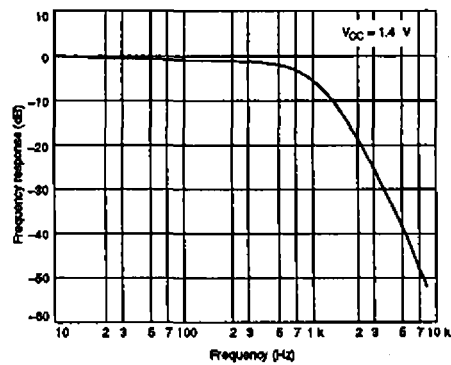

Supply current vs. input voltage (1)

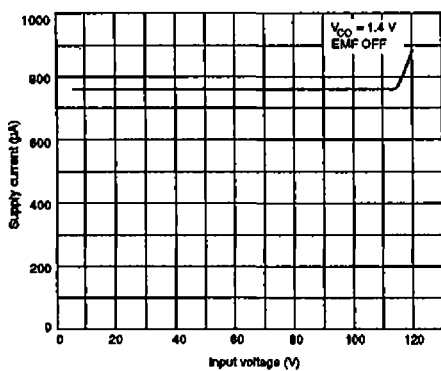

Charge current vs. bias resistance

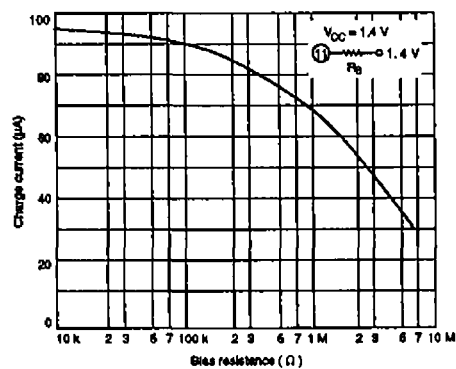

Supply current vs. input voltage (2)

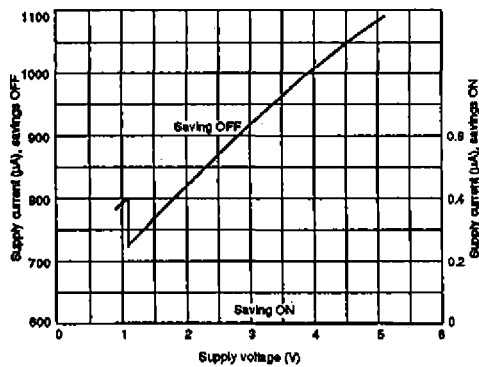

-3 dB limiting sensitivity vs. ambient temperature

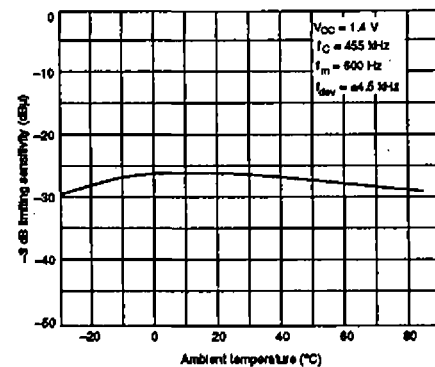

Battery checker output vs. supply voltage

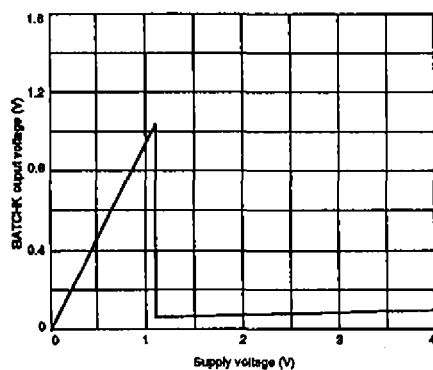

Regulator output vs. ambient temperature

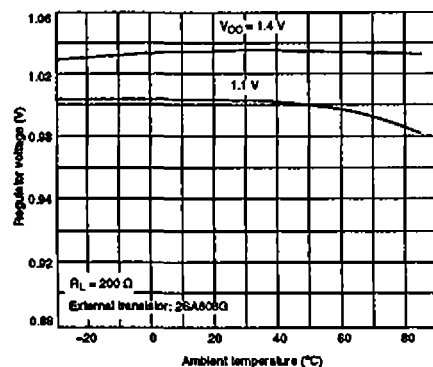

Output voltage, noise voltage, AM rejection and THD vs. ambient temperature

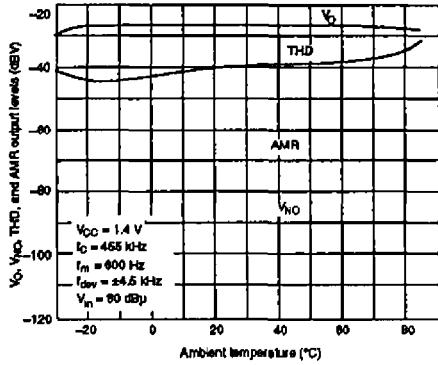

Discriminator output voltage vs. separation frequency

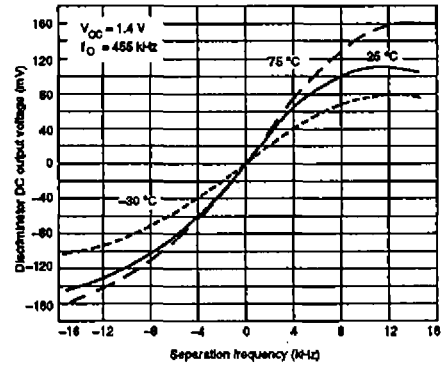

Output voltage vs. input voltage

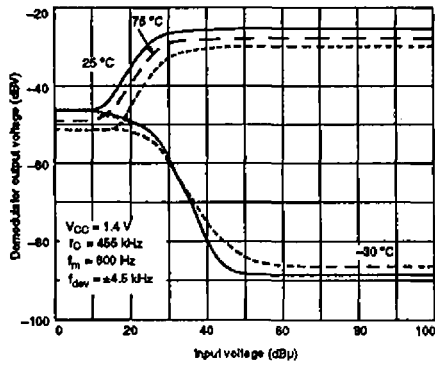

Quiescent supply current vs. ambient temperature

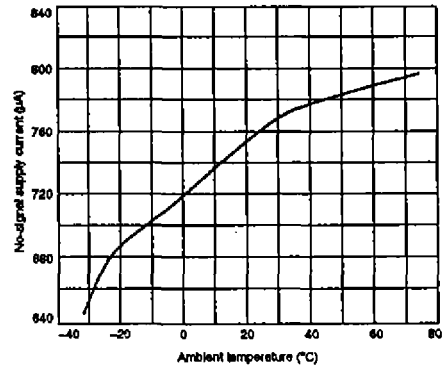

Tuning characteristics

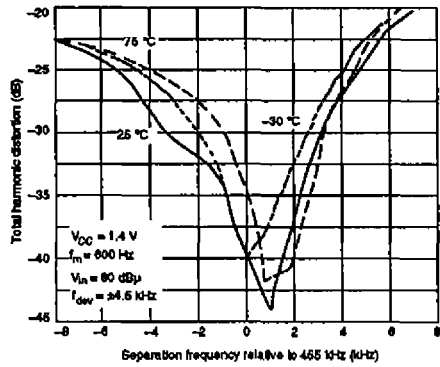

Power dissipation vs. ambient temperature

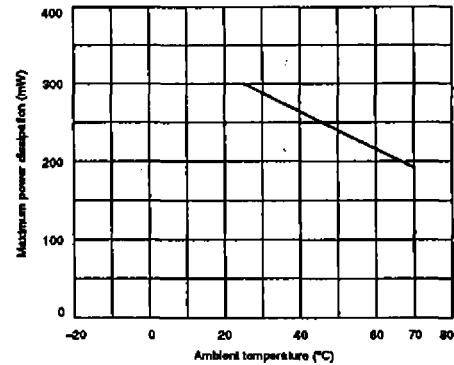

FUNCTIONAL DESCRIPTION

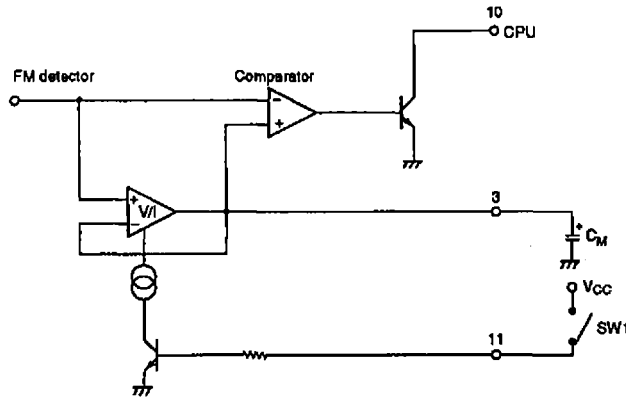

Figure 1. Wave shaper equivalent circuit

When CHGCTL goes HIGH, the voltage-to-current converter is activated, coupling the FM detector output to the detector center voltage tracking capacitor,  $C_M$ , as shown in figure 1. As  $C_M$  is connected to the noninverting input of the comparator, and the FM detector output, to the inverting input, the duty cycle of the FSK wave

shaper output signal on FSKOUT is constant. Note that the FM detector center voltage can vary as the frequency fluctuates. The wave shaper output and voltage across  $C_M$  for varying FM detector center voltage are shown in figures 2 and 3.

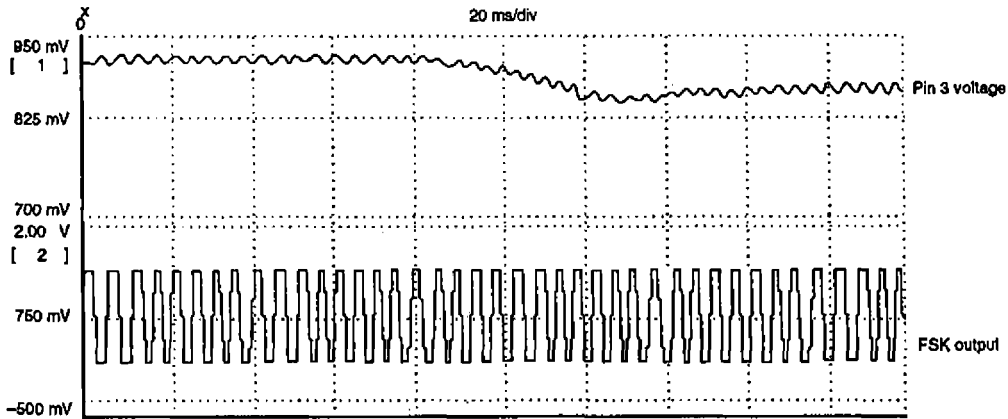

Figure 2. Wave shaper response 1

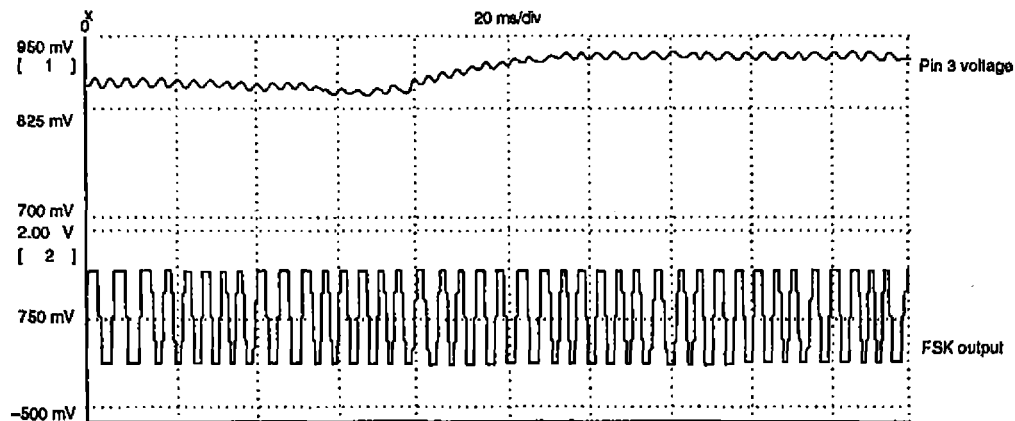

Figure 3. Wave shaper response 2



When CHGCTL goes LOW, the voltage-to-current converter is deactivated, isolating capacitor  $C_M$ . The hold voltage across  $C_M$  is then used as a threshold voltage to detect LOW-level and HIGH-level signals, for example a frame sync signal. This is called the threshold hold

function. Note that the wave shaper continues to function regardless of the level on CHGCTL. The FSK wave shaper output as  $C_M$  discharges is shown in figures 4 to 7.

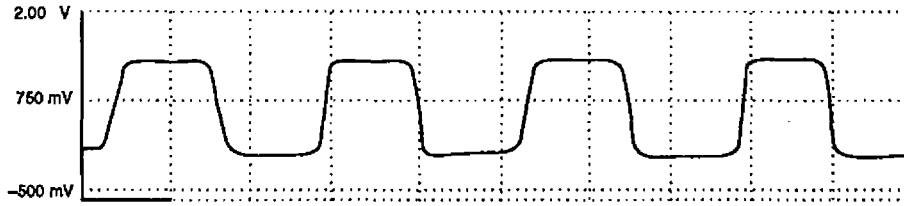

Figure 4. Wave shaper after 2 seconds

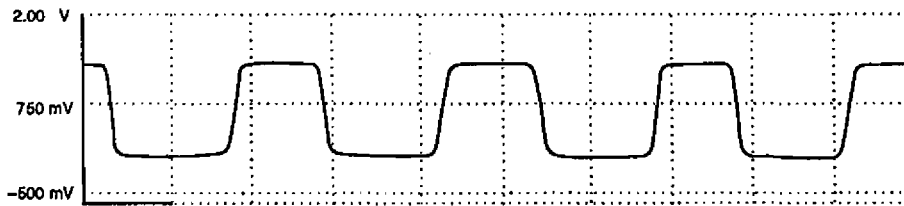

Figure 5. Wave shaper after 4 seconds

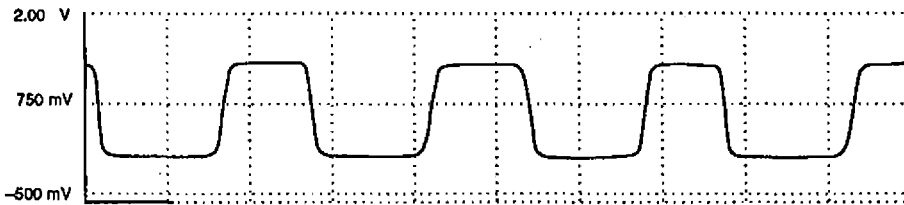

Figure 6. Wave shaper after 5 seconds

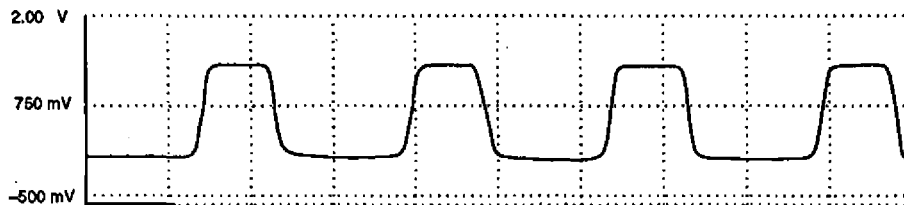

Figure 7. Wave shaper after 10 seconds

If the threshold hold function is not required, connect a 150 k $\Omega$  resistor between DC and BUFOUT as shown in figure 8.

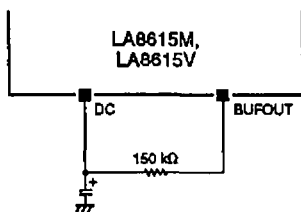
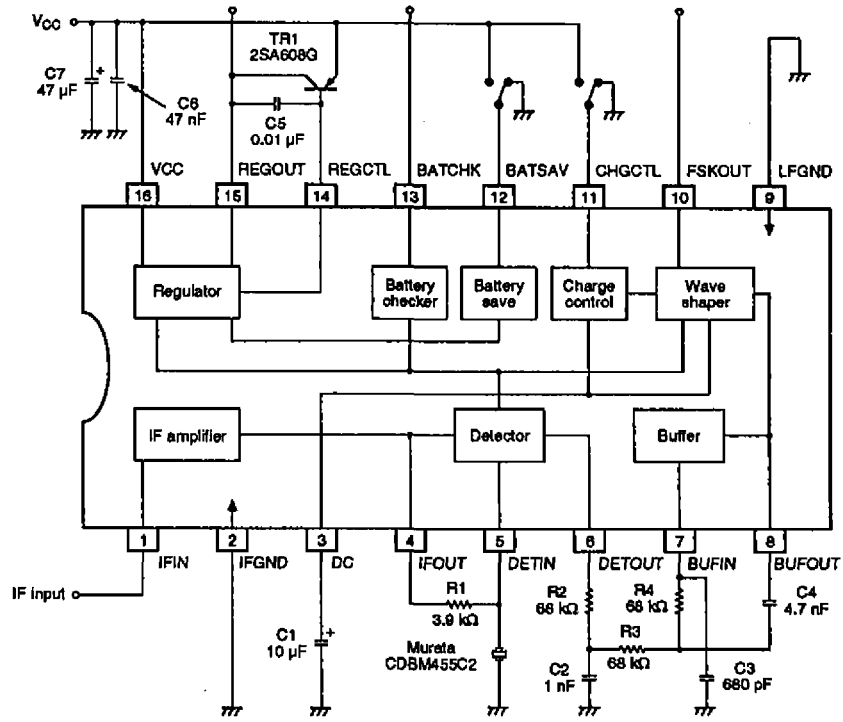
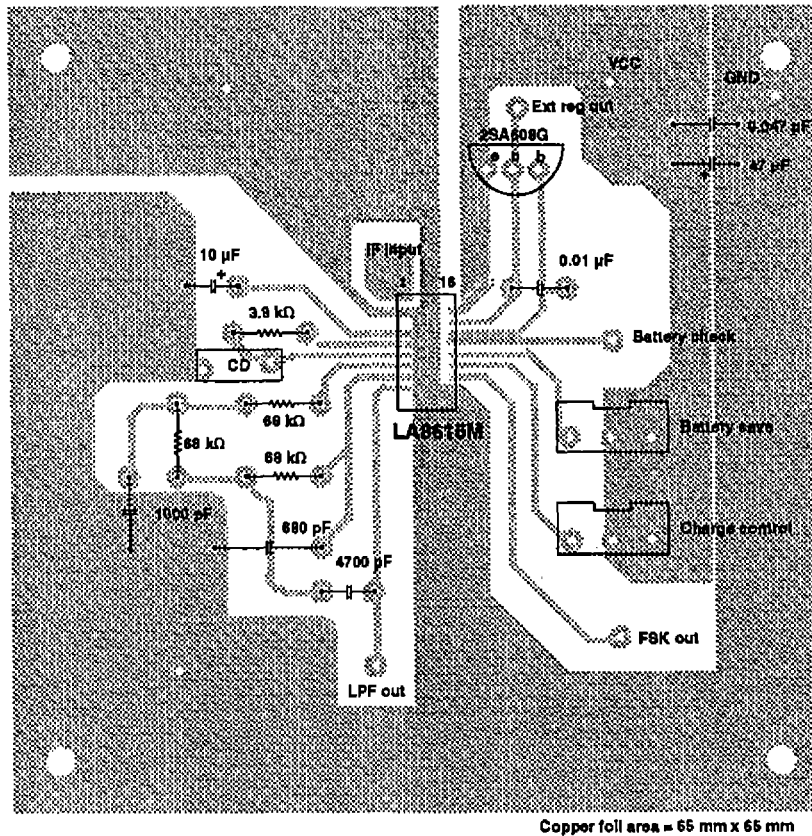

Figure 8. Connection for no threshold hold

TYPICAL APPLICATION



## LA8615M PRINTED CIRCUIT BOARD LAYOUT



- No products described or contained herein are intended for use in surgical implants, life-support systems, aerospace equipment, nuclear power control systems, vehicles, disaster/crime-prevention equipment and the like, the failure of which may directly or indirectly cause injury, death or property loss.
- Anyone purchasing any products described or contained herein for an above-mentioned use shall:
  - ① Accept full responsibility and indemnify and defend SANYO ELECTRIC CO., LTD., its affiliates, subsidiaries and distributors and all their officers and employees, jointly and severally, against any and all claims and litigation and all damages, cost and expenses associated with such use:
  - ② Not impose any responsibility for any fault or negligence which may be cited in any such claim or litigation on SANYO ELECTRIC CO., LTD., its affiliates, subsidiaries and distributors or any of their officers and employees jointly or severally.
- Information (including circuit diagrams and circuit parameters) herein is for example only; it is not guaranteed for volume production. SANYO believes information herein is accurate and reliable, but no guarantees are made or implied regarding its use or any infringements of intellectual property rights or other rights of third parties.