



SANYO Semiconductors

DATA SHEET

An ON Semiconductor Company

LC749402PT — CMOS IC Silicon gate LCD Picture Quality Improvement IC

Overview

LC749402PT is a picture quality improvement IC that processes the output signals to the LCD panel for high picture quality display. This IC performs various picture quality adjustments to provide the ideal correction for the display panel. It can support up to WVGA/SVGA panels. *

Features

(1) Digital input/output

- Digital YCbCr/YPbPr 24bit (4:4:4) or 16bit (4:2:2) or 8bit (ITU-R BT.656) signal input
- Digital RGB 24bit signal input
- Digital RGB 18bit/24bit signal output
- Digital YCbCr 16bit (4:2:2)/24bit (4:4:4) signal output

(2) Image quality correction

- Y image quality correction: luminance adjustment, contour correction, CDEX (Color Depth Expander), dynamic- γ , black/white stretch
- C image quality correction: color exciter, flesh tone correction, hue, color gain
- RGB image quality correction: brightness, contrast, white balance, black balance, γ correction

(3) Panel interface

- Built-in panel driver timing controller
- Panel protection timing signal generation
- Backlight control PWM (video adaptive low power consumption processing)

*: The LC749402PT video input should satisfy the following conditions:

40MHz or less operating frequency, 896 dots or less horizontal size, 768 lines or less vertical size.

■ Any and all SANYO Semiconductor Co.,Ltd. products described or contained herein are, with regard to "standard application", intended for the use as general electronics equipment (home appliances, AV equipment, communication device, office equipment, industrial equipment etc.). The products mentioned herein shall not be intended for use for any "special application" (medical equipment whose purpose is to sustain life, aerospace instrument, nuclear control device, burning appliances, transportation machine, traffic signal system, safety equipment etc.) that shall require extremely high level of reliability and can directly threaten human lives in case of failure or malfunction of the product or may cause harm to human bodies, nor shall they grant any guarantee thereof. If you should intend to use our products for applications outside the standard applications of our customer who is considering such use and/or outside the scope of our intended standard applications, please consult with us prior to the intended use. If there is no consultation or inquiry before the intended use, our customer shall be solely responsible for the use.

■ Specifications of any and all SANYO Semiconductor Co.,Ltd. products described or contained herein stipulate the performance, characteristics, and functions of the described products in the independent state, and are not guarantees of the performance, characteristics, and functions of the described products as mounted in the customer's products or equipment. To verify symptoms and states that cannot be evaluated in an independent device, the customer should always evaluate and test devices mounted in the customer's products or equipment.

LSI Specifications

- Supply voltage Core: 1.2V
I/O: 1.8V/2.85V/3.3V
- Maximum operating frequency: 40MHz
- Package: TQFP100

Principal Applications

- LCD display equipment

CDEX (Color Depth Expander)



Original



CDEX

Specifications

Absolute Maximum Ratings at $T_a = 25^\circ\text{C}$, $DV_{SS} = 0\text{V}$, $AV_{SS_OSC} = 0\text{V}$

Parameter	Symbol	Conditions	Ratings	Unit
Maximum supply voltage (I/O)	DV_{DD_IO}		-0.3 to +3.96	V
Maximum supply voltage (core)	DV_{DD_CORE} AV_{DD_OSC}		-0.3 to +1.8	V
Digital input voltage	V_I		-0.3 to $DV_{DD_IO}+0.3$	V
Digital output voltage	V_O		-0.3 to $DV_{DD_IO}+0.3$	V
Operating temperature	T_{opr}		-40 to +85	$^\circ\text{C}$
Storage temperature	T_{stg}		-55 to +125	$^\circ\text{C}$

Allowable Operating Ranges at $T_a = -40$ to $+85^\circ\text{C}$, $DV_{SS} = 0\text{V}$, $AV_{SS_OSC} = 0\text{V}$

Parameter	Symbol	Conditions	Ratings			unit
			min	typ	max	
Supply voltage (I/O)	DV_{DD_IO}		2.6	2.85	3.6	V
			1.7	1.8	1.9	V
Supply voltage (core)	DV_{DD_CORE} AV_{DD_OSC}		1.1	1.2	1.3	V
Input voltage range	V_{IN}		0		DV_{DD_IO}	V

LC749402PT

DC Characteristics at $T_a = -40$ to $+85^\circ\text{C}$, $DV_{SS} = 0\text{V}$, $AV_{SS_OSC} = 0\text{V}$,

$DV_{DD_IO} = 1.7\text{V}$ to 1.9V or 2.6V to 3.6V , $DV_{DD_CORE} = 1.1\text{V}$ to 1.3V

Parameter	Symbol	Conditions	Ratings			unit
			min	typ	max	
Input high-level voltage	V_{IH}	CMOS level inputs	$0.7DV_{DD_IO}$			V
		CMOS level schmitt inputs	$0.7DV_{DD_IO}$			V
Input low-level voltage	V_{IL}	CMOS level inputs			$0.3DV_{DD_IO}$	V
		CMOS level schmitt inputs			$0.3DV_{DD_IO}$	V
Input high-level current	I_{IH}	$V_I = DV_{DD_IO}$			10	μA
		$V_I = DV_{DD_IO}$, with pull-down resistance			100	μA
Input low-level current	I_{IL}	$V_I = DV_{SS}$	-10			μA
Output high-level voltage	V_{OH}	CMOS voltage: 2.6V to 3.6V Pin D: $I_{OH} = -2\text{mA}$ Pin F: $I_{OH} = -2\text{mA}$ (when set to 2mA) $I_{OH} = -4\text{mA}$ (when set to 4mA) Pin G: $I_{OH} = -4\text{mA}$ (when set to 4mA) $I_{OH} = -8\text{mA}$ (when set to 8mA) Pin H: $I_{OH} = -4\text{mA}$	$DV_{DD_IO} - 0.4$			V
		CMOS voltage: 1.7V to 1.9V Pin D: $I_{OH} = -1\text{mA}$ Pin F: $I_{OH} = -1\text{mA}$ (when set to 2mA) $I_{OH} = -2\text{mA}$ (when set to 4mA) Pin G: $I_{OH} = -2\text{mA}$ (when set to 4mA) $I_{OH} = -4\text{mA}$ (when set to 8mA) Pin H: $I_{OH} = -2\text{mA}$	$DV_{DD_IO} - 0.45$			V
Output low-level voltage	V_{OL}	CMOS			0.4	V
Output leak current	I_{OZ}	At output of high-impedance	-10		10	μA
Pull-down resistor	R_{DN}	Typical conditions: $T_a = 25^\circ\text{C}$ $DV_{DD_IO} = 2.85\text{V}$ $DV_{DD_CORE} = 1.2\text{V}$		98		k Ω
Dynamic supply current	I_{DDOP}	Typical conditions: $T_a = 25^\circ\text{C}$ $DV_{DD_IO} = 2.85\text{V}$ $DV_{DD_CORE} = 1.2\text{V}$ tck=10MHz 10 steps		18		mA
		Typical conditions: $T_a = 25^\circ\text{C}$ $DV_{DD_IO} = 2.85\text{V}$ $DV_{DD_CORE} = 1.2\text{V}$ tck=40MHz 10 steps		57		mA
Static supply current *1	I_{DDST}	Typical conditions: $T_a = 25^\circ\text{C}$ $DV_{DD_IO} = 2.85\text{V}$ $DV_{DD_CORE} = 1.2\text{V}$ Outputs open $V_I = DV_{SS}$ or DV_{DD_IO}		20		μA

*1: There is a input terminal which builds in pull down resistance. Please note that there is no guarantee about static consumption current depending on circuit composition.

LC749402PT

Package Dimensions

unit:mm (typ)

3274

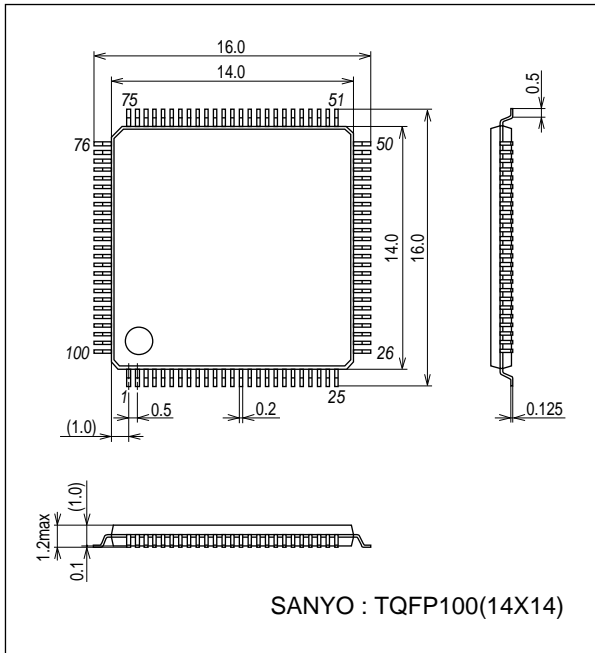

Pin Assignment

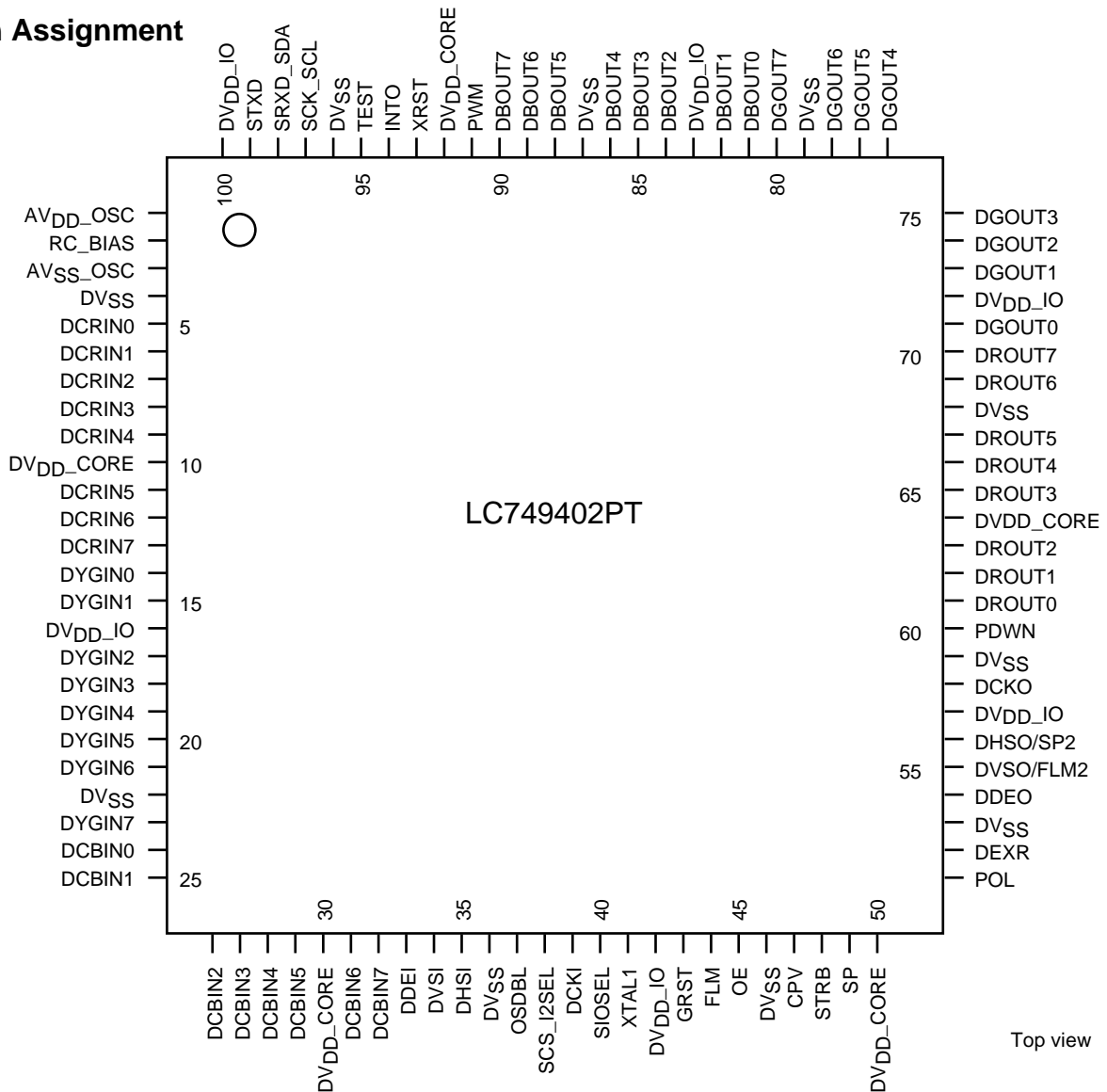

Top view

LC749402PT

Block Diagram

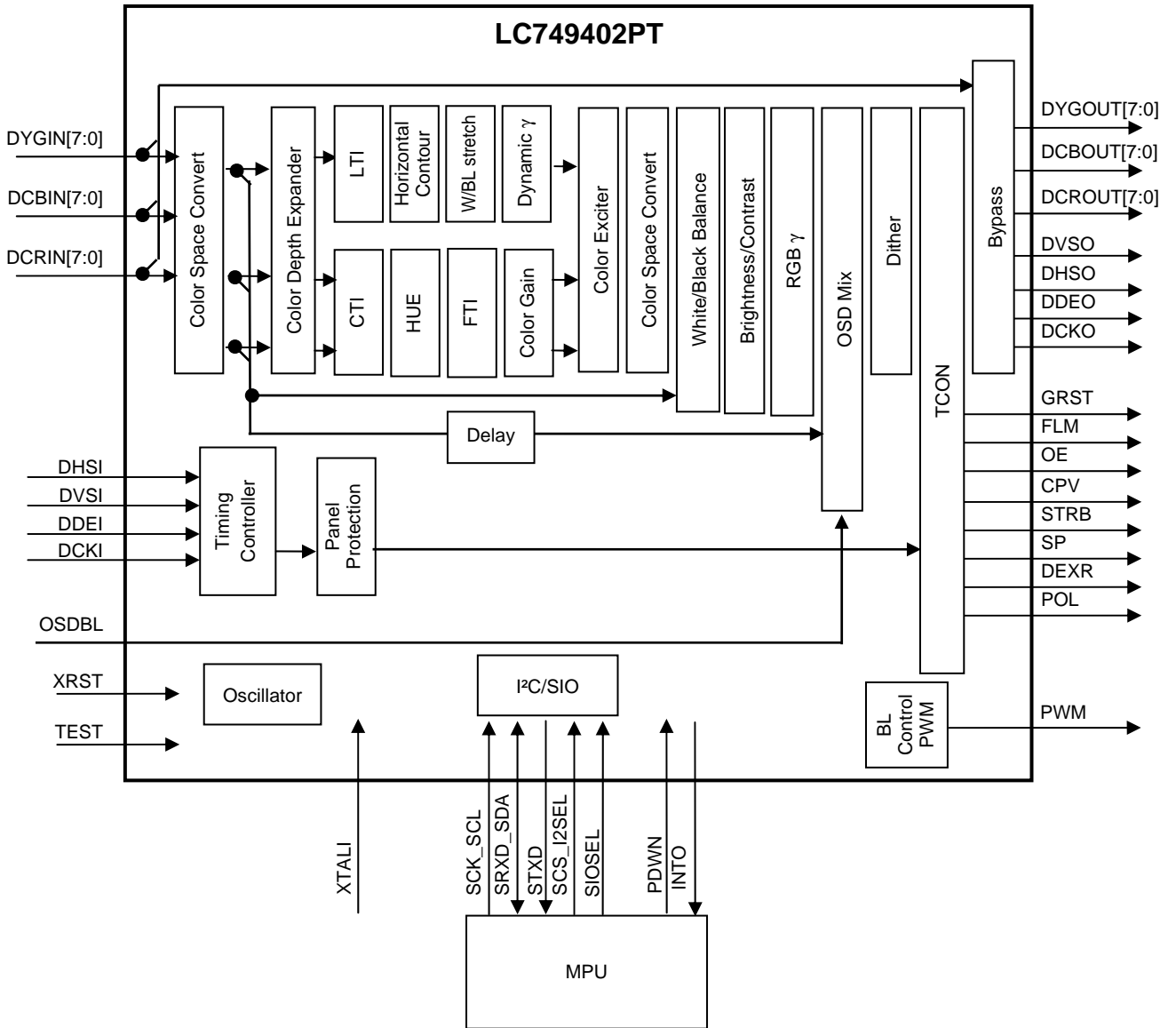

LC749402PT

Pin Functions

Pin No.	Pin symbol	In/output format		Connecting destination		Remarks
		I/O	Format			
1	AV _{DD} _OSC	P	-	Core Voltage	Analog	
2	RC_BIAS	I	J	Resistor	Analog	Bias resistor connection (Connect to ground through 20kΩ resistor)
3	AV _{SS} _OSC	P	-	GND	Analog	
4	DV _{SS}	P	-	GND	Digital	
5	DCRIN0	I	C	CMOS	Digital	R/Cr video input. (LSB Connect to GND when not used.)
6	DCRIN1	I	C	CMOS	Digital	R/Cr video input. (Connect to GND when not used.)
7	DCRIN2	I	C	CMOS	Digital	R/Cr video input (Connect to GND when not used.)
8	DCRIN3	I	C	CMOS	Digital	R/Cr video input (Connect to GND when not used.)
9	DCRIN4	I	C	CMOS	Digital	R/Cr video input (Connect to GND when not used.)
10	DV _{DD} _CORE	P	-	Core Voltage	Digital	
11	DCRIN5	I	C	CMOS	Digital	R/Cr video input (Connect to GND when not used.)
12	DCRIN6	I	C	CMOS	Digital	R/Cr video input (Connect to GND when not used.)
13	DCRIN7	I	C	CMOS	Digital	R/Cr video input (MSB Connect to GND when not used.)
14	DYGIN0	I	C	CMOS	Digital	G/Y/656 video input (LSB Connect to GND when not used.)
15	DYGIN1	I	C	CMOS	Digital	G/Y/656 video input (Connect to GND when not used.)
16	DV _{DD} _IO	P	-	IO voltage	Digital	
17	DYGIN2	I	C	CMOS	Digital	G/Y/656 video input (Connect to GND when not used.)
18	DYGIN3	I	C	CMOS	Digital	G/Y/656 video input (Connect to GND when not used.)
19	DYGIN4	I	C	CMOS	Digital	G/Y/656 video input (Connect to GND when not used.)
20	DYGIN5	I	C	CMOS	Digital	G/Y/656 video input (Connect to GND when not used.)
21	DYGIN6	I	C	CMOS	Digital	G/Y/656 video input (Connect to GND when not used.)
22	DV _{SS}	P	-	GND	Digital	
23	DYGIN7	I	C	CMOS	Digital	G/Y/656 video input (MSB Connect to GND when not used.)
24	DCBIN0	I	C	CMOS	Digital	B/Cb/C video (LSB Connect to GND when not used.)
25	DCBIN1	I	C	CMOS	Digital	B/Cb/C video input (Connect to GND when not used.)
26	DCBIN2	I	C	CMOS	Digital	B/Cb/C video input (Connect to GND when not used.)
27	DCBIN3	I	C	CMOS	Digital	B/Cb/C video input (Connect to GND when not used.)
28	DCBIN4	I	C	CMOS	Digital	B/Cb/C video input (Connect to GND when not used.)
29	DCBIN5	I	C	CMOS	Digital	B/Cb/C video input (Connect to GND when not used.)
30	DV _{DD} _CORE	P	-	Core Voltage	Digital	
31	DCBIN6	I	C	CMOS	Digital	B/Cb/C video input (Connect to GND when not used.)
32	DCBIN7	I	C	CMOS	Digital	B/Cb/C video input (MSB Connect to GND when not used.)
33	DDEI	I	C	CMOS	Digital	Data enable signal. (Connect to GND when not used.)
34	DVSI	I	C	CMOS	Digital	Vertical sync signal
35	DHSI	I	C	CMOS	Digital	Horizontal sync signal.
36	DV _{SS}	P	-	GND	Digital	
37	OSDBL	I	C	CMOS	Digital	Data enable signal for external OSD. (Connect to GND when not used.)
38	SCS_I2SEL	I	A	CMOS	Digital	SIO chip enable / I ² C slave select
39	DCKI	I	C	CMOS	Digital	Video clock.
40	SIOSEL	I	C	CMOS	Digital	"L": I ² C slave, "H": 4 wire SIO
41	XTAL1	I	C	CMOS	Digital	External clock input for panel protection. (Connect to GND when not used.)
42	DV _{DD} _IO	P	-	IO voltage	Digital	
43	GRST	O	F	CMOS	Digital	Gate driver reset signal.
44	FLM	O	F	CMOS	Digital	Start pulse signal for gate driver
45	OE	O	F	CMOS	Digital	Output enable signal for gate driver.
46	DV _{SS}	P	-	GND	Digital	
47	CPV	O	F	CMOS	Digital	Gate driver clock signal.
48	STRB	O	F	CMOS	Digital	Data strobe signal for source driver.
49	SP	O	F	CMOS	Digital	Start pulse signal for source driver.

Continued on next page.

LC749402PT

Continued from preceding page.

Pin No.	Pin symbol	In/output format		Connecting destination		Remarks
		I/O	Format			
50	DV _{DD} _CORE	P	-	Core Voltage	Digital	
51	POL	O	F	CMOS	Digital	Voltage polarity selection signal for the source driver.
52	DEXR	O	F	CMOS	Digital	Reversed video signal output for DTR. Low output when the DTR is OFF.
53	DV _{SS}	P	-	GND	Digital	
54	DDEO	O	F	CMOS	Digital	Data enable signal
55	DVSO / FLM2	O	F	CMOS	Digital	Vertical sync signal / Start pulse signal for gate driver
56	DHSO / SP2	O	F	CMOS	Digital	Horizontal sync signal / Start pulse signal for source driver
57	DV _{DD} _IO	P	-	IO voltage	Digital	
58	DCKO	O	G	CMOS	Digital	Video clock output
59	DV _{SS}	P	-	GND	Digital	
60	PDWN	I	A	CMOS	Digital	"H" power down control (Connect to GND when not used.)
61	DROUT0	O	F	CMOS	Digital	R/Cr video output (LSB when 8-bit output is selected)
62	DROUT1	O	F	CMOS	Digital	R/Cr video output
63	DROUT2	O	F	CMOS	Digital	R/Cr video output (LSB when 6-bit output is selected)
64	DV _{DD} _CORE	P	-	Core Voltage	Digital	
65	DROUT3	O	F	CMOS	Digital	R/Cr video output
66	DROUT4	O	F	CMOS	Digital	R/Cr video output
67	DROUT5	O	F	CMOS	Digital	R/Cr video output
68	DV _{SS}	P	-	GND	Digital	
69	DROUT6	O	F	CMOS	Digital	R/Cr video output
70	DROUT7	O	F	CMOS	Digital	R/Cr video output (MSB)
71	DGOUT0	O	F	CMOS	Digital	G/Y video output (LSB when 8-bit output is selected)
72	DV _{DD} _IO	P	-	IO voltage	Digital	
73	DGOUT1	O	F	CMOS	Digital	G/Y video output
74	DGOUT2	O	F	CMOS	Digital	G/Y video output (LSB when 6-bit output is selected)
75	DGOUT3	O	F	CMOS	Digital	G/Y video output
76	DGOUT4	O	F	CMOS	Digital	G/Y video output
77	DGOUT5	O	F	CMOS	Digital	G/Y video output
78	DGOUT6	O	F	CMOS	Digital	G/Y video output
79	DV _{SS}	P	-	GND	Digital	
80	DGOUT7	O	F	CMOS	Digital	G/Y video output (MSB)
81	DBOUT0	O	F	CMOS	Digital	B/Cb/C video output (LSB when 8-bit output is selected)
82	DBOUT1	O	F	CMOS	Digital	B/Cb/C video output
83	DV _{DD} _IO	P	-	IO voltage	Digital	
84	DBOUT2	O	F	CMOS	Digital	B/Cb/C video output (LSB when 6-bit output is selected)
85	DBOUT3	O	F	CMOS	Digital	B/Cb/C video output
86	DBOUT4	O	F	CMOS	Digital	B/Cb/C video output
87	DV _{SS}	P	-	GND	Digital	
88	DBOUT5	O	F	CMOS	Digital	B/Cb/C video output
89	DBOUT6	O	F	CMOS	Digital	B/Cb/C video output
90	DBOUT7	O	F	CMOS	Digital	B/Cb/C video output (MSB)
91	PWM	O	D	CMOS	Digital	Pulse width modulation waveform output
92	DV _{DD} _CORE	P	-	Core Voltage	Digital	
93	XRST	I	A	CMOS	Digital	System reset ("L" reset)
94	INTO	O	D	CMOS	Digital	Interrupt
95	TEST	I	B	CMOS	Digital	Test setting (Connect to GND normally)
96	DV _{SS}	P	-	GND	Digital	
97	SCK_SCL	I	C	CMOS	Digital	Bus clock (shared with SIO/I ² C)
98	SRXD_SDA	I/O	H	CMOS	Digital	SIO data input / I ² C data input/output
99	STXD	O	D	CMOS	Digital	SIO data
100	DV _{DD} _IO	P	-	IO voltage	Digital	

LC749402PT

Pin Type

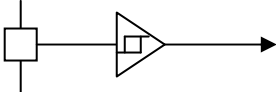
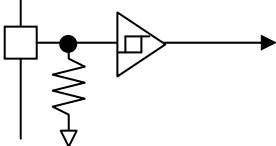
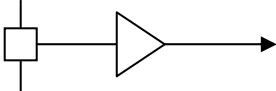
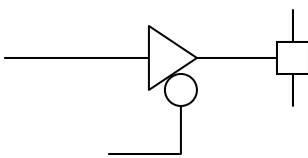
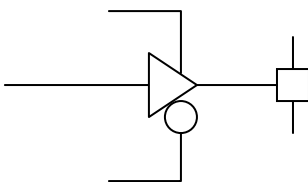
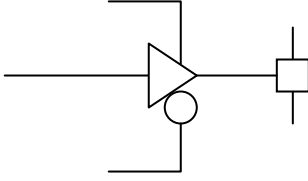
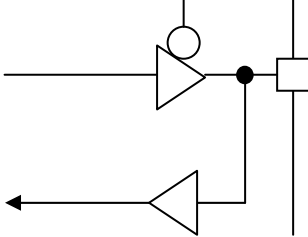
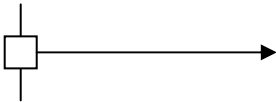
In/Output form	Function	Equivalent circuit	Application Terminal
A	Schmitt trigger CMOS input		XRST, PDWN, SCS_I2SEL
B	CMOS input with built-in pull-down resistor		TEST
C	CMOS input		SCK_SCL, SIOSEL, DVSI, DHSI, DDEI, OSDBL, DYGIN7, DYGIN6, DYGIN5, DYGIN4, DYGIN3, DYGIN2, DYGIN1, DYGIN0, DCBIN7, DCBIN6, DCBIN5, DCBIN4, DCBIN3, DCBIN2, DCBIN1, DCBIN0, DCRIN7, DCRIN6, DCRIN5, DCRIN4, DCRIN3, DCRIN2, DCRIN1, DCRIN0
D	2mA 3-STATE drive CMOS output		STXD, PWM, INTO
F	2mA/4mA switching 3-STATE drive CMOS output		DBOUT7, DBOUT6, DBOUT5, DBOUT4, DBOUT3, DBOUT2, DBOUT1, DBOUT0, DROUT7, DROUT6, DROUT5, DROUT4, DROUT3, DROUT2, DROUT1, DROUT0 DGOUT7, DGOUT6, DGOUT5, DGOUT4, DGOUT3, DGOUT2, DGOUT1, DGOUT0, DHSO/SP2, DVSO/FLM2, DDEO FLM, DEXR, POL, GRST, CPV, SP, OE, STRB
G	4mA/8mA switching 3-STATE drive CMOS output		DCKO
H	4mA 3-STATE drive CMOS input/output		SRXD_SDA
J	Analog input/output		RC_BIAS

LC749402PT

I/O Timing

(1) Input data timing

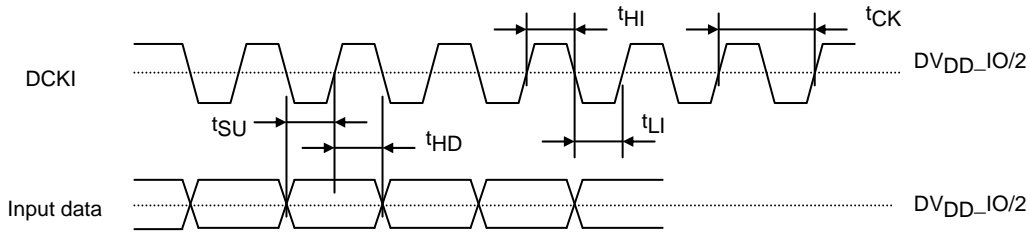

Pin name	Parameter	Symbol	min	typ	max	unit
DCKI	Clock cycle	tCK	25			ns
	Duty			50		%
DCRIN*, DYGIN*, DCBIN*, DVSI, DHSI, DDEI, OSDBL	Input data setup time (DVDD_IO=2.6 to 3.6V)	tSU	3			ns
	Input data setup time (DVDD_IO=1.7 to 1.9V)	tSU	3			ns
	Input data hold time (DVDD_IO=2.6 to 3.6V)	tHD	2			ns
	Input data hold time (DVDD_IO=1.7 to 1.9V)	tHD	2			ns

*: The recommended duty cycle of input clock is 50%

(2) Output data timing

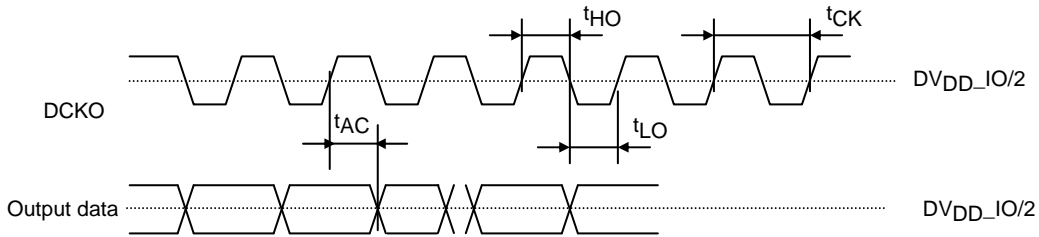

Pin name	Parameter	Symbol	min	typ	max	unit
DCKO	Clock cycle	tCK	25			ns
	Duty			50		%
DROUT*, DGOUT*, DBOUT*, DVSO, DHSO, DDEO, DEXR, POL, SP, STRB, CPV, OE, FLM, GRST	Output data delay time (DVDD_IO=2.6 to 3.6V) Pin F: when set to 4mA Pin G: when set to 8mA	tAC	-3		3	ns
	Output data delay time (DVDD_IO=2.6 to 3.6V) Pin F: when set to 2mA Pin G: when set to 4mA	tAC	-3		6	ns
	Output data delay time (DVDD_IO=1.7 to 1.9V) Pin F: when set to 4mA Pin G: when set to 8mA	tAC	-5		4	ns
	Output data delay time (DVDD_IO=1.7 to 1.9V) Pin F: when set to 2mA Pin G: when set to 4mA	tAC	-6		9	ns

* When DCKO is set to the forward rotation output. Output load capacity: 5pF

- SANYO Semiconductor Co.,Ltd. assumes no responsibility for equipment failures that result from using products at values that exceed, even momentarily, rated values (such as maximum ratings, operating condition ranges, or other parameters) listed in products specifications of any and all SANYO Semiconductor Co.,Ltd. products described or contained herein.
- SANYO Semiconductor Co.,Ltd. strives to supply high-quality high-reliability products, however, any and all semiconductor products fail or malfunction with some probability. It is possible that these probabilistic failures or malfunction could give rise to accidents or events that could endanger human lives, trouble that could give rise to smoke or fire, or accidents that could cause damage to other property. When designing equipment, adopt safety measures so that these kinds of accidents or events cannot occur. Such measures include but are not limited to protective circuits and error prevention circuits for safe design, redundant design, and structural design.
- In the event that any or all SANYO Semiconductor Co.,Ltd. products described or contained herein are controlled under any of applicable local export control laws and regulations, such products may require the export license from the authorities concerned in accordance with the above law.
- No part of this publication may be reproduced or transmitted in any form or by any means, electronic or mechanical, including photocopying and recording, or any information storage or retrieval system, or otherwise, without the prior written consent of SANYO Semiconductor Co.,Ltd.
- Any and all information described or contained herein are subject to change without notice due to product/technology improvement, etc. When designing equipment, refer to the "Delivery Specification" for the SANYO Semiconductor Co.,Ltd. product that you intend to use.
- Information (including circuit diagrams and circuit parameters) herein is for example only; it is not guaranteed for volume production.
- Upon using the technical information or products described herein, neither warranty nor license shall be granted with regard to intellectual property rights or any other rights of SANYO Semiconductor Co.,Ltd. or any third party. SANYO Semiconductor Co.,Ltd. shall not be liable for any claim or suits with regard to a third party's intellectual property rights which has resulted from the use of the technical information and products mentioned above.

This catalog provides information as of December, 2010. Specifications and information herein are subject to change without notice.