



LC75821E, 75821W

LCD Display Drivers

Overview

The LC75821E and LC75821W are general-purpose LCD display drivers that can be used for frequency display in microprocessor-controlled radio receivers and in other display applications.

Features

- 53 segment outputs (the maximum for static drive)
- Two drive types: static (1/1) duty (53 segments) and 1/2 duty (104 segments)
- Data input: 3 serial input pins
- INH pin for turning off all display output
- The difference from the LC7582: The LC75821E, LC75821W are A/D converter, DSP function-removed versions of the LC7582 of which the functions other than the two can be used with pin compatibility with the LC7582 kept.

Package Dimensions

unit: mm

3159-QFP64E

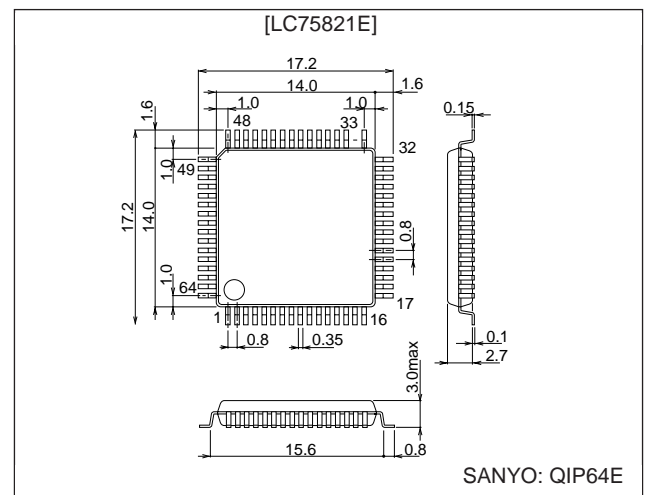

unit: mm

3190-SQFP64

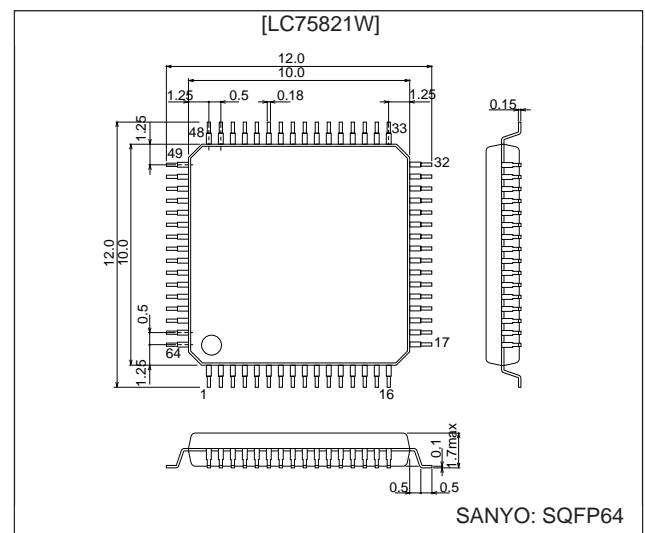

Specifications

Absolute Maximum Ratings at $T_a = 25^\circ\text{C}$, $V_{SS} = 0\text{ V}$

Parameter	Symbol	Conditions	Ratings	Unit
Maximum supply voltage	$V_{DD\text{ max}}$	V_{DD}	-0.3 to +7.0	V
	V_{LCD}	V_{LCD}	-0.3 to $V_{DD} + 0.3$	V
Input voltage	V_{IN1}	CE, CLK, DATA, \overline{INH}	-0.3 to +7.0	V
	V_{IN2}	OSC: output off	-0.3 to $V_{DD} + 0.3$	V
Output voltage	V_{OUT}	OSC: output off	-0.3 to $V_{DD} + 0.3$	V
Output current	I_{OUT1}	S1 to S53	100	μA
	I_{OUT2}	COM1, COM2	1.0	mA
Allowable power dissipation	$P_{d\text{ max}}$	$T_a = 85^\circ\text{C}$	100	mW
Operating temperature	T_{opr}		-40 to +85	$^\circ\text{C}$
Storage temperature	T_{stg}		-55 to +125	$^\circ\text{C}$

Allowable Operating Ranges at $T_a = -40$ to $+85^\circ\text{C}$, $V_{SS} = 0\text{ V}$

Parameter	Symbol	Conditions	min	typ	max	Unit
Supply voltage	V_{DD}	V_{DD}	3.0		6.5	V
	V_{LCD}	V_{LCD}	3.0		V_{DD}	V
Input high-level voltage	V_{IH1}	\overline{INH}	0.7 V_{DD}		6.5	V
Input high-level voltage	V_{IH2}	CE, CLK, DATA	0.8 V_{DD}		6.5	V
Input low-level voltage	V_{IL1}	\overline{INH}	0		0.3 V_{DD}	V
Input low-level voltage	V_{IL2}	CE, CLK, DATA	0		0.2 V_{DD}	V
Recommended external resistance	R_{OSC}	OSC		51		$\text{k}\Omega$
Recommended external capacitance	C_{OSC}	OSC		680		pF
Guaranteed oscillation range	f_{OSC}	OSC	25	50	100	kHz
Clock low-level pulse width	$t_{\phi L}$	CLK	0.25			μs
Clock high-level pulse width	$t_{\phi H}$	CLK	0.25			μs
Data setup time	t_{sup}	CLK, DATA	0.25			μs
Data hold time	t_{dh}	CLK, DATA	0.25			μs
Serial data pulse width	t_1	CE, DATA	1			μs
	t_2	CE, CLK	1.25			μs
	t_3				1	μs
	t_4		4			μs

Electrical Characteristics for the Allowable Operating Ranges

Parameter	Symbol	Conditions	min	typ	max	Unit
Input high-level current	I_{IH}	CE, CLK, DATA, \overline{INH} : $V_I = 6.5\text{ V}$			5	μA
Input low-level current	I_{IL}	CE, CLK, DATA, \overline{INH} : $V_I = 0\text{ V}$	-5			μA
Output high-level voltage	V_{OH1}	S1 to S53: $I_O = -10\ \mu\text{A}$	$V_{DD} - 1.0$			V
Output high-level voltage	V_{OH2}	COM1, COM2: $I_O = -100\ \mu\text{A}$	$V_{LCD} - 0.6$			V
Output low-level voltage	V_{OL1}	S1 to S53: $I_O = 10\ \mu\text{A}$			1.0	V
Output low-level voltage	V_{OL2}	COM1, COM2: $I_O = 100\ \mu\text{A}$			0.6	V
Mid-level voltage	V_{MID1}	COM1, COM2: $V_{LCD} = 6.5\text{ V}$, $I_O = \pm 100\ \mu\text{A}$	2.65	3.25	3.85	V
	V_{MID2}	COM1, COM2: $V_{LCD} = 3.0\text{ V}$, $I_O = \pm 100\ \mu\text{A}$	0.9	1.5	2.1	V
Oscillator frequency	f_{OSC}	OSC: $R = 51\ \text{k}\Omega$, $C = 680\ \text{pF}$	40	50	60	kHz
Hysteresis voltage	V_H	CE, CLK, DATA: $V_{DD} = 5\text{ V}$	0.3			V
Current drain	I_{DD}				0.6	mA
	I_{LCD}	V_{LCD}			2	mA

LC75821E, 75821W

Pin Assignment

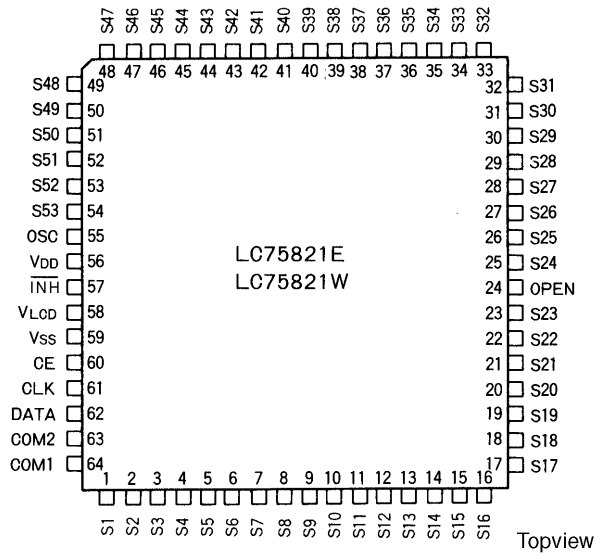

Block Diagram

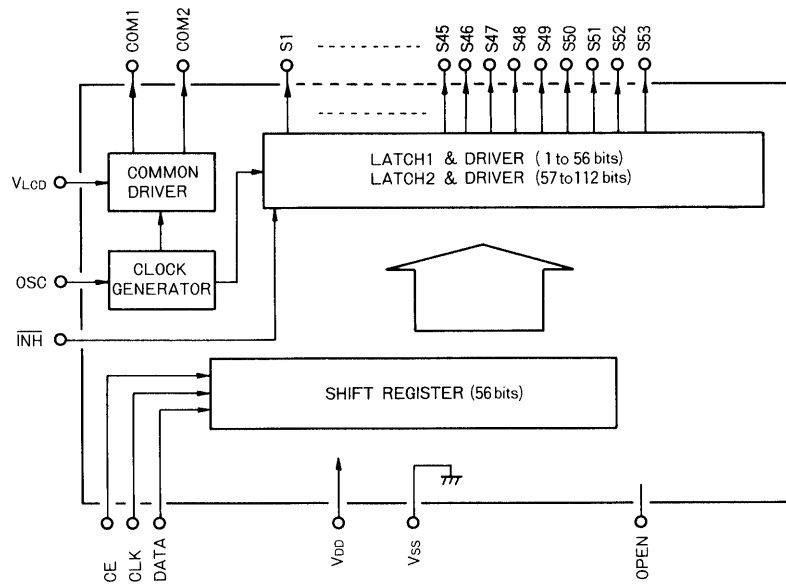

Pin Functions

Pin	Function
S1 to S53	Segment output pins
COM1, COM2	Common output pins (Only COM1 is used in static (1/1) drive. COM2 must be left open in that mode.)
V_{LCD}	LCD bias voltage setting
OSC	Oscillator connection
CE, CLK, DATA	Serial data transfer inputs
V_{SS} , V_{DD}	Power supply
\overline{INH}	Display off control input \overline{INH} = low (V_{SS})Display off (S1 to S53, COM1, COM2 = low) \overline{INH} = high (V_{DD}).....Display on Note that serial data transfers can be performed when display output is forced off.
OPEN	Make no connections to this pin.

Data Transfer Format

1. Static (1/1) duty

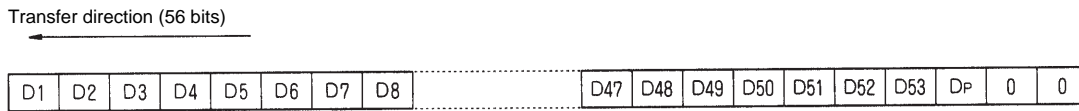

2. 1/2 duty (Only 56 bits need to be transferred if there are no more than 52 display segments. The transfer format is identical to the static duty case. It is not possible to change the D54 to D106 data without specifying the D1 to D53 data.)

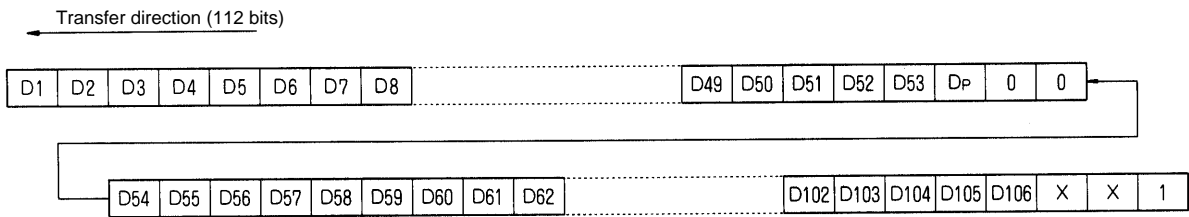

The values of bits D53 and D106 are ignored.(don't care)

- D1 to D53: Display data (1/1 duty) Lighted at 1
- D1 to D106: Display data (1/2 duty) Unlighted at 0
- DP: Drive type selection bit
 - 1/2 duty at 1
 - 1/1 duty at 0
- x: don't care

Data Transfer Examples

1. Static duty

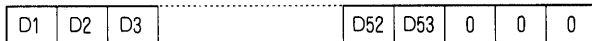

2. 1/2 duty with 52 or fewer segments

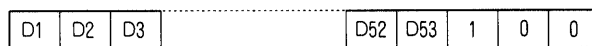

3. 1/2 duty with more than 52 segments

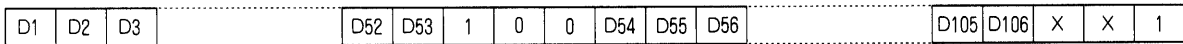

Note: The following transfer format is not allowed in 1/2 duty with 52 or fewer segments.

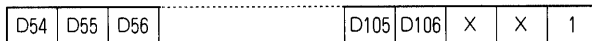

Serial Data

1. Static duty (56 bits)

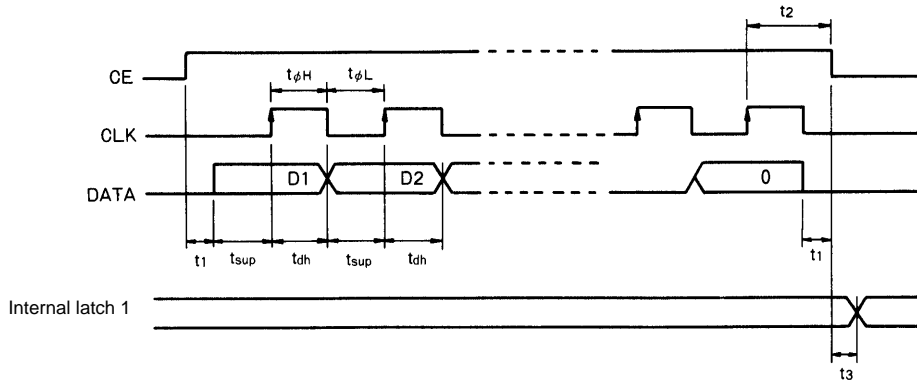

2. 1/2 duty (112 bits)

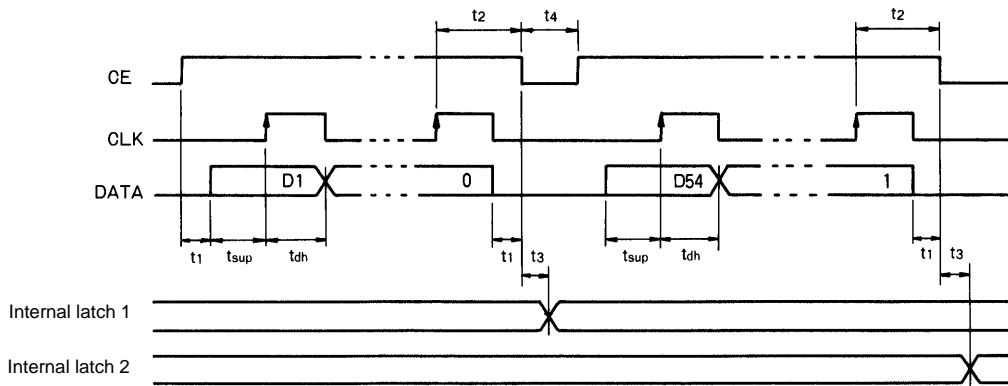

Output Waveforms

1. Static duty

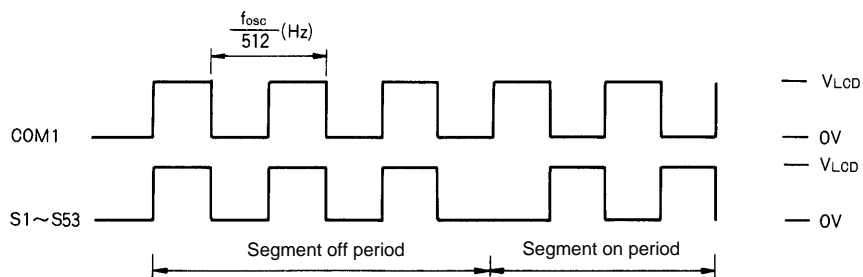

2. 1/2 duty

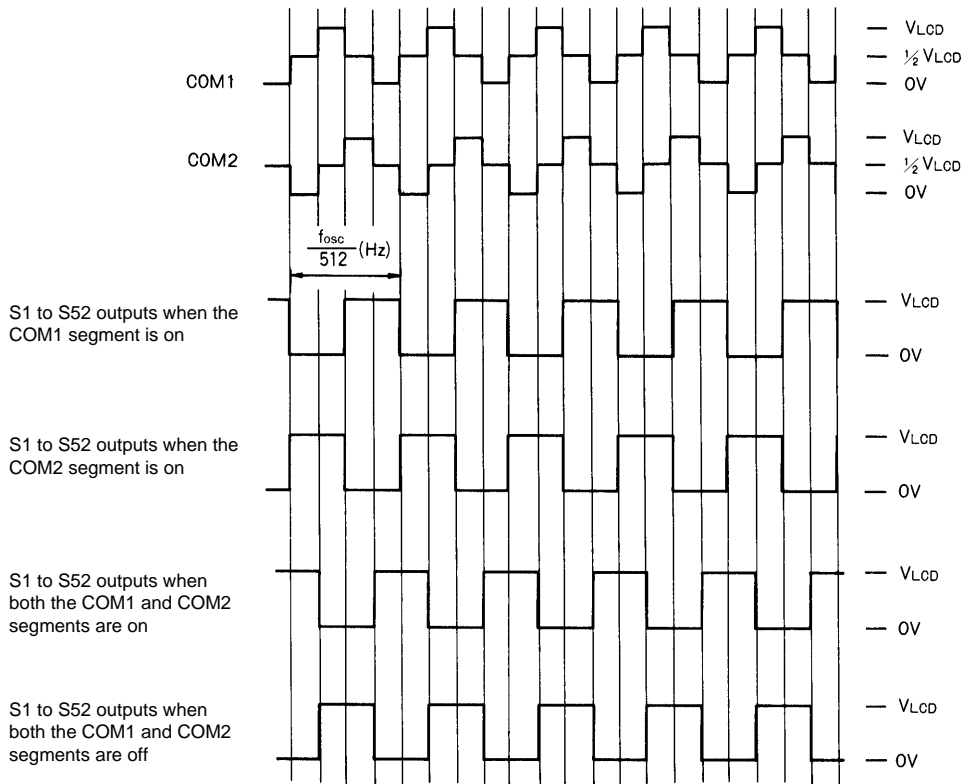

Display Examples

1. Static drive (1/1 duty)

Example with 40 segments (Up to 53 segments can be driven.)

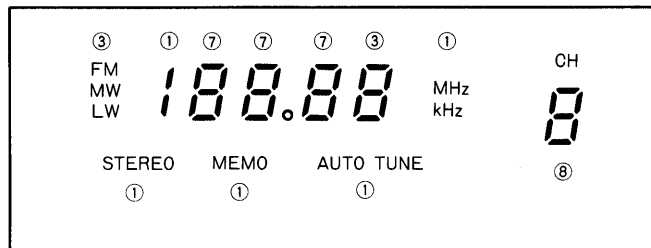

Note: Numbers in circles indicate the number of segments used.

2. 1/2 duty drive

Example with 80 segments (Up to 104 segments can be driven.)

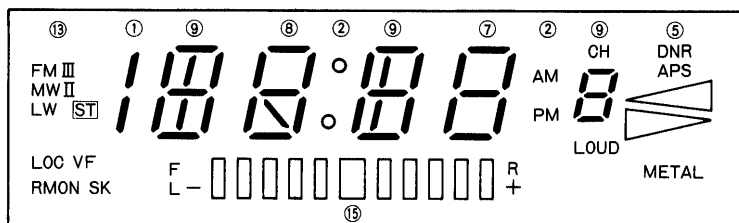

Sample Application Circuit 1

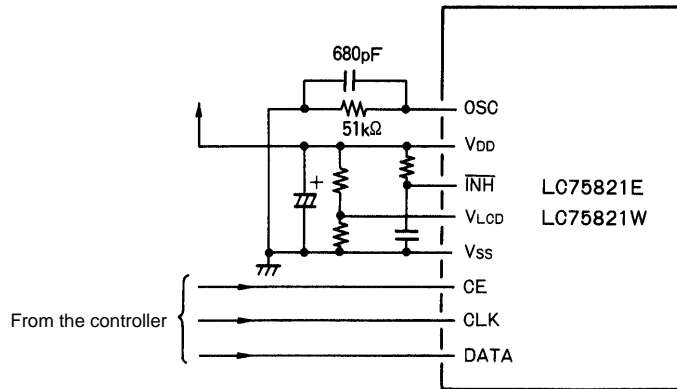

Sample Application Circuit 2

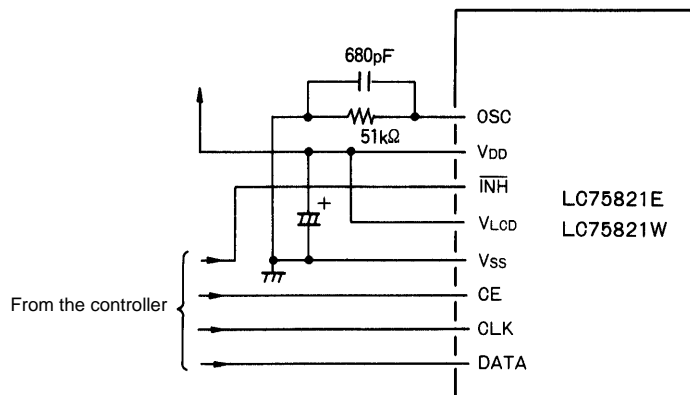

Note: The internal display data is undefined when power (V_{DD}) is first applied. Since a meaningless pattern will be displayed if the display is turned on in that state, the display should be turned off by setting INH low and turned on only after display data has been sent from the controller.

LC75821E, 75821W

Transfer (external input) Data/Output Pin Correspondence

Output pin \ DP	0	1	COM1	COM2
	1/1 duty	1/2 duty		
S1	D1	D1	○	
		D2		○
S2	D2	D3	○	
		D4		○
S3	D3	D5	○	
		D6		○
⋮	⋮	⋮	⋮	⋮
S26	D26	D51	○	
		D52		○
S27	D27	D54	○	
		D55		○
S28	D28	D56	○	
		D57		○
⋮	⋮	⋮	⋮	⋮
S43	D43	D86	○	
		D87		○
S44	D44	D88	○	
		D89		○
S45	D45	D90	○	
		D91		○
S46	D46	D92	○	
		D93		○
S47	D47	D94	○	
		D95		○
S48	D48	D96	○	
		D97		○
S49	D49	D98	○	
		D99		○
S50	D50	D100	○	
		D101		○
S51	D51	D102	○	
		D103		○
S52	D52	D104	○	
		D105		○
S53	D53	Always on	○	
		Always on		○

Note: Only COM1 is used in static (1/1 duty) drive.

Oscillator Frequency

Refer to the figure below when determining the oscillator frequency.

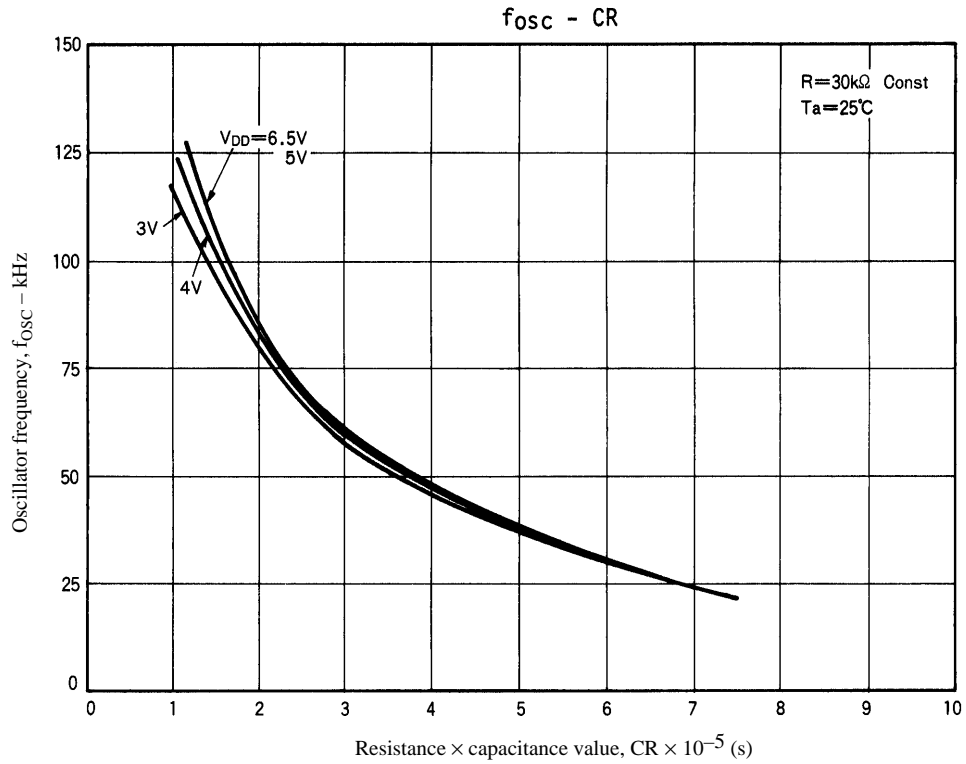

Figure 1 LC75821E, 75821W Oscillator Frequency vs. CR Constant

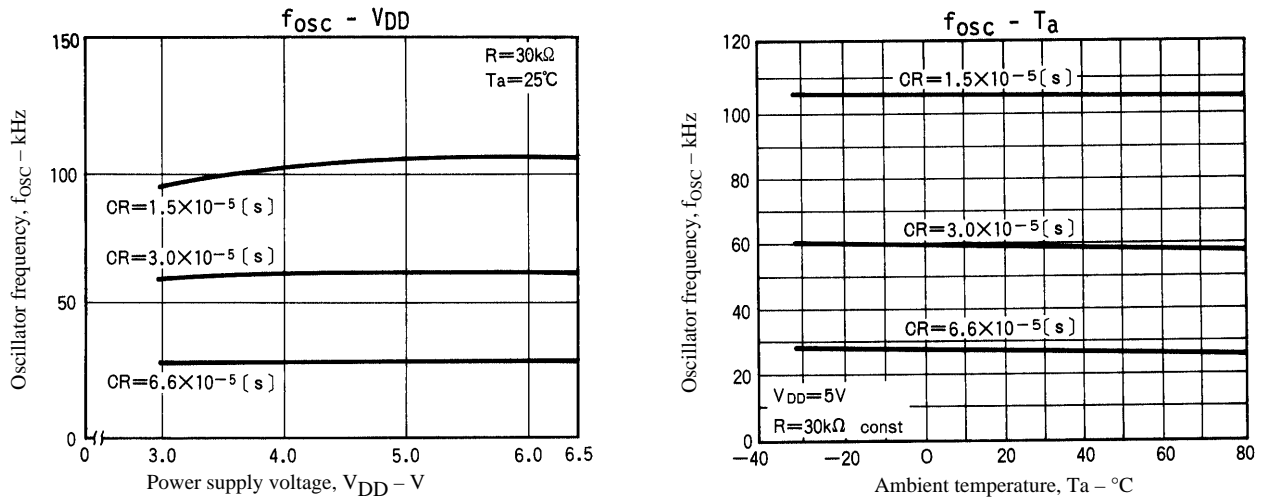

Figure 2 LC75821E, 75821W Oscillator Frequency vs. V_{DD}

Recommended range for external resistance: 10 to 100 k Ω (Carbon resistance)

Recommended range for external capacitance: 330 to 3300 pF

330 to 820 pF: (Ceramic capacitance with a zero temperature coefficient)

1000 to 3300 pF: (Mylar capacitance with a positive temperature coefficient)

- No products described or contained herein are intended for use in surgical implants, life-support systems, aerospace equipment, nuclear power control systems, vehicles, disaster/crime-prevention equipment and the like, the failure of which may directly or indirectly cause injury, death or property loss.
- Anyone purchasing any products described or contained herein for an above-mentioned use shall:
 - ① Accept full responsibility and indemnify and defend SANYO ELECTRIC CO., LTD., its affiliates, subsidiaries and distributors and all their officers and employees, jointly and severally, against any and all claims and litigation and all damages, cost and expenses associated with such use:
 - ② Not impose any responsibility for any fault or negligence which may be cited in any such claim or litigation on SANYO ELECTRIC CO., LTD., its affiliates, subsidiaries and distributors or any of their officers and employees jointly or severally.
- Information (including circuit diagrams and circuit parameters) herein is for example only; it is not guaranteed for volume production. SANYO believes information herein is accurate and reliable, but no guarantees are made or implied regarding its use or any infringements of intellectual property rights or other rights of third parties.

This catalog provides information as of February, 1998. Specifications and information herein are subject to change without notice.