

FEATURES

- **Input Offset Voltage: 75 μ V (Max)**
- **60V Supply Operation (LT1787HV)**
- **12-Bit Dynamic Range**
- Operating Current: 60 μ A
- User-Selectable External Sense Resistor
- Bidirectional High Side Current Sensing
- Unidirectional or Bidirectional Output
- Input Noise Filtering
- Available in 8-Lead SO and MSOP Packages
- -40°C to 125°C Operating Temperature Range

APPLICATIONS

- Battery Monitoring
- Power Monitoring
- Portable Phones
- Cellular Phones
- Portable Test/Measurement Systems
- Battery-Operated Systems

DESCRIPTION

The LT[®]1787 is a complete micropower precision high side current sense amplifier. The LT1787 monitors bidirectional currents via the voltage across an external sense resistor. A current or voltage output indicates the direction and magnitude of the sense current. The LT1787 delivers greater than a 12-bit dynamic range with ultralow 40 μ V input offset voltage compared to a typical 250mV full-scale input voltage. A fixed gain of 8 is set by onboard precision resistors. Input signal filtering is easily implemented with a capacitor between the FIL⁻ and FIL⁺ pins. The LT1787HV operates from 2.5V to 60V total supply voltage and the LT1787 operates from 2.5V to 36V total supply voltage. Both versions have a PSRR in excess of 120dB. The LT1787/LT1787HV draw only 60 μ A and are available in 8-lead SO and MSOP packages.

LT, LTC and LT are registered trademarks of Linear Technology Corporation.

TYPICAL APPLICATION

12-Bit Dynamic Resolution Unidirectional Output into LTC[®]1286 ADC

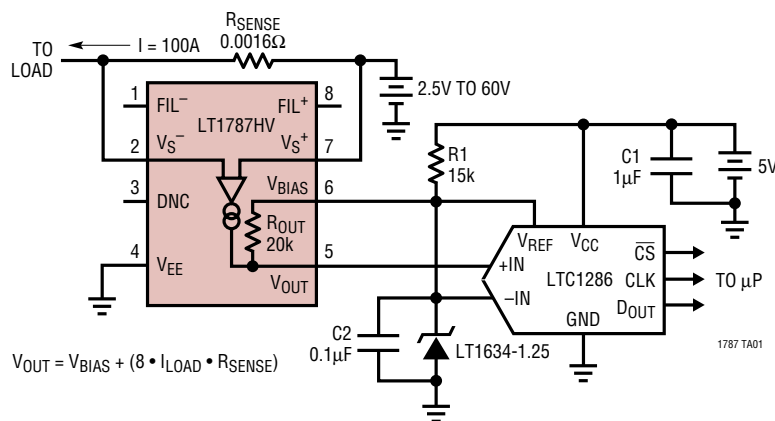

Input Offset Voltage vs Supply Voltage

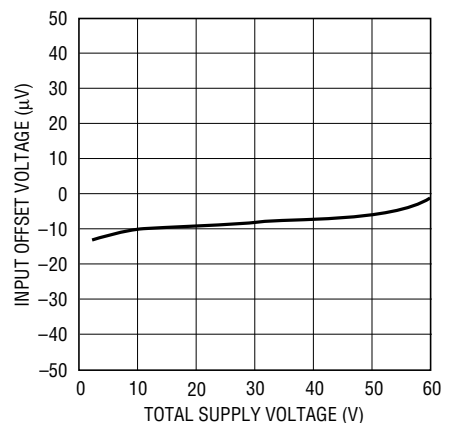

1787 TA01b

LT1787/LT1787HV

ABSOLUTE MAXIMUM RATINGS (Notes 1, 2)

| | | | |
|---------------------------------------|---------------------------------------|--|----------------------------------|
| Differential Sense Voltage | $\pm 10V$ | Specified Temperature Range (Note 4) | |
| Total Supply Voltage (LT1787) | 40V | LT1787C | $-40^{\circ}C$ to $85^{\circ}C$ |
| Total Supply Voltage (LT1787HV) | 65V | LT1787I | $-40^{\circ}C$ to $85^{\circ}C$ |
| Output Voltage | $(V_{EE} - 0.3V)$ to $(V_{EE} + 35V)$ | LT1787H | $-40^{\circ}C$ to $125^{\circ}C$ |
| Output Bias Voltage | $(V_{EE} - 0.3V)$ to $(V_{EE} + 35V)$ | Storage Temperature Range | $-65^{\circ}C$ to $150^{\circ}C$ |
| Operating Temperature Range (Note 3) | | Lead Temperature (Soldering, 10 sec) | $300^{\circ}C$ |
| LT1787C | $-40^{\circ}C$ to $85^{\circ}C$ | | |
| LT1787I | $-40^{\circ}C$ to $85^{\circ}C$ | | |
| LT1787H | $-40^{\circ}C$ to $125^{\circ}C$ | | |

PACKAGE/ORDER INFORMATION

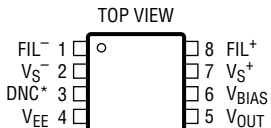
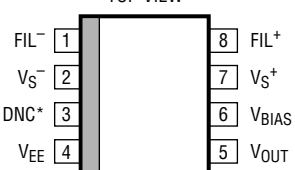
| | ORDER PART NUMBER | | ORDER PART NUMBER | | | | |
|---|--|---|--|------|--------|-------|--------|
|  <p>MS8 PACKAGE 8-LEAD PLASTIC MSOP</p> <p>* DO NOT CONNECT</p> <p>$T_{JMAX} = 150^{\circ}C$, $\theta_{JA} = 250^{\circ}C/W$</p> | LT1787CMS8 LT1787IMS8 LT1787HVCMS8 LT1787HVIMS8 |  <p>S8 PACKAGE 8-LEAD PLASTIC SO</p> <p>* DO NOT CONNECT</p> <p>$T_{JMAX} = 150^{\circ}C$, $\theta_{JA} = 190^{\circ}C/W$</p> | LT1787CS8 LT1787IS8 LT1787HS8 LT1787HVCS8 LT1787HVIS8 LT1787HVHS8 | | | | |
| | MS8 PART MARKING | | S8 PART MARKING | | | | |
| | LTGM LTGN LTKJ LTKK | | <table border="0"> <tr> <td>1787</td> <td>1787HV</td> </tr> <tr> <td>1787I</td> <td>787HVI</td> </tr> <tr> <td>1787H</td> <td>787HVH</td> </tr> </table> | 1787 | 1787HV | 1787I | 787HVI |
| 1787 | 1787HV | | | | | | |
| 1787I | 787HVI | | | | | | |
| 1787H | 787HVH | | | | | | |

Consult factory for parts specified with wider operating temperature ranges.

ELECTRICAL CHARACTERISTICS (Note 5)

The ● denotes the specifications which apply over the temperature range $0^{\circ}C \leq T_A \leq 70^{\circ}C$, otherwise specifications are at $T_A = 25^{\circ}C$. Total supply = $(V_{S^-} - V_{EE}) = 2.5V$ to $36V$ (LT1787C), $2.5V$ to $60V$ (LT1787HVC) unless otherwise specified.

| SYMBOL | PARAMETER | CONDITIONS | MIN | TYP | MAX | UNITS | |
|--------------------|--------------------------------|--|-----|------|----------|-------|---------|
| V_{S^-}, V_{S^+} | Sense Amplifier Supply Voltage | Single Supply Operation (LT1787) | ● | 2.5 | 36 | V | |
| | | Single Supply Operation (LT1787HV) | ● | 2.5 | 60 | V | |
| V_{SENSE} | Input Sense Voltage Full Scale | $V_{SENSE} = V_{S^+} - V_{S^-}$, $V_S = 10V$, $V_{BIAS} = 5V$, $A_V = 8 \pm 10\%$ | ● | 500 | | mV | |
| V_{OS} | Input Offset Voltage (S8) | $I_{OUT} = 0$, V_S Supply = 5V $0^{\circ}C \leq T_A \leq 70^{\circ}C$ | ● | -75 | ± 40 | 75 | μV |
| | | $I_{OUT} = 0$ (LT1787) $0^{\circ}C \leq T_A \leq 70^{\circ}C$ | ● | -135 | | 135 | μV |
| | | $I_{OUT} = 0$ (LT1787HV) $0^{\circ}C \leq T_A \leq 70^{\circ}C$ | ● | -100 | | 100 | μV |
| | Input Offset Voltage (MS8) | $I_{OUT} = 0$, V_S Supply = 5V $0^{\circ}C \leq T_A \leq 70^{\circ}C$ | ● | -125 | ± 40 | 125 | μV |
| | | $I_{OUT} = 0$ (LT1787) $0^{\circ}C \leq T_A \leq 70^{\circ}C$ | ● | -230 | | 230 | μV |
| | | $I_{OUT} = 0$ (LT1787HV) $0^{\circ}C \leq T_A \leq 70^{\circ}C$ | ● | -150 | | 150 | μV |
| | | $I_{OUT} = 0$ (LT1787HV) $0^{\circ}C \leq T_A \leq 70^{\circ}C$ | ● | -250 | | 250 | μV |
| | | $I_{OUT} = 0$ (LT1787HV) $0^{\circ}C \leq T_A \leq 70^{\circ}C$ | ● | -150 | | 150 | μV |
| | | $I_{OUT} = 0$ (LT1787HV) $0^{\circ}C \leq T_A \leq 70^{\circ}C$ | ● | -250 | | 250 | μV |

ELECTRICAL CHARACTERISTICS (Note 5)

The ● denotes the specifications which apply over the temperature range $0^{\circ}\text{C} \leq T_A \leq 70^{\circ}\text{C}$, otherwise specifications are at $T_A = 25^{\circ}\text{C}$. Total supply = $(V_S^- - V_{EE}) = 2.5\text{V to } 36\text{V}$ (LT1787C), 2.5V to 60V (LT1787HVC) unless otherwise specified.

| SYMBOL | PARAMETER | CONDITIONS | MIN | TYP | MAX | UNITS | |
|---|--|---|-----|----------------------|--------------|--------------------------------|-----|
| V_{OS} TC | Temperature Coefficient of V_{OS} | V_S Supply = 5V (Note 6) | ● | 0.5 | 2 | $\mu\text{V}/^{\circ}\text{C}$ | |
| $I_{OUT(0)}$ | No-Load Output Current Error | $V_{SENSE} = 0\text{V}$ | | 4 | | nA | |
| $V_{OUT(0)}$ | No-Load Output Voltage Error (S8) | $V_{SENSE} = 0\text{V}$, V_S Supply = 5V $0^{\circ}\text{C} \leq T_A \leq 70^{\circ}\text{C}$ | ● | -600 -1080 | 600 1080 | μV μV | |
| | No-Load Output Voltage Error (MS8) | $V_{SENSE} = 0\text{V}$, V_S Supply = 5V $0^{\circ}\text{C} \leq T_A \leq 70^{\circ}\text{C}$ | ● | -1000 -1840 | 1000 1840 | μV μV | |
| g_m | Transconductance, I_{OUT}/V_{SENSE} | $\pm V_{SENSE} = 10\text{mV}, 50\text{mV}, 100\text{mV}, 150\text{mV}, 250\text{mV}$, V_S Supply = Total Supply + $ V_{SENSE} $ | | 400 | | $\mu\text{A}/\text{V}$ | |
| A_V | Gain, V_{OUT}/V_{SENSE} | $\pm V_{SENSE} = 100\text{mV}$, V_S Supply = 5V | ● | 7.6 | 8 | 8.4 | V/V |
| | Output Voltage Gain Error | $\pm V_{SENSE} = 100\text{mV}$, V_S Supply = 5V | ● | -5 | 2 | 5 | % |
| V_S PSRR | V_S Supply Rejection Ratio | $V_{SENSE} = 0\text{V}$, V_S Supply = 2.5V to 36V (LT1787) | ● | 120 | 135 | | dB |
| | | $V_{SENSE} = 0\text{V}$, V_S Supply = 2.5V to 60V (LT1787HV) | ● | 120 | 135 | | dB |
| V_{EE} PSRR | Negative Supply Rejection Ratio | $V_{SENSE} = 0\text{V}$, V_S Supply = 15V, $V_{BIAS} = 0\text{V}$, $V_{EE} = -1\text{V to } -15\text{V}$ (LT1787) | ● | 100 | 130 | | dB |
| | | $V_{SENSE} = 0\text{V}$, V_S Supply = 40V, $V_{BIAS} = 0\text{V}$, $V_{EE} = -1\text{V to } -15\text{V}$ (LT1787HV) | ● | 100 | 130 | | dB |
| $\frac{\Delta V_{OS}}{\Delta V_{BIAS}}$ | Change in Input Offset Voltage with Change in V_{BIAS} Voltage | $V_{SENSE} = 0\text{V}$, V_S Supply = 36V, $V_{BIAS} = 0.5\text{V to } 25\text{V}$ (LT1787) | ● | 100 | 130 | | dB |
| | | $V_{SENSE} = 0\text{V}$, V_S Supply = 60V, $V_{BIAS} = 0.5\text{V to } 25\text{V}$ (LT1787HV) | ● | 100 | 130 | | dB |
| $I_S^+(0)$ | Positive Input Sense Current | $V_{SENSE} = 0\text{V}$ | ● | 10 | 20 | μA | |
| $I_S^-(0)$ | Negative Input Sense Current | $V_{SENSE} = 0\text{V}$ | ● | 50 | 100 | μA | |
| $I_{EE(0)}$ | Negative Supply Current | $V_{SENSE} = 0\text{V}$ | ● | 60 | 120 | μA | |
| I_{OUT} | Output Current | $V_{SENSE} = \pm 128\text{mV}$ | | ± 50 | | μA | |
| V_{OUT} | Output Voltage | $V_{SENSE} = \pm 128\text{mV}$, $V_S^+ \geq 3.3\text{V}$ | | $V_{BIAS} \pm 1.024$ | | V | |
| | Ripple Rejection | $V_S^+ = V_S^- = 20\text{V}$, ΔV_S Supply = 1V, $f = 1\text{kHz}$ | ● | 80 | 88 | | dB |
| V_{OMIN} | Minimum Output Voltage | $V_{SENSE} = 0\text{V}$, $V_{BIAS} = 0\text{V}$ | ● | 30 | 45 | | mV |
| | | $V_{SENSE} = V_S^+ - V_S^- = -128\text{mV}$, $V_{BIAS} = 0\text{V}$ | | 10 | | | mV |
| | Unipolar Output Saturation Voltage | $V_{SENSE} = 2\text{mV}$, $V_{BIAS} = 0\text{V}$ | ● | | 32 | 50 | mV |
| | | $V_{SENSE} = 4\text{mV}$, $V_{BIAS} = 0\text{V}$ | ● | | 38 | 55 | mV |
| | | $V_{SENSE} = 5\text{mV}$, $V_{BIAS} = 0\text{V}$ | ● | | 43 | 60 | mV |
| $V_{SENSE} = 6\text{mV}$, $V_{BIAS} = 0\text{V}$ | ● | | 49 | 65 | mV | | |
| V_{OMAX} | Maximum Output Voltage | | | $V_S^+ - 0.75$ | | V | |
| R_{G1A}, R_{G2A} | Input Gain-Setting Resistor | Pin 1 to Pin 2, Pin 7 to Pin 8 | | 1.25 | | k Ω | |
| R_{OUT} | Output Resistor | Pin 5 to Pin 6 | | 20 | | k Ω | |

The ● denotes the specifications which apply over the temperature range $-40^{\circ}\text{C} \leq T_A \leq 85^{\circ}\text{C}$, otherwise specifications are at $T_A = 25^{\circ}\text{C}$. Total supply = $(V_S^- - V_{EE}) = 2.5\text{V to } 36\text{V}$ (LT1787I), 2.5V to 60V (LT1787HVI) unless otherwise specified.

| SYMBOL | PARAMETER | CONDITIONS | MIN | TYP | MAX | UNITS |
|----------------|--------------------------------|--|-----|--------------|-----------------|--------------------------------|
| V_S^-, V_S^+ | Sense Amplifier Supply Voltage | Single Supply Operation (LT1787) | ● | 2.5 | 36 | V |
| | | Single Supply Operation (LT1787HV) | ● | 2.5 | 60 | V |
| V_{SENSE} | Input Sense Voltage Full Scale | $V_{SENSE} = V_S^+ - V_S^-$, $V_S = 10\text{V}$, $V_{BIAS} = 5\text{V}$, $A_V = 8 \pm 10\%$ | ● | 500 | | mV |
| V_{OS} | Input Offset Voltage (S8) | $I_{OUT} = 0$, V_S Supply = 5V $-40^{\circ}\text{C} \leq T_A \leq 85^{\circ}\text{C}$ | ● | -75 -200 | ± 40 200 | μV μV |
| | | $I_{OUT} = 0$ (LT1787) $-40^{\circ}\text{C} \leq T_A \leq 85^{\circ}\text{C}$ | ● | -100 -225 | 100 225 | μV μV |

ELECTRICAL CHARACTERISTICS (Note 5)

The ● denotes the specifications which apply over the temperature range $-40^{\circ}\text{C} \leq T_A \leq 85^{\circ}\text{C}$, otherwise specifications are at $T_A = 25^{\circ}\text{C}$. Total supply = $(V_S^- - V_{EE}) = 2.5\text{V to }36\text{V}$ (LT1787I), $2.5\text{V to }60\text{V}$ (LT1787HVI) unless otherwise specified.

| SYMBOL | PARAMETER | CONDITIONS | MIN | TYP | MAX | UNITS | |
|---|--|---|----------------------------|----------------------|--------------|--------------------------------|--------------------------------|
| | | $I_{OUT} = 0$ (LT1787HV) $-40^{\circ}\text{C} \leq T_A \leq 85^{\circ}\text{C}$ | ● -100 -225 | | 100 225 | μV μV | |
| | Input Offset Voltage (MS8) | $I_{OUT} = 0$, V_S Supply = 5V $-40^{\circ}\text{C} \leq T_A \leq 85^{\circ}\text{C}$ | ● -125 -250 | ± 40 | 125 250 | μV μV | |
| | | $I_{OUT} = 0$ (LT1787) $-40^{\circ}\text{C} \leq T_A \leq 85^{\circ}\text{C}$ | ● -150 -280 | | 150 280 | μV μV | |
| | | $I_{OUT} = 0$ (LT1787HV) $-40^{\circ}\text{C} \leq T_A \leq 85^{\circ}\text{C}$ | ● -150 -280 | | 150 280 | μV μV | |
| V_{OS} TC | | Temperature Coefficient of V_{OS} | V_S Supply = 5V (Note 6) | ● | 0.5 | 2 | $\mu\text{V}/^{\circ}\text{C}$ |
| $I_{OUT(0)}$ | No-Load Output Current Error | $V_{SENSE} = 0\text{V}$ | | 4 | | nA | |
| $V_{OUT(0)}$ | No-Load Output Voltage Error (S8) | $V_{SENSE} = 0\text{V}$, V_S Supply = 5V $-40^{\circ}\text{C} \leq T_A \leq 85^{\circ}\text{C}$ | ● -600 -1600 | | 600 1600 | μV μV | |
| | No-Load Output Voltage Error (MS8) | $V_{SENSE} = 0\text{V}$, V_S Supply = 5V $-40^{\circ}\text{C} \leq T_A \leq 85^{\circ}\text{C}$ | ● -1000 -2000 | | 1000 2000 | μV μV | |
| g_m | Transconductance, I_{OUT}/V_{SENSE} | $\pm V_{SENSE} = 10\text{mV}, 50\text{mV}, 100\text{mV}, 150\text{mV}, 250\text{mV}$, V_S Supply = Total Supply + $ V_{SENSE} $ | | 400 | | $\mu\text{A}/\text{V}$ | |
| A_V | Gain, V_{OUT}/V_{SENSE} | $\pm V_{SENSE} = 100\text{mV}$, V_S Supply = 5V | ● 7.6 | 8 | 8.4 | V/V | |
| | Output Voltage Gain Error | $\pm V_{SENSE} = 100\text{mV}$, V_S Supply = 5V | ● -5 | 2 | 5 | % | |
| V_S PSRR | V_S Supply Rejection Ratio | $V_{SENSE} = 0\text{V}$, V_S Supply = 2.5V to 36V (LT1787) | ● 120 | 135 | | dB | |
| | | $V_{SENSE} = 0\text{V}$, V_S Supply = 2.5V to 60V (LT1787HV) | ● 120 | 135 | | dB | |
| V_{EE} PSRR | Negative Supply Rejection Ratio | $V_{SENSE} = 0\text{V}$, V_S Supply = 15V, $V_{BIAS} = 0\text{V}$, $V_{EE} = -1\text{V to }-15\text{V}$ (LT1787) | ● 100 | 130 | | dB | |
| | | $V_{SENSE} = 0\text{V}$, V_S Supply = 40V, $V_{BIAS} = 0\text{V}$, $V_{EE} = -1\text{V to }-15\text{V}$ (LT1787HV) | ● 100 | 130 | | dB | |
| $\frac{\Delta V_{OS}}{\Delta V_{BIAS}}$ | Change in Input Offset Voltage with Change in V_{BIAS} Voltage | $V_{SENSE} = 0\text{V}$, V_S Supply = 36V, $V_{BIAS} = 0.5\text{V to }25\text{V}$ (LT1787) | ● 100 | 130 | | dB | |
| | | $V_{SENSE} = 0\text{V}$, V_S Supply = 60V, $V_{BIAS} = 0.5\text{V to }25\text{V}$ (LT1787HV) | ● 100 | 130 | | dB | |
| $I_S^+(0)$ | Positive Input Sense Current | $V_{SENSE} = 0\text{V}$ | ● | 10 | 20 | μA | |
| $I_S^-(0)$ | Negative Input Sense Current | $V_{SENSE} = 0\text{V}$ | ● | 50 | 100 | μA | |
| $I_{EE(0)}$ | Negative Supply Current | $V_{SENSE} = 0\text{V}$ | ● | 60 | 120 | μA | |
| I_{OUT} | Output Current | $V_{SENSE} = \pm 128\text{mV}$ | | ± 50 | | μA | |
| V_{OUT} | Output Voltage | $V_{SENSE} = \pm 128\text{mV}$, $V_S^+ \geq 3.3\text{V}$ | | $V_{BIAS} \pm 1.024$ | | V | |
| | Ripple Rejection | $V_S^+ = V_S^- = 20\text{V}$, ΔV_S Supply = 1V, $f = 1\text{kHz}$ | ● 80 | 88 | | dB | |
| V_{OMIN} | Minimum Output Voltage | $V_{SENSE} = 0\text{V}$, $V_{BIAS} = 0\text{V}$ | ● | 30 | 45 | mV | |
| | | $V_{SENSE} = V_S^+ - V_S^- = -128\text{mV}$, $V_{BIAS} = 0\text{V}$ | | 10 | | mV | |
| | Unipolar Output Saturation Voltage | $V_{SENSE} = 2\text{mV}$, $V_{BIAS} = 0\text{V}$ | ● | | 32 | 50 | mV |
| | | $V_{SENSE} = 4\text{mV}$, $V_{BIAS} = 0\text{V}$ | ● | | 38 | 55 | mV |
| | | $V_{SENSE} = 5\text{mV}$, $V_{BIAS} = 0\text{V}$ | ● | | 43 | 60 | mV |
| $V_{SENSE} = 6\text{mV}$, $V_{BIAS} = 0\text{V}$ | ● | | 49 | 65 | mV | | |
| V_{OMAX} | Maximum Output Voltage | | | $V_S^+ - 0.75$ | | V | |
| R_{G1A}, R_{G2A} | Input Gain-Setting Resistor | Pin 1 to Pin 2, Pin 7 to Pin 8 | | 1.25 | | k Ω | |
| R_{OUT} | Output Resistor | Pin 5 to Pin 6 | | 20 | | k Ω | |

ELECTRICAL CHARACTERISTICS (Note 5)

The ● denotes the specifications which apply over the temperature range $-40^{\circ}\text{C} \leq T_A \leq 125^{\circ}\text{C}$, otherwise specifications are at $T_A = 25^{\circ}\text{C}$. Total supply = $(V_S^- - V_{EE}) = 2.5\text{V to }36\text{V}$ (LT1787H), $2.5\text{V to }60\text{V}$ (LT1787HVH) unless otherwise specified.

| SYMBOL | PARAMETER | CONDITIONS | MIN | TYP | MAX | UNITS |
|---|--|---|---------|----------------------|------|-----------------|
| V_S^-, V_S^+ | Sense Amplifier Supply Voltage | Single Supply Operation (LT1787H) | ● 2.5 | | 36 | V |
| | | Single Supply Operation (LT1787HVH) | ● 2.5 | | 60 | V |
| V_{SENSE} | Input Sense Voltage Full Scale | $V_{SENSE} = V_S^+ - V_S^-$, $V_S = 10\text{V}$, $V_{BIAS} = 5\text{V}$, $A_V = 8 \pm 10\%$ | ● 500 | | | mV |
| V_{OS} | Input Offset Voltage | $I_{OUT} = 0$, V_S Supply = 5V $-40^{\circ}\text{C} \leq T_A \leq 125^{\circ}\text{C}$ | ● -75 | ± 40 | 75 | μV |
| | | $I_{OUT} = 0$ (LT1787H) $-40^{\circ}\text{C} \leq T_A \leq 125^{\circ}\text{C}$ | ● -400 | | 400 | μV |
| | | $I_{OUT} = 0$ (LT1787HVH) $-40^{\circ}\text{C} \leq T_A \leq 125^{\circ}\text{C}$ | ● -100 | | 100 | μV |
| V_{OS} TC | Temperature Coefficient of V_{OS} | V_S Supply = 5V (Note 6) | ● -550 | | 550 | μV |
| | | | ● -100 | | 100 | μV |
| $I_{OUT(0)}$ | No-Load Output Current Error | $V_{SENSE} = 0\text{V}$ | | 4 | | nA |
| $V_{OUT(0)}$ | No-Load Output Voltage Error | $V_{SENSE} = 0\text{V}$, V_S Supply = 5V $-40^{\circ}\text{C} \leq T_A \leq 125^{\circ}\text{C}$ | ● -600 | | 600 | μV |
| g_m | Transconductance, I_{OUT}/V_{SENSE} | $\pm V_{SENSE} = 10\text{mV}, 50\text{mV}, 100\text{mV}, 150\text{mV}, 250\text{mV}$, V_S Supply = Total Supply + $ V_{SENSE} $ | ● -3200 | | 3200 | μV |
| | | | | | 400 | $\mu\text{A/V}$ |
| A_V | Gain, V_{OUT}/V_{SENSE} | $\pm V_{SENSE} = 100\text{mV}$, V_S Supply = 5V | ● 7.6 | 8 | 8.4 | V/V |
| | Output Voltage Gain Error | $\pm V_{SENSE} = 100\text{mV}$, V_S Supply = 5V | ● -5 | 2 | 5 | % |
| V_S PSRR | V_S Supply Rejection Ratio | $V_{SENSE} = 0\text{V}$, V_S Supply = 2.5V to 36V (LT1787H) | ● 100 | 130 | | dB |
| | | $V_{SENSE} = 0\text{V}$, V_S Supply = 2.5V to 60V (LT1787HVH) | ● 100 | 130 | | dB |
| V_{EE} PSRR | Negative Supply Rejection Ratio | $V_{SENSE} = 0\text{V}$, V_S Supply = 15V, $V_{BIAS} = 0\text{V}$, $V_{EE} = -1\text{V to }-15\text{V}$ (LT1787H) | ● 100 | 130 | | dB |
| | | $V_{SENSE} = 0\text{V}$, V_S Supply = 40V, $V_{BIAS} = 0\text{V}$, $V_{EE} = -1\text{V to }-15\text{V}$ (LT1787HVH) | ● 100 | 130 | | dB |
| $\frac{\Delta V_{OS}}{\Delta V_{BIAS}}$ | Change in Input Offset Voltage with Change in V_{BIAS} Voltage | $V_{SENSE} = 0\text{V}$, V_S Supply = 36V, $V_{BIAS} = 0.5\text{V to }25\text{V}$ (LT1787H) | ● 100 | 130 | | dB |
| | | $V_{SENSE} = 0\text{V}$, V_S Supply = 60V, $V_{BIAS} = 0.5\text{V to }25\text{V}$ (LT1787HVH) | ● 100 | 130 | | dB |
| $I_S^+(0)$ | Positive Input Sense Current | $V_{SENSE} = 0\text{V}$ | ● | 10 | 25 | μA |
| $I_S^-(0)$ | Negative Input Sense Current | $V_{SENSE} = 0\text{V}$ | ● | 50 | 115 | μA |
| $I_{EE(0)}$ | Negative Supply Current | $V_{SENSE} = 0\text{V}$ | ● | 60 | 140 | μA |
| I_{OUT} | Output Current | $V_{SENSE} = \pm 128\text{mV}$ | | ± 50 | | μA |
| V_{OUT} | Output Voltage | $V_{SENSE} = \pm 128\text{mV}$, $V_S^+ \geq 3.3\text{V}$ | | $V_{BIAS} \pm 1.024$ | | V |
| | Ripple Rejection | $V_S^+ = V_S^- = 20\text{V}$, ΔV_S Supply = 1V, $f = 1\text{kHz}$ | ● 80 | 88 | | dB |
| V_{OMIN} | Minimum Output Voltage | $V_{SENSE} = 0\text{V}$, $V_{BIAS} = 0\text{V}$ | ● | 30 | 55 | mV |
| | | $V_{SENSE} = V_S^+ - V_S^- = -128\text{mV}$, $V_{BIAS} = 0\text{V}$ | | 10 | | mV |
| | Unipolar Output Saturation Voltage | $V_{SENSE} = 2\text{mV}$, $V_{BIAS} = 0\text{V}$ | ● | 32 | 60 | mV |
| | | $V_{SENSE} = 4\text{mV}$, $V_{BIAS} = 0\text{V}$ | ● | 38 | 65 | mV |
| | | $V_{SENSE} = 5\text{mV}$, $V_{BIAS} = 0\text{V}$ | ● | 43 | 70 | mV |
| | | $V_{SENSE} = 6\text{mV}$, $V_{BIAS} = 0\text{V}$ | ● | 49 | 75 | mV |
| V_{OMAX} | Maximum Output Voltage | | | $V_S^+ - 0.75$ | | V |
| R_{G1A}, R_{G2A} | Input Gain-Setting Resistor | Pin 1 to Pin 2, Pin 7 to Pin 8 | | 1.25 | | k Ω |
| R_{OUT} | Output Resistor | Pin 5 to Pin 6 | | 20 | | k Ω |

ELECTRICAL CHARACTERISTICS

Note 1: Absolute Maximum Ratings are those values beyond which the life of a device may be impaired.

Note 2: ESD (Electrostatic Discharge) sensitive devices. Extensive use of ESD protection devices are used internal to the LT1787/LT1787HV, however, high electrostatic discharge can damage or degrade the device. Use proper ESD handling precautions.

Note 3: The LT1787C/LT1787I are guaranteed functional over the operating temperature range of -40°C to 85°C . The LT1787H is guaranteed functional over the operating temperature range of -40°C to 125°C .

Note 4: The LT1787C is guaranteed to meet specified performance from 0°C to 70°C . The LT1787C is designed, characterized and expected to meet specified performance from -40°C to 85°C but is not tested or QA sampled at these temperatures. The LT1787I is guaranteed to meet specified performance from -40°C to 85°C . The LT1787H is guaranteed to meet specified performance from -40°C to 125°C .

Note 5: Testing done at $V_{\text{BIAS}} = 1.25\text{V}$, $V_{\text{EE}} = 0\text{V}$ unless otherwise specified.

Note 6: This parameter is not 100% tested.

TYPICAL PERFORMANCE CHARACTERISTICS

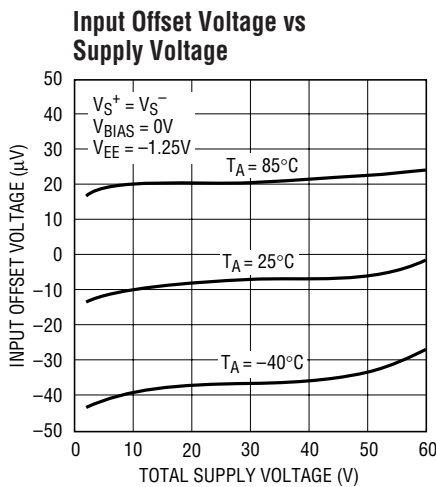

1787 G01

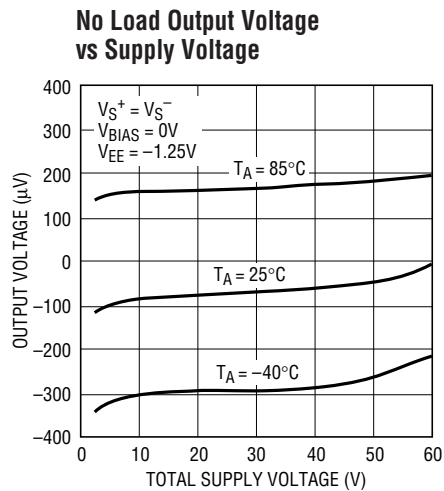

1787 G02

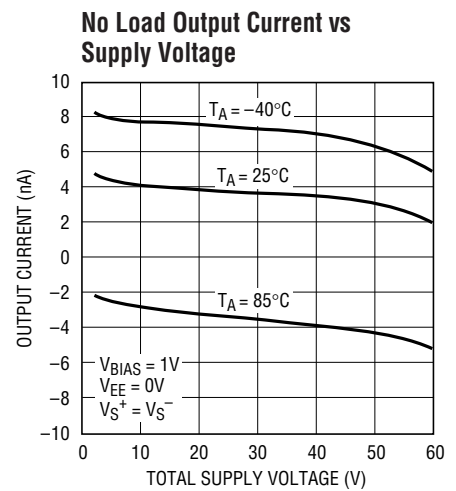

1787 G03

TYPICAL PERFORMANCE CHARACTERISTICS

Input Offset Voltage vs Negative Supply Voltage

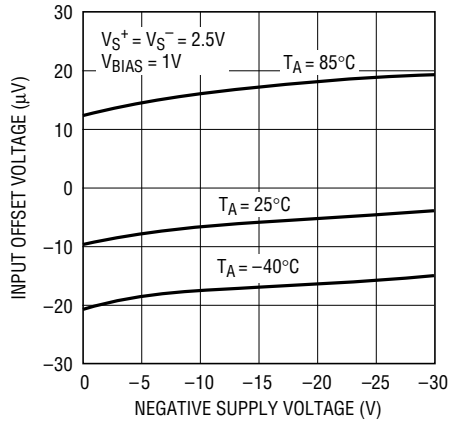

1787 G04

Input Offset Voltage vs Temperature

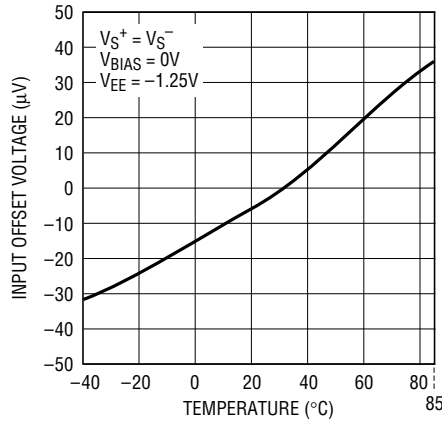

1787 G05

Output Voltage vs Sense Voltage (Bidirectional Mode)

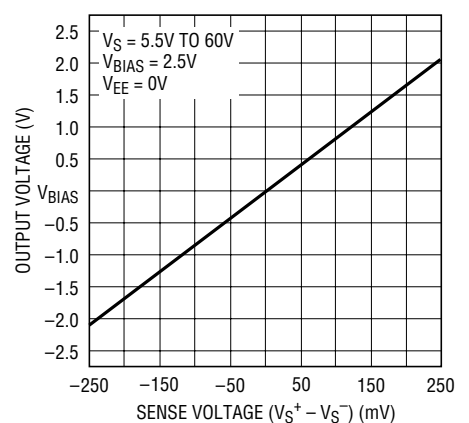

1787 G06

Output Voltage vs Sense Voltage (Unidirectional Mode)

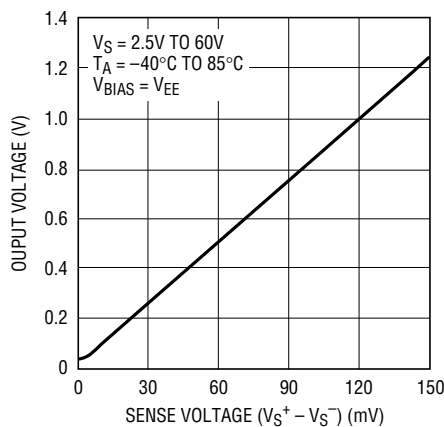

1787 G07

Gain vs Temperature

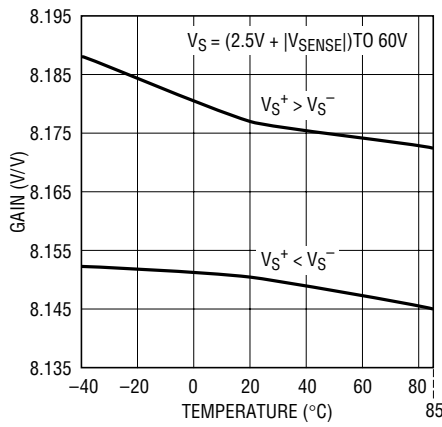

1787 G08

Gain vs Frequency

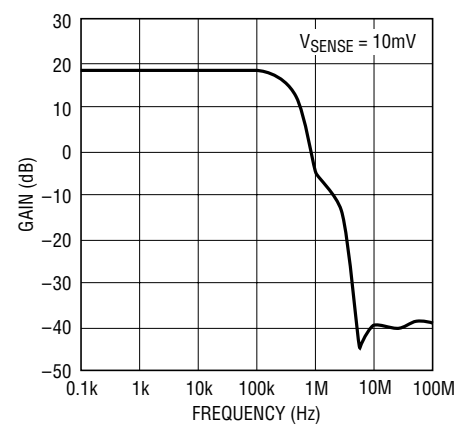

1787 G09

Supply Current vs Supply Voltage

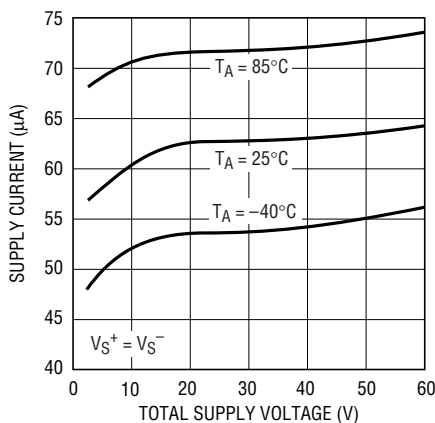

1787 G10

Negative Input Sense Current vs Sense Voltage

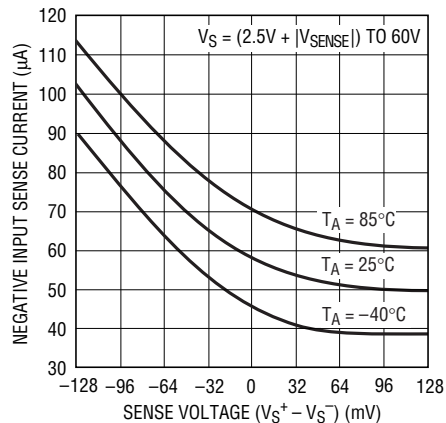

1787 G11

Positive Input Sense Current vs Sense Voltage

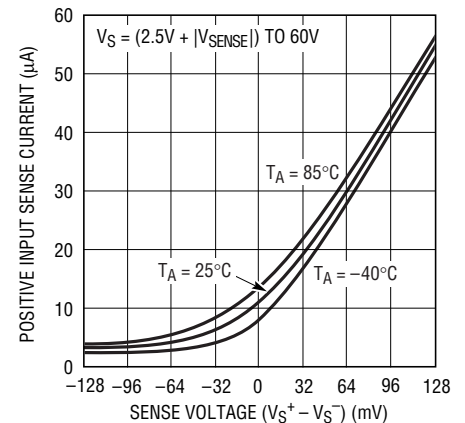

1787 G12

TYPICAL PERFORMANCE CHARACTERISTICS

Step Response at $V_{SENSE} = 0V$ to $10mV$

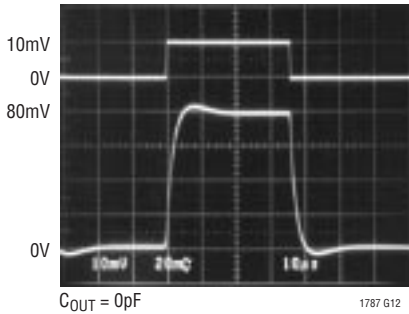

Step Response at $V_{SENSE} = 0V$ to $128mV$

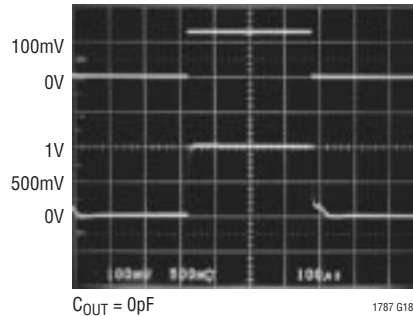

Step Response at $V_{SENSE} = 0V$ to $128mV$

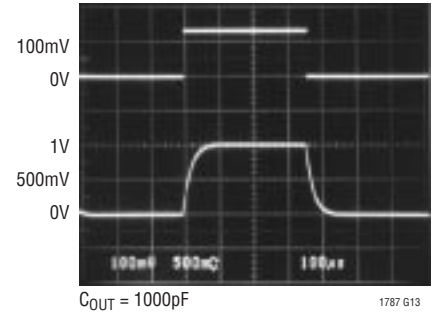

Step Response at $V_{SENSE} = 0V$ to $-128mV$

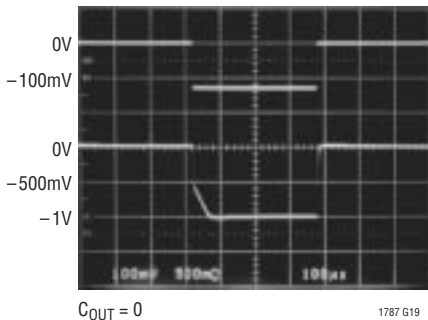

Step Response at $V_{SENSE} = 0V$ to $-128mV$

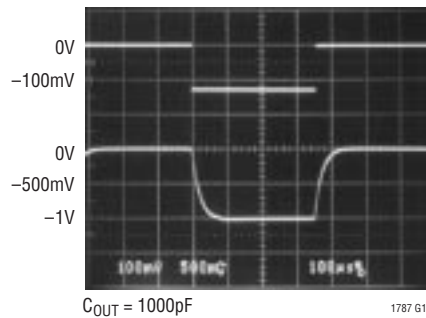

Step Response at $V_{SENSE} = -128mV$ to $128mV$

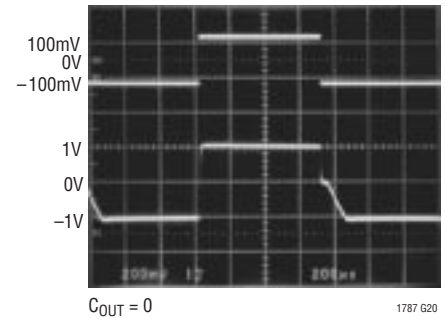

Step Response at $V_{SENSE} = 128mV$ to $-128mV$

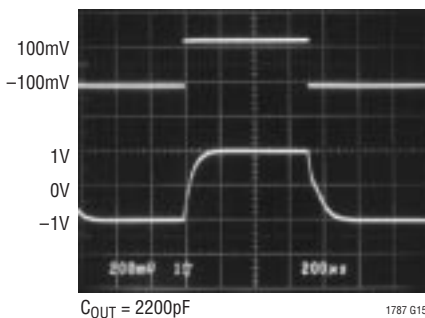

V_{OUT} Error vs Supply Ripple Voltage ($V_{SENSE} = \pm 128mV$)

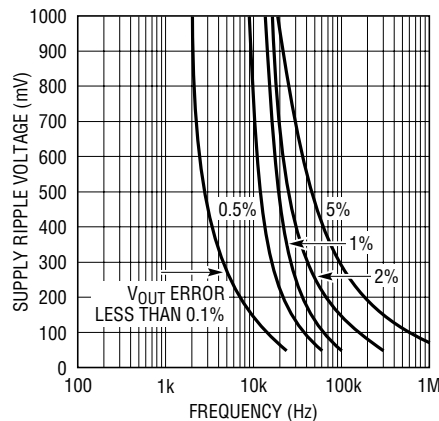

Output Voltage vs Sense Voltage

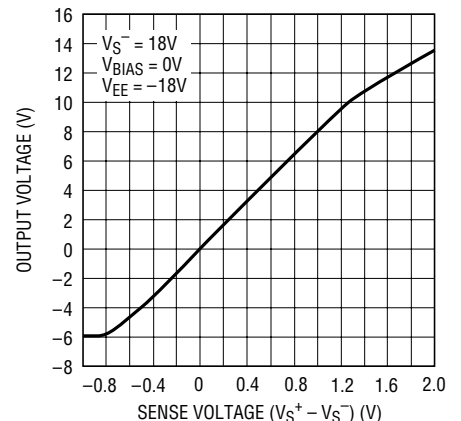

PIN FUNCTIONS

FIL⁻, FIL⁺ (Pins 1, 8): Negative and Positive Filter Terminals. Differential mode noise can be filtered by connecting a capacitor across FIL⁻ and FIL⁺. Pole frequency $f_{-3dB} = 1/(2\pi RC)$, $R = 1.25k\Omega$.

V_S⁻ (Pin 2): Negative Input Sense Terminal. Negative sense voltage will result in an output sinking current proportional to the sense current. V_S⁻ is connected to an internal gain-setting resistor R_{G1A} and supplies bias current to the internal amplifier.

DNC (Pin 3): Do Not Connect. Connected internally. Do not connect external circuitry to this pin.

V_{EE} (Pin 4): Negative Supply or Ground for Single Supply Operation.

V_{OUT} (Pin 5): Voltage Output or Current Output proportional to the magnitude of the sense current flowing through R_{SENSE}. For bidirectional current sensing operation, $V_{OUT} = A_V \cdot V_{SENSE} + V_{OUT(0)} + V_{BIAS}$.

where:

$$\begin{aligned} V_{OUT} &> V_{BIAS} \text{ for } V_{S^+} > V_{S^-} \\ V_{OUT} &< V_{BIAS} \text{ for } V_{S^+} < V_{S^-} \end{aligned}$$

V_{OUT(0)} is the no load output voltage at V_{SENSE} = 0V.

V_{BIAS} (Pin 6): Output Bias Pin. For single supply, bidirectional current sensing operation, V_{BIAS} is connected to an external bias voltage, so that at V_{SENSE} = 0V, V_{OUT} = V_{OUT(0)} + V_{BIAS}. For dual supply, bidirectional current sensing operation, V_{BIAS} is connected to ground. Thus, V_{OUT} = V_{OUT(0)} at V_{SENSE} = 0V.

V_S⁺ (Pin 7): Positive Input Sense Terminal. Positive sense voltage will result in an output sourcing current proportional to the sense current. V_S⁺ is connected to an internal gain-setting resistor R_{G2A}. Connecting a supply to V_S⁺ and a load to V_S⁻ will allow the LT1787 to measure its own supply current.

BLOCK DIAGRAM

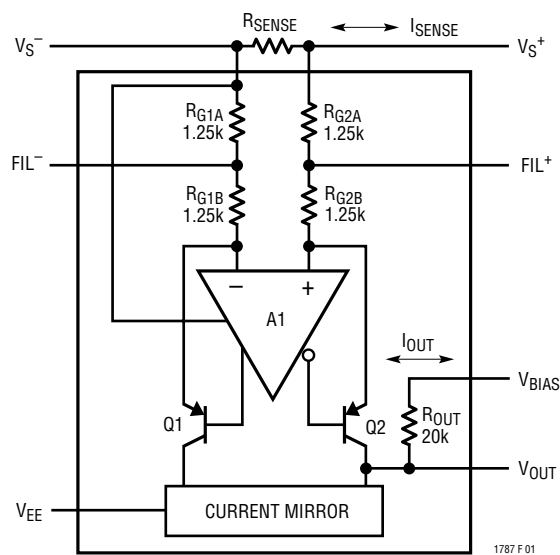

Figure 1. LT1787 Functional Diagram

APPLICATIONS INFORMATION

The LT1787 high side current sense amplifier (Figure 1) provides accurate bidirectional monitoring of current through a user-selected sense resistor. The sense voltage is amplified by a fixed gain of 8 and level shifted from the positive power supply to the ground referenced outputs. The output signal may be used in a variety of ways to interface with subsequent signal processing circuitry. Input and output filtering are easily implemented to eliminate aliasing errors.

Theory of Operation

Inputs V_S^+ and V_S^- apply the sense voltage to matched resistors R_{G1} and R_{G2} . The opposite ends of resistors R_{G1} and R_{G2} are forced to be at equal potentials by the voltage gain of amplifier A1. The currents through R_{G1} and R_{G2} are forced to flow through transistors Q1 and Q2 and are summed at node V_{OUT} by the 1:1 current mirror. The net current from R_{G1} and R_{G2} flowing through resistor R_{OUT} gives a voltage gain of eight. Positive sense voltages result in V_{OUT} being positive with respect to pin V_{BIAS} .

Pins V_{EE} , V_{BIAS} and V_{OUT} may be connected in a variety of ways to interface with subsequent circuitry. Split supply and single supply output configurations are shown in the following sections.

Supply current for amplifier A1 is drawn from the V_S^- pin. The user may choose to include this current in the monitored current through R_{SENSE} by careful choice of connection polarity.

Selection of External Current Sense Resistor

External R_{SENSE} resistor selection is a delicate trade-off between power dissipation in the resistor and current measurement accuracy. The LT1787 makes this decision less difficult than with competitors' products. The maximum sense voltage may be as large as $\pm 500\text{mV}$ to get maximum resolution, however, high current applications will not want to suffer this much power dissipation in the sense resistor. The LT1787's input offset voltage of $40\mu\text{V}$ gives high resolution for low sense voltages. This wide operating dynamic range gives the user wide latitude in tailoring the range and resolution of his supply monitoring function.

Kelvin connection of the LT1787's V_S^+ and V_S^- inputs to the sense resistor should be used in all but the lowest power applications. Solder connections and PC board interconnect resistance (approximately $0.5\text{m}\Omega$ per square) can be a large error in high current systems. A 5-Amp application might choose a $20\text{m}\Omega$ sense resistor to give a 100mV full-scale input to the LT1787. Input offset voltage will limit resolution to 2mA. Neglecting contact resistance at solder joints, even one square of PC board copper at each resistor end will cause an error of 5%. This error will grow proportionately higher as monitored current levels rise to tens or hundreds of amperes.

Input Noise Filtering

The LT1787 provides input signal filtering pins FIL^+ and FIL^- that are internally connected to the midpoint taps of resistors R_{G1} and R_{G2} . These pins may be used to filter the input signal entering the LT1787's internal amplifier, and should be used when fast current ripple or transients may flow through the sense resistor. High frequency signals above the 300kHz bandwidth of the LT1787's internal amplifier will cause errors. A capacitor connected between FIL^+ and FIL^- creates a single pole low pass filter with corner frequency:

$$f_{-3\text{dB}} = 1/(2\pi RC)$$

where $R = 1.25\text{k}$. A $0.01\mu\text{F}$ capacitor creates a pole at 12.7kHz, a good choice for many applications.

Common mode filtering from the FIL^+ and FIL^- pins should not be attempted, as mismatch in the capacitors from FIL^+ and FIL^- will create AC common mode errors. Common mode filtering must be done at the power supply output.

Output Signal Range

The LT1787's output signal is developed by summing the net currents through R_{G1} and R_{G2} into output resistor R_{OUT} . The pins V_{OUT} and V_{BIAS} may be connected in numerous configurations to interface with following circuitry in either single supply or split supply applications. Care must be used in connecting the output pins to preserve signal accuracy. Limitations on the signal swing at V_{OUT} are imposed by the negative supply, V_{EE} , and the input voltage V_S^+ . In the negative direction, internal circuit saturation with loss of accuracy occurs for $V_{OUT} < 70\text{mV}$

APPLICATIONS INFORMATION

with absolute minimum swing at 30mV above V_{EE} . V_{OUT} may swing positive to within 0.75V of V_{S^+} or a maximum of 35V, a limit set by internal junction breakdown. Within these constraints, an amplified, level shifted representation of the R_{SENSE} voltage is developed across R_{OUT} .

Split Supply Bipolar Output Swing

Figure 2 shows the LT1787 used with split power supplies. The V_{BIAS} pin is connected to ground, and the output signal appears at the V_{OUT} pin. Bidirectional input currents can be monitored with the output swinging positive for current flow from V_{S^+} and V_{S^-} . Input currents in the opposite direction cause V_{OUT} to swing below ground. Figure 2 shows an optional output capacitor connected from V_{OUT} to ground. This capacitor may be used to filter the output signal before it is processed by other circuitry. Figure 3 shows the voltage transfer function of the LT1787 used in this configuration.

Single Supply with Shifted V_{BIAS}

Figure 4 shows the LT1787 used in a single supply mode with the V_{BIAS} pin shifted positive using an external LT1634 voltage reference. The V_{OUT} output signal can swing above and below V_{BIAS} to allow monitoring of positive or negative currents through the sense resistor, as shown in Figure 5. The choice of reference voltage is not critical except for the precaution that adequate headroom must be provided for V_{OUT} to swing without saturating the internal circuitry. The component values shown in Figure 4 allow operation with V_S supplies as low as 3.1V.

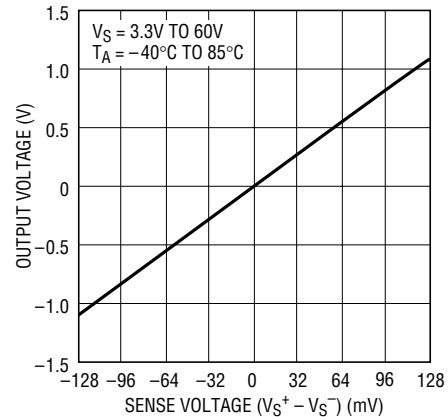

Figure 3. Split Supply Output Voltage

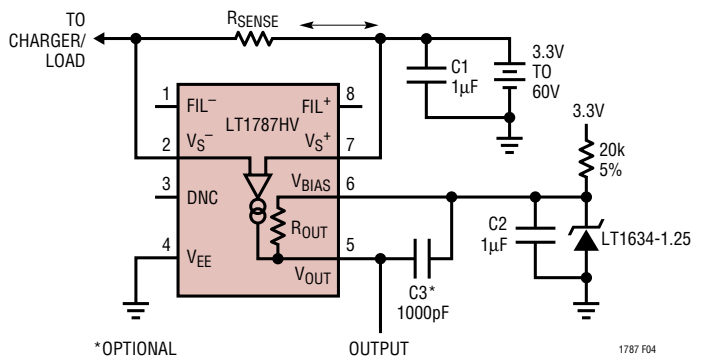

Figure 4. Charge/Discharge Current Monitor on Single Supply with $V_{BIAS} = 1.25V$

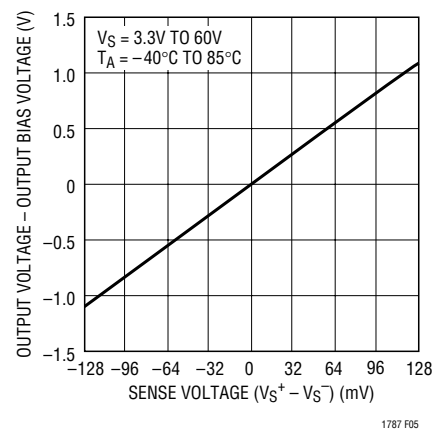

Figure 5. Single Supply Output Voltage with $V_{BIAS} = 1.25V$

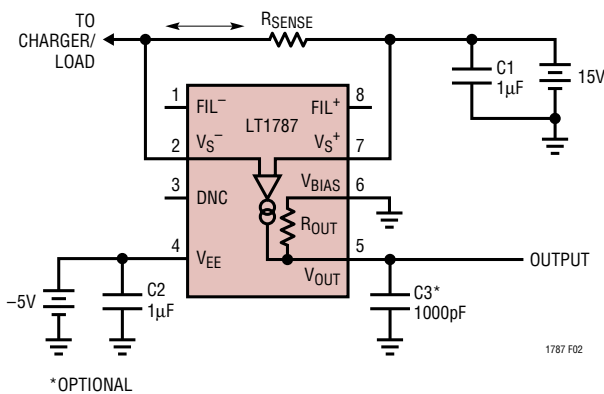

Figure 2. Split Supply Operation

APPLICATIONS INFORMATION

Operation with A/D Converter

Figure 6 shows the LT1787 operating with the LTC1286 A/D converter. This low cost circuit is capable of 12-bit resolution of unipolar currents. The $-IN$ pin of the A/D converter is biased at 1V by the resistor divider R1 and R2. This voltage increases as sense current increases, with the amplified sense voltage appearing between the A/D converters $-IN$ and $+IN$ terminals. The front page of the data sheet shows a similar circuit which uses a voltage reference for improved accuracy and signal range. The LTC1286 converter uses sequential sampling of its $-IN$ and $+IN$ inputs. Accuracy is degraded if the inputs move between sampling intervals. A filter capacitor from FIL^+ to FIL^- as well as a filter capacitor from V_{BIAS} to V_{OUT} may be necessary if the sensed current changes more than 1LSB within a conversion cycle.

Buffered Output Operation

Figure 7 shows the LT1787's outputs buffered by an operational amplifier configured as an I/V converter. This configuration is ideal for monitoring very low voltage supplies. The LT1787's V_{OUT} pin is held equal to the reference voltage appearing at the op amp's noninverting input. This allows monitoring V_S supplies as low as 2.5V. The op amp's output may swing from ground to its positive supply voltage. The low impedance output of the op amp may drive following circuitry more effectively than the high output impedance of the LT1787. The I/V converter configuration also works well with split supply voltages.

Single Supply Unidirectional Operation

Figure 8 shows the simplest connection in which the LT1787 may be used. The V_{BIAS} pin is connected to ground, and the V_{OUT} pin swings positive with increasing sense current. The LT1787's outputs can swing as low as 30mV as shown in Figure 9. Accuracy is sacrificed at small output levels, but this is not a limitation in protection circuit applications or where sensed currents do not vary greatly. Increased low level accuracy can be obtained by level shifting V_{BIAS} above ground. The level shifting may be done with resistor dividers, voltage references or a simple diode. Accuracy is ensured if the output signal is sensed differentially between V_{BIAS} and V_{OUT} .

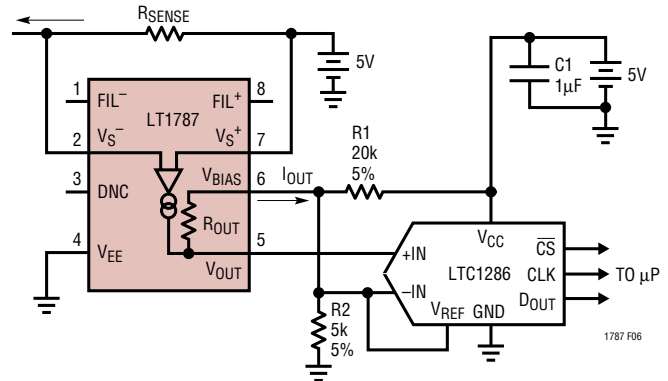

Figure 6. Unidirectional Output into A/D with Fixed Supply at V_S^+

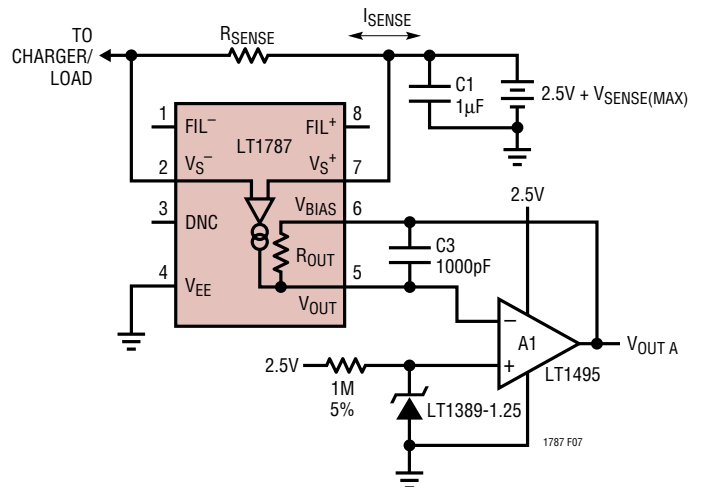

Figure 7. Single Supply 2.5V Bidirectional Operation with External Voltage Reference and I/V Converter

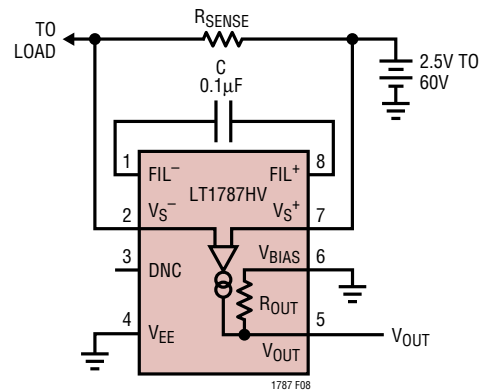

Figure 8. Unidirectional Current Sensing Mode

APPLICATIONS INFORMATION

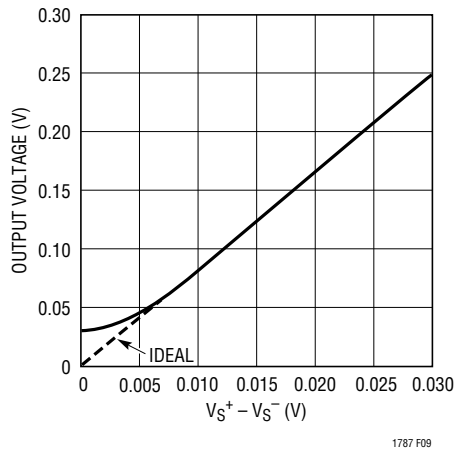

Figure 9. Expanded Scale of Unidirectional Output

Adjusting Gain Setting

The LT1787 may be used in all operating modes with an external resistor used in place of the internal 20k R_{OUT}

resistor. When an external resistor is used, leave the V_{BIAS} pin floating or connected to the V_{OUT} pin. This will remove the internal R_{OUT} from the circuit.

The voltage gain will be $g_m \cdot R_{OUT}$ where g_m is the LT1787's transconductance, 400 μ A/V typical. A nominal gain of 40 may be obtained with an external 100k resistor used in place of the internal 20k R_{OUT} :

$$A_V = g_m \cdot R_{OUT} = 400\mu\text{A/V} \cdot 100\text{k} = 40$$

The transconductance g_m is set by on-chip resistors on the LT1787. These resistors match well but have loose absolute tolerance. This will normally require that the external gain setting resistor be trimmed for initial accuracy. After trimming, the temperature stability of the g_m and therefore gain will be $-200\text{ppm}/^\circ\text{C}$.

The only limitations placed upon the resistor choice is care must be taken not to saturate the internal circuitry by violating the V_{OMAX} specification of $V_S + -0.75\text{V}$.

PACKAGE DESCRIPTION

Dimensions in inches (millimeters) unless otherwise noted.

**MS8 Package
8-Lead Plastic MSOP**
(LTC DWG # 05-08-1660)

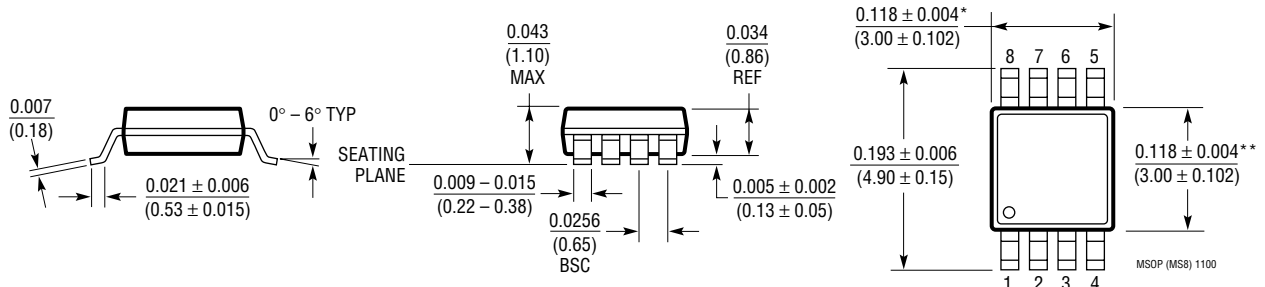

- * DIMENSION DOES NOT INCLUDE MOLD FLASH, PROTRUSIONS OR GATE BURRS. MOLD FLASH, PROTRUSIONS OR GATE BURRS SHALL NOT EXCEED 0.006^* (0.152mm) PER SIDE
- ** DIMENSION DOES NOT INCLUDE INTERLEAD FLASH OR PROTRUSIONS. INTERLEAD FLASH OR PROTRUSIONS SHALL NOT EXCEED 0.006^* (0.152mm) PER SIDE

PACKAGE DESCRIPTION Dimensions in inches (millimeters) unless otherwise noted.

S8 Package
8-Lead Plastic Small Outline (Narrow 0.150)
 (LTC DWG # 05-08-1610)

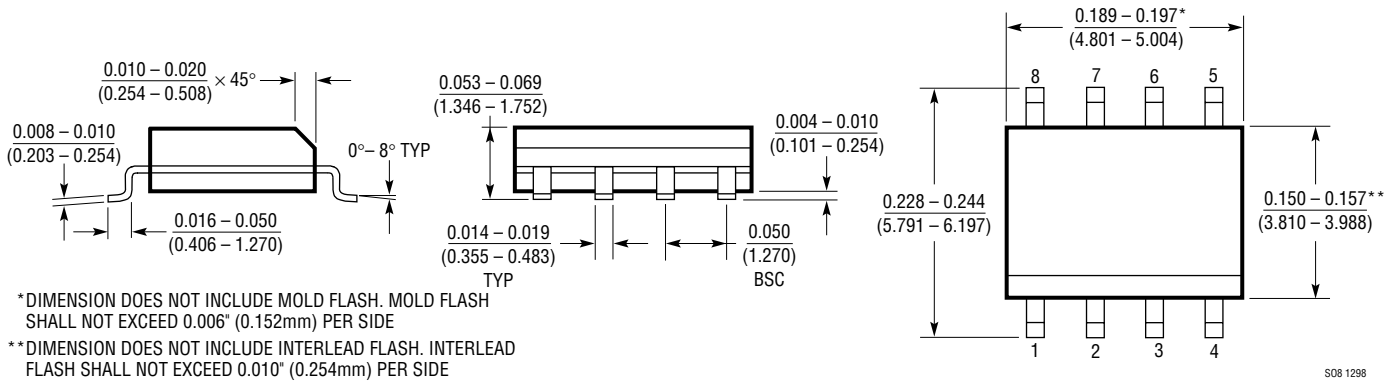

TYPICAL APPLICATION

Split or Single Supply Operation, Bidirectional Output into A/D

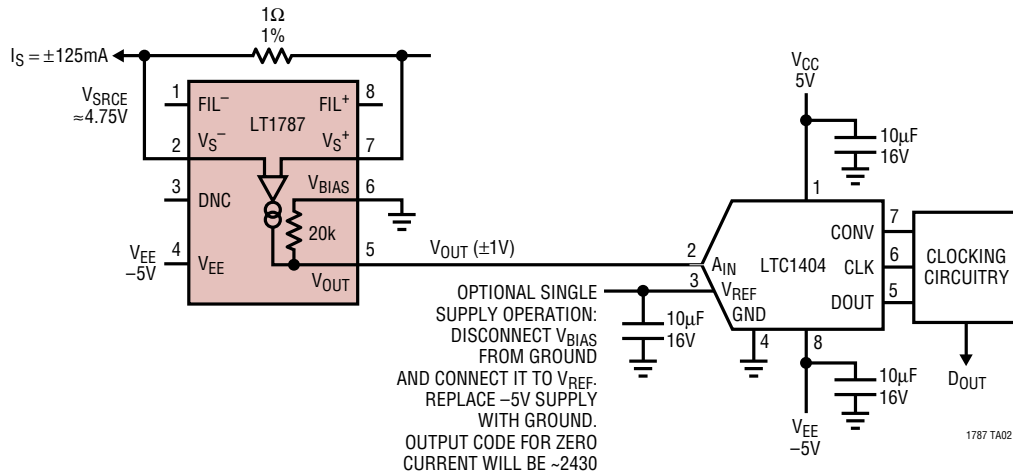

RELATED PARTS

| PART NUMBER | DESCRIPTION | COMMENTS |
|---------------|--|--|
| LTC1043 | Dual Precision Instrumentation Switched Capacitor Building Block | 120dB CMRR, 3V to 18V Operation |
| LT1490/LT1491 | Dual and Quad Micropower Rail-to-Rail Input and Output Op Amps | 50μA Amplifier, 2.7V to 40V Operation, Over-The-Top™ Inputs |
| LT1620/LT1621 | Rail-to-Rail Current Sense Amplifiers | Accurate Output Current Programming, Battery Charging to 32V |

Over-The-Top is a trademark of Linear Technology Corporation.