

## FEATURES

- **V<sub>IN</sub> Range: 2.6V to 4.4V**
- Step-Up Charge Pump Generates 5V
- Output Current: 10mA
- V<sub>IN</sub> to V<sub>OUT</sub> Direct Connection for 3V SIMs
- **Ultralow Power**  
   Operating Current: 14μA  
   Shutdown Current: <1μA
- **No Inductors**
- **Short-Circuit/Thermal Protected**
- Switching Frequency: 900kHz
- Soft-Start Limits Inrush Current at Turn-On
- Output Driven to Ground During Shutdown
- **Ultrasmall Application Circuit (<0.045in<sup>2</sup>)**
- **6-Lead SOT-23 Package**

## APPLICATIONS

- GSM Cellular Telephones
- PCS/DCS Cellular Telephones
- Portable POS Terminals

## DESCRIPTION

The LTC<sup>®</sup>1986 is a micropower charge pump DC/DC converter that provides power for either 3V or 5V GSM SIM cards. It operates in one of three modes: V<sub>OUT</sub> = 5V (5V mode), V<sub>OUT</sub> = V<sub>IN</sub> (3V mode) or shutdown. The input voltage range is 2.6V to 4.4V and the part can provide 10mA of output current. The LTC1986 allows V<sub>IN</sub> to drop as low as 2.6V by providing a boost feature in 3V mode. In 3V mode, V<sub>OUT</sub> is connected directly to V<sub>IN</sub> through a 2.5Ω switch until V<sub>IN</sub> drops below 2.85V. When V<sub>IN</sub> is below 2.85V, the part automatically boosts V<sub>OUT</sub> to maintain a regulated 2.9V output, thereby ensuring V<sub>OUT</sub> stays within the 3V SIM V<sub>CC</sub> specification.

Extremely low operating current (14μA typical with no load) and low external parts count make the part ideally suited for small, light load battery-powered applications. The total PCB area of the application circuit shown below is less than 0.045in<sup>2</sup>. Protection features include inrush current limiting, undervoltage lockout, short circuit and thermal overload protection. The LTC1986 is available in a 6-lead SOT-23 package.

 LTC and LT are registered trademarks of Linear Technology Corporation.

## TYPICAL APPLICATION

3V/5V SIM Power Supply

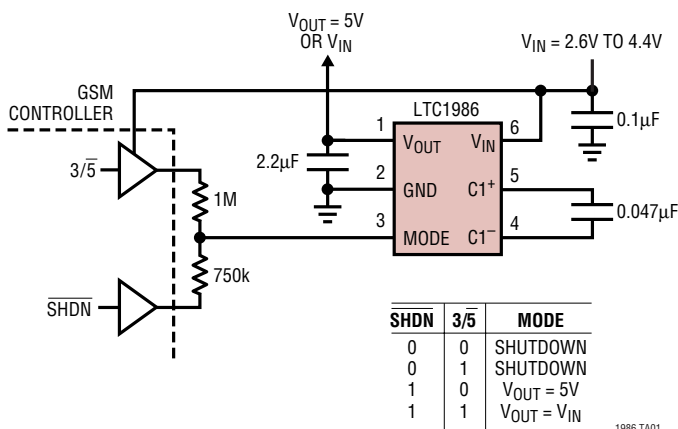

Output Voltage vs Input Voltage

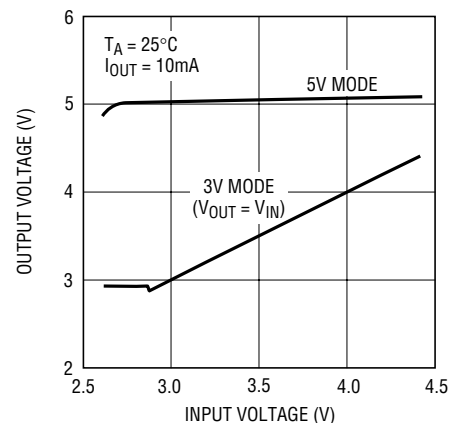

## ABSOLUTE MAXIMUM RATINGS

(Note 1)

$V_{IN}$ , $V_{OUT}$ to GND .....	-0.3V to 6V
All Other Pins to GND .....	-0.3V to 6V
$V_{OUT}$ Short-Circuit Duration .....	Indefinite
Operating Temperature Range (Note 2) .....	-40°C to 85°C
Storage Temperature Range .....	-65°C to 150°C
Lead Temperature (Soldering, 10 sec) .....	300°C

## PACKAGE/ORDER INFORMATION

	ORDER PART NUMBER
	LTC1986ES6
	S6 PART MARKING
	LTKX

Consult factory for Military grade parts.

## ELECTRICAL CHARACTERISTICS

The ● denotes specifications which apply over the full operating temperature range, otherwise specifications are  $T_A = 25^\circ\text{C}$ .  $V_{IN} = V_{MIN}$  to  $V_{MAX}$ ,  $MODE = V_{IN}$ ,  $C1 = 0.047\mu\text{F}$ ,  $C_{OUT} = 2.2\mu\text{F}$ , unless otherwise specified.

PARAMETER	CONDITIONS	MIN	TYP	MAX	UNITS	
$V_{IN}$ Operating Voltage	●	2.6		4.4	V	
$V_{OUT}$ Output Voltage	Shutdown Mode		0		V	
	3V Mode, $V_{IN} = 2.85\text{V}$ to $4.4\text{V}$ , $I_{OUT} \leq 10\text{mA}$		$V_{IN} - 0.025$		V	
	3V Mode, $V_{IN} < 2.85\text{V}$ , $I_{OUT} < 10\text{mA}$	●	2.75	2.9	3.05	V
	5V Mode, $V_{IN} < 2.7\text{V}$ , $I_{OUT} \leq 10\text{mA}$	●	4.55	5	5.25	V
	5V Mode, $V_{IN} = 2.7\text{V}$ to $4.4\text{V}$ , $I_{OUT} \leq 10\text{mA}$	●	4.75	5	5.25	V
$V_{IN}$ Operating Current	Shutdown Mode, $V_{MODE} = 0\text{V}$	●	0.001	1	$\mu\text{A}$	
	3V Mode, $I_{OUT} = 0\text{mA}$	●	10	25	$\mu\text{A}$	
	5V Mode, $I_{OUT} = 0\text{mA}$	●	14	30	$\mu\text{A}$	
$V_{IN}$ -to- $V_{OUT}$ ON Resistance	3V Mode, $V_{IN} = 3\text{V}$	●	2.5	5	$\Omega$	
$V_{OUT}$ Short-Circuit Current	3V or 5V Mode, $V_{OUT} = 0\text{V}$	●	100	200	mA	
$V_{OUT}$ Discharge Resistance		●	70	200	$\Omega$	
Switching Frequency	Oscillator Free-Running		900		kHz	
MODE Input Ranges	Shutdown Mode	●	0	$V_{IN}/2 - 0.1$	V	
	5V Mode	●	$V_{IN}/2 + 0.1$	$V_{IN} - 1.0$	V	
	3V Mode	●	$V_{IN} - 0.25$	$V_{IN}$	V	
MODE Input Current		●	-1	1	$\mu\text{A}$	
Undervoltage Lockout Threshold			1.4		V	

**Note 1:** Absolute Maximum Ratings are those values beyond which the life of a device may be impaired.

**Note 2:** The LTC1986 is guaranteed to meet performance specifications from 0°C to 70°C. Specifications over the -40°C to 85°C operating temperature range are assured by design, characterization and correlation with statistical process controls.

# TYPICAL PERFORMANCE CHARACTERISTICS

**Output Voltage vs Output Current (3V Mode)**

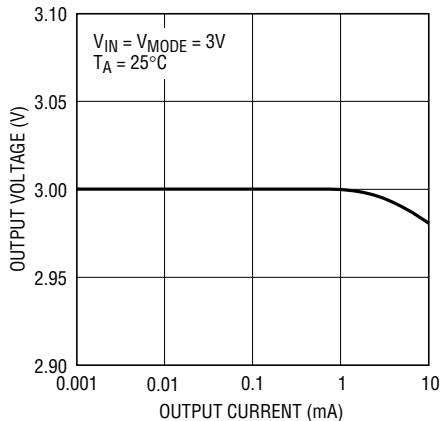

1986 G01

**Efficiency vs Input Voltage**

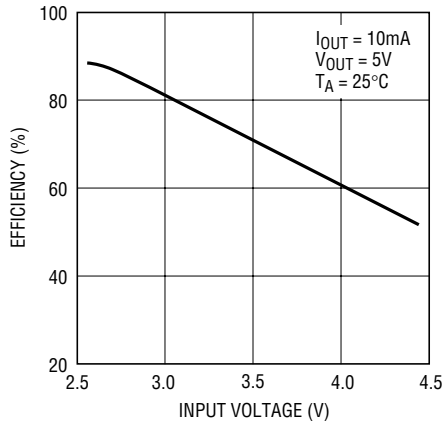

1986 G02

**Efficiency vs Output Current**

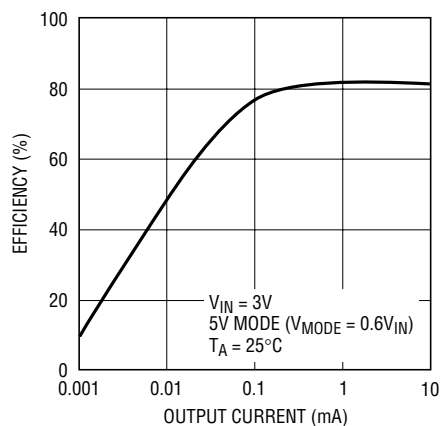

1986 G03

**Positive Supply Current vs Input Voltage**

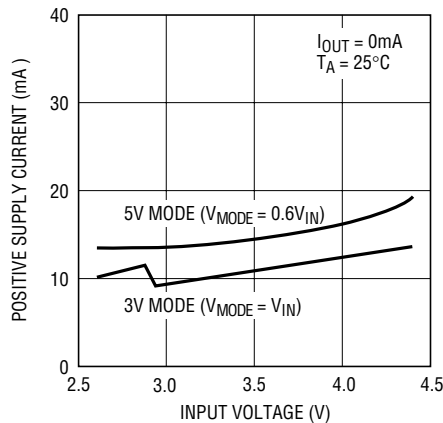

1986 G04

**Output Voltage Ripple (5V Mode)**

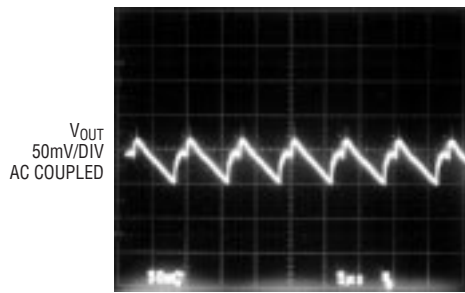

$V_{IN} = 3V$   
 $I_{OUT} = 10mA$   
 $T_A = 25^\circ C$

1986 G05

**Output Voltage vs V\_MODE Waveforms**

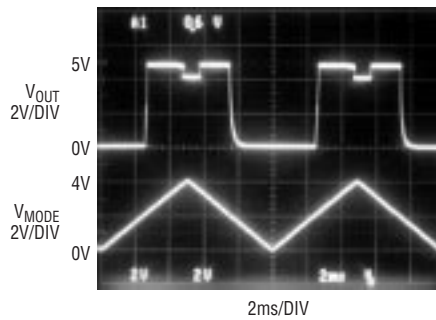

$V_{IN} = 4V$   
 $T_A = 25^\circ C$

1986 G06

## PIN FUNCTIONS

**V<sub>OUT</sub> (Pin 1):** Charge Pump Output. The V<sub>OUT</sub> voltage will depend on the MODE pin input voltage. V<sub>OUT</sub> = 0V in shutdown mode, V<sub>OUT</sub> = V<sub>IN</sub> in 3V mode and V<sub>OUT</sub> = 5V in 5V mode. The LTC1986 provides a 2.9V regulated output when the part is in 3V mode and the V<sub>IN</sub> voltage is below 2.85V. This feature allows the input voltage to be below the minimum voltage specification for 3V SIM cards without violating the SIM V<sub>CC</sub> specification. Bypass the V<sub>OUT</sub> pin with a  $\geq 2.2\mu\text{F}$  low ESR capacitor to ground.

**GND (Pin 2):** Ground. Connect to a ground plane for best performance.

**MODE (Pin 3):** MODE Input Pin. The voltage on this pin determines the operating mode of the LTC1986. It operates in either shutdown mode, 3V mode or 5V mode depending on the MODE pin voltage with respect to V<sub>IN</sub>.

The three different modes can be realized by using two external resistors as shown in the typical application circuit. If  $V_{\text{MODE}} < V_{\text{IN}}/2 - 0.1\text{V}$ , the part is in shutdown mode. If  $V_{\text{IN}}/2 + 0.1\text{V} < V_{\text{MODE}} < V_{\text{IN}} - 1\text{V}$ , the part is in 5V mode. If  $V_{\text{IN}} - 0.25\text{V} < V_{\text{MODE}}$ , the part is in 3V mode. To achieve the lowest possible shutdown current, the MODE pin should be pulled to 0V, i.e., both the SHDN and 3/5 signals from the controller should be pulled low.

**C1<sup>-</sup> (Pin 4):** Charge Pump Flying Capacitor Negative Terminal.

**C1<sup>+</sup> (Pin 5):** Charge Pump Flying Capacitor Positive Terminal.

**V<sub>IN</sub> (Pin 6):** Input Supply Voltage. Bypass V<sub>IN</sub> with a  $\geq 0.1\mu\text{F}$  low ESR capacitor to ground.

## SIMPLIFIED BLOCK DIAGRAM

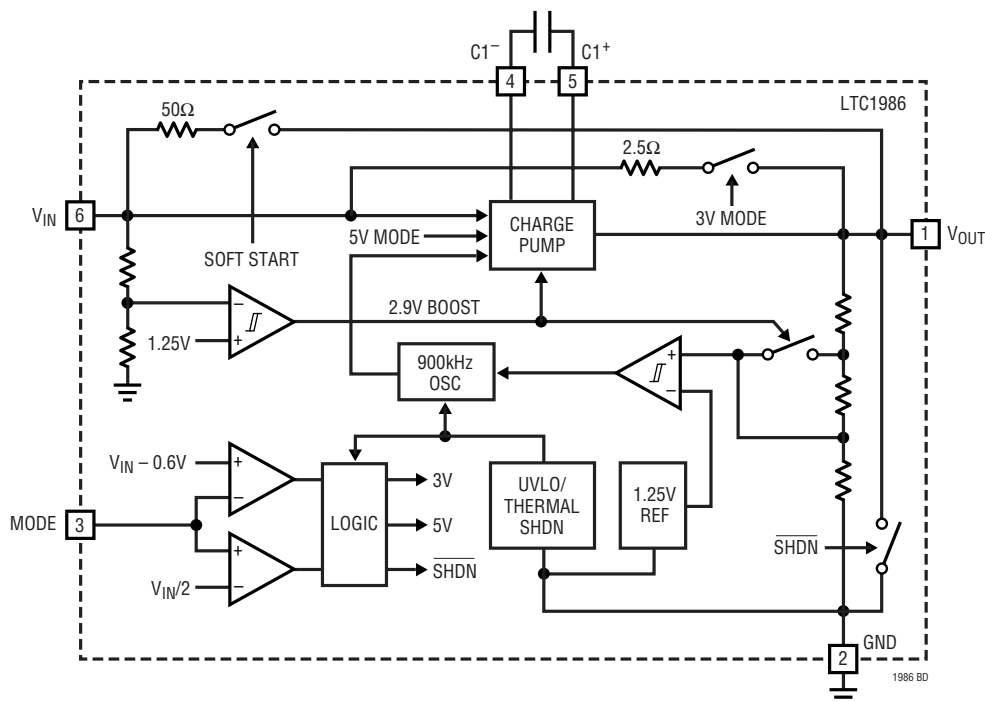

## APPLICATIONS INFORMATION

### Operation

The LTC1986 is a charge pump DC/DC converter designed specifically to supply  $V_{CC}$  power for either 3V or 5V SIM cards. The part can operate in one of three modes: a low power shutdown mode which disconnects  $V_{IN}$  from  $V_{OUT}$  and actively pulls down the  $V_{OUT}$  supply, 3V mode which provides a direct connection between  $V_{IN}$  and  $V_{OUT}$  for powering 3V SIM cards, and 5V mode which provides a regulated 5V output for powering 5V SIM cards. In 5V mode, regulation is achieved by sensing the output voltage through a resistor divider and enabling the charge pump as needed to maintain regulation.

When the charge pump is enabled, a 2-phase nonoverlapping clock controls the internal charge pump switches. Flying capacitor C1 is charged to  $V_{IN}$  on phase one of the clock. On phase two of the clock, C1 is stacked in series with  $V_{IN}$  and connected to  $V_{OUT}$  through an internal switch. This sequence of charging and discharging the flying capacitor occurs at a free-running frequency of 900kHz (typ) and continues until the divided output voltage reaches the upper trip point of the comparator. Once the output is in regulation, the charge pump is disabled. This method of bursting the charge pump on and off enables the LTC1986 to achieve high efficiency at extremely low output loads.

### Mode Selection

The operating mode is determined by the voltage applied to the MODE pin. The MODE pin has three voltage thresholds—all of which are referenced to  $V_{IN}$ :

$$\begin{aligned} \text{Shutdown Mode} &\Rightarrow V_{\text{MODE}} < V_{\text{IN}}/2 - 0.1\text{V} \\ \text{5V Mode} &\Rightarrow V_{\text{IN}}/2 + 0.1\text{V} < V_{\text{MODE}} < V_{\text{IN}} - 1\text{V} \\ \text{3V Mode} &\Rightarrow V_{\text{IN}} - 0.25\text{V} < V_{\text{MODE}} \end{aligned}$$

For example, if  $V_{IN} = 3\text{V}$ , then the following table applies:

$V_{\text{MODE}}$	OPERATING MODE
0V to 1.4V	Shutdown Mode
1.6V to 2V	5V Mode
2.75V to 3V	3V Mode ( $V_{\text{OUT}} = V_{\text{IN}}$ )

The three modes can be selected using two totem pole digital outputs and two external resistors as shown in Figure 1.

Shutdown mode disconnects  $V_{IN}$  from  $V_{OUT}$  and enables an internal pull-down device which forces  $V_{OUT}$  to GND. To achieve the lowest possible quiescent current in shutdown mode, the voltage on the MODE pin should be pulled below 0.4V. 3V mode connects  $V_{OUT}$  to  $V_{IN}$  through a 2.5 $\Omega$  internal switch. The LTC1986 has the additional capability of boosting  $V_{OUT}$  to a regulated 2.9V in 3V mode when the input voltage drops below 2.85V. This ensures that the 3V SIM  $V_{CC}$  specification is not violated if  $V_{IN}$  drops below 2.7V during transients or low battery conditions.

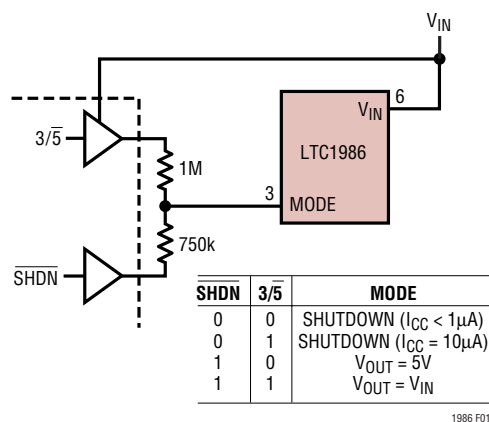

Figure 1

### Capacitor Selection

For best performance, it is recommended that low ESR capacitors be used for both  $C_{\text{IN}}$  and  $C_{\text{OUT}}$  to reduce noise and ripple. The  $C_{\text{IN}}$  and  $C_{\text{OUT}}$  capacitors should be either ceramic or tantalum. Ceramic capacitors will provide the smallest size for a given capacitance. If the input source impedance is very low ( $< 0.5\Omega$ ),  $C_{\text{IN}}$  may not be needed. For best performance,  $C_{\text{OUT}}$  should be 2.2 $\mu\text{F}$  or greater. Ceramic capacitors are also recommended for the flying capacitor C1 with values between 0.047 $\mu\text{F}$  and 0.22 $\mu\text{F}$ . If a small value output capacitor (3.3 $\mu\text{F}$  or less) is used, a small flying capacitor should also be used to prevent high output ripple in 5V mode. The recommended capacitor values to minimize board space and cost are:  $C_{\text{IN}} = 0.1\mu\text{F}$ ,  $C_1 = 0.047\mu\text{F}$  and  $C_{\text{OUT}} = 2.2\mu\text{F}$  (ceramic).

## APPLICATIONS INFORMATION

### Output Ripple

Normal 5V mode operation produces voltage ripple on the  $V_{OUT}$  pin. Output voltage ripple is required for regulation. Low frequency ripple exists due to the hysteresis in the sense comparator and propagation delays in the charge pump enable/disable circuits. High frequency ripple is also present mainly from the ESR (equivalent series resistance) in the output capacitor. Typical output ripple with  $V_{IN} = 3V$  under maximum load is  $75mV_{P-P}$  with a low ESR  $2.2\mu F$  output capacitor and a  $0.047\mu F$  C1 capacitor. For applications requiring  $V_{IN}$  to exceed 3.3V or for applications requiring  $<75mV$  of peak-to-peak ripple, a  $3.3\mu F$  to  $10\mu F$   $C_{OUT}$  capacitor is recommended. Slight further decreases in output ripple can be achieved by using  $C_{OUT}$  capacitors larger than  $10\mu F$ .

### Protection Features

The LTC1986 provides several protection features. Undervoltage lockout prevents any current from flowing between  $V_{IN}$  and  $V_{OUT}$  until the  $V_{IN}$  voltage exceeds 1.4V (typ). This prevents undesirable glitches during power-up. The parts also limit inrush current during power-up to under 200mA regardless of  $V_{IN}$  voltage, operating mode and output load by disabling the main direct connect switch (3V mode) or the charge pump (5V mode) and enabling a  $50\Omega$  series switch between  $V_{IN}$  and  $V_{OUT}$  until  $V_{OUT}$  reaches  $V_{IN}/2$ . The parts are also short-circuit protected and can survive an indefinite short from  $V_{OUT}$  to GND regardless of operating mode or input voltage. In the event of thermal overload, the parts will enter thermal shutdown if the junction temperature exceeds  $165^{\circ}C$  and return to normal operation once the junction temperature drops to  $150^{\circ}C$ .

## PACKAGE DESCRIPTION

Dimensions in inches (millimeters) unless otherwise noted.

### S6 Package 6-Lead Plastic SOT-23 (LTC DWG # 05-08-1634)

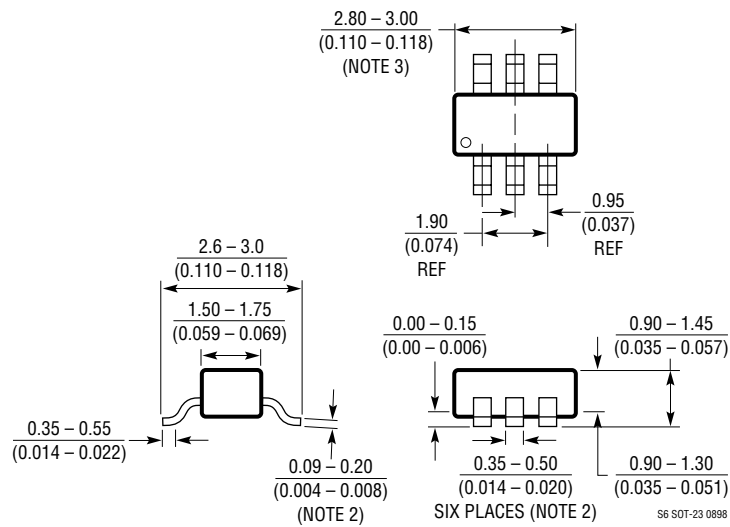

**NOTE:**

1. DIMENSIONS ARE IN MILLIMETERS
2. DIMENSIONS ARE INCLUSIVE OF PLATING
3. DIMENSIONS ARE EXCLUSIVE OF MOLD FLASH AND METAL BURR
4. MOLD FLASH SHALL NOT EXCEED 0.254mm
5. PACKAGE EIAJ REFERENCE IS SC-74A (EIAJ)

# TYPICAL APPLICATION

3V/5V SIM Power Supply

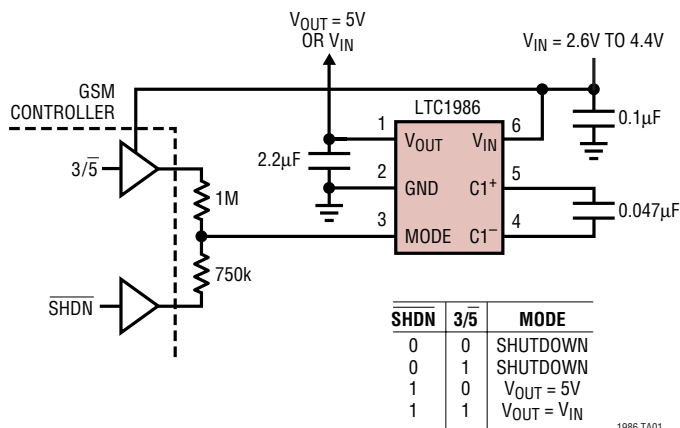

## RELATED PARTS

PART NUMBER	DESCRIPTION	COMMENTS
LTC1503	High Efficiency Step-Down Charge Pump	V <sub>IN</sub> = 2.4V to 6V, 100mA Output Current
LTC1517	Micropower Charge Pump in 5-Pin SOT-23	I <sub>CC</sub> = 6µA, Short-Circuit/Thermal Protected
LTC1555	SIM Power Supply and Level Translator	V <sub>IN</sub> = 2.7V to 10V, 10kV ESD on SIM Contact Pins
LT1615	Micropower Step-Up DC/DC Converter in SOT-23	V <sub>IN</sub> = 1.2V to 15V; 350mA, 36V Switch
LT1682	Charge Pump Plus Low Noise LDO Regulator in MSOP	50mA Output Current; 60µV <sub>RMS</sub> Output Noise
LTC1754-5	5V Charge Pump with Shutdown in SOT-23	50mA Output Current, I <sub>CC</sub> = 13µA
LTC1754-3.3	3.3V Charge Pump with Shutdown in SOT-23	V <sub>IN</sub> = 2V to 4.4V; I <sub>OUT</sub> = 40mA; Ripple = 23mV <sub>P-P</sub>
LT1761	Low Noise, 100mA Micropower LDO Regulator	I <sub>Q</sub> = 20µA, 20µV <sub>RMS</sub> Noise, SOT-23 Package
LTC1755	Smart Card Power Supply and Level Translator	ISO 7816-3 and EMV Compliant