

DUAL RETRIGGERABLE MONOSTABLE MULTIVIBRATOR

- HIGH SPEED
 $t_{PD} = 25 \text{ ns}$ (TYP) at $V_{CC} = 5V$
- LOW POWER DISSIPATION
 STANDBY STATE $I_{CC} = 4 \mu A$ (MAX.) AT $T_A = 25^\circ C$
 ACTIVE STATE $I_{CC} = 200 \mu A$ (TYP.) AT $V_{CC} = 5V$
- HIGH NOISE IMMUNITY
 $V_{NIH} = V_{NIL} = 28 \% V_{CC}$ (MIN.)
- OUTPUT DRIVE CAPABILITY
 10 LSTTL LOADS
- SYMMETRICAL OUTPUT IMPEDANCE
 $I_{OH} = I_{OL} = 4 \text{ mA}$ (MIN.)
- BALANCED PROPAGATION DELAYS
 $t_{PLH} = t_{PHL}$
- WIDE OPERATING VOLTAGE RANGE
 $V_{CC} \text{ (OPR)} = 2 \text{ V TO } 6 \text{ V}$
- WIDE OUTPUT PULSE WIDTH RANGE
 $t_{WOUT} = 120 \text{ ns} \sim 60 \text{ s}$ OVER AT $V_{CC} = 4.5 \text{ V}$
- PIN AND FUNCTION COMPATIBLE WITH
 54/74LS123

DESCRIPTION

The M54/74HC123 is a high speed CMOS MONOSTABLE multivibrator fabricated with silicon gate C^2MOS technology. It achieves the high speed operation similar to equivalent LSTTL while maintaining the CMOS low power dissipation. There are two trigger inputs, \bar{A} INPUT (negative edge) and \bar{B} INPUT (positive edge). These inputs are valid for slow rising/falling signals, ($t_r = t_f = 1 \text{ sec}$). The device may also be triggered by using the CLR input (positive-edge) because of the Schmitt-trigger input ; after triggering the output maintains the MONOSTABLE state for the time period determined by the external resistor R_x and capacitor C_x . When $C_x \geq 10 \text{ nF}$ and $R_x \geq 10 \text{ K}\Omega$, the output pulse width value is approssimatively given by the formula: $t_{w(out)} = K \bullet C_x \bullet R_x$.

Two different pulse width constant are available:
 $K \approx 0.45$ for HC123 $K \approx 1$ for HC123A.
 Taking CLR low breaks this MONOSTABLE STATE. If the next trigger pulse occurs during the MONOSTABLE period it makes the MONOSTABLE period longer. Limit for values of C_x and R_x :
 C_x : NO LIMIT
 R_x : $V_{CC} < 3.0 \text{ V}$ $5 \text{ K}\Omega$ to $1 \text{ M}\Omega$
 $V_{CC} \geq 3.0 \text{ V}$ $1 \text{ K}\Omega$ to $1 \text{ M}\Omega$
 All inputs are equipped with protection circuits

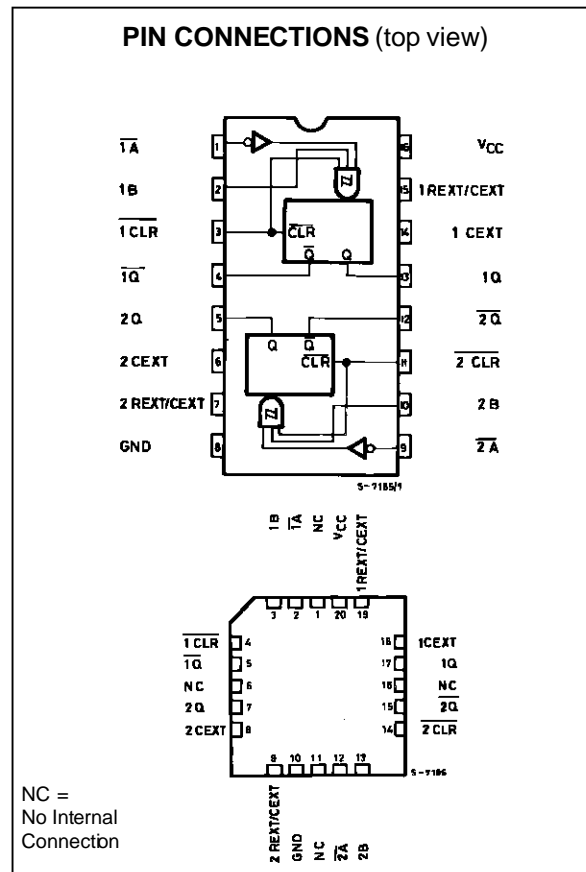
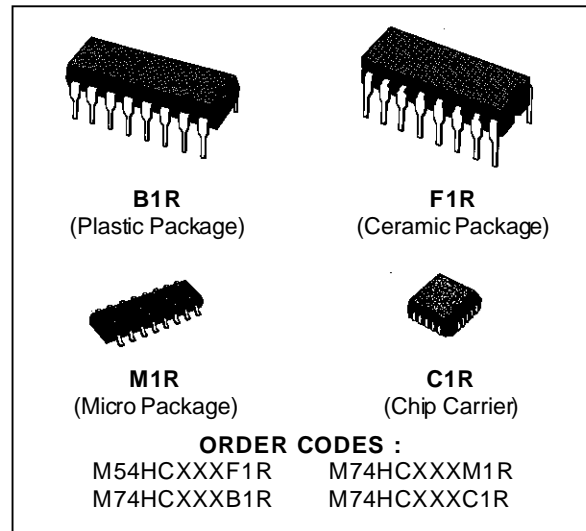

SYSTEM DIAGRAM

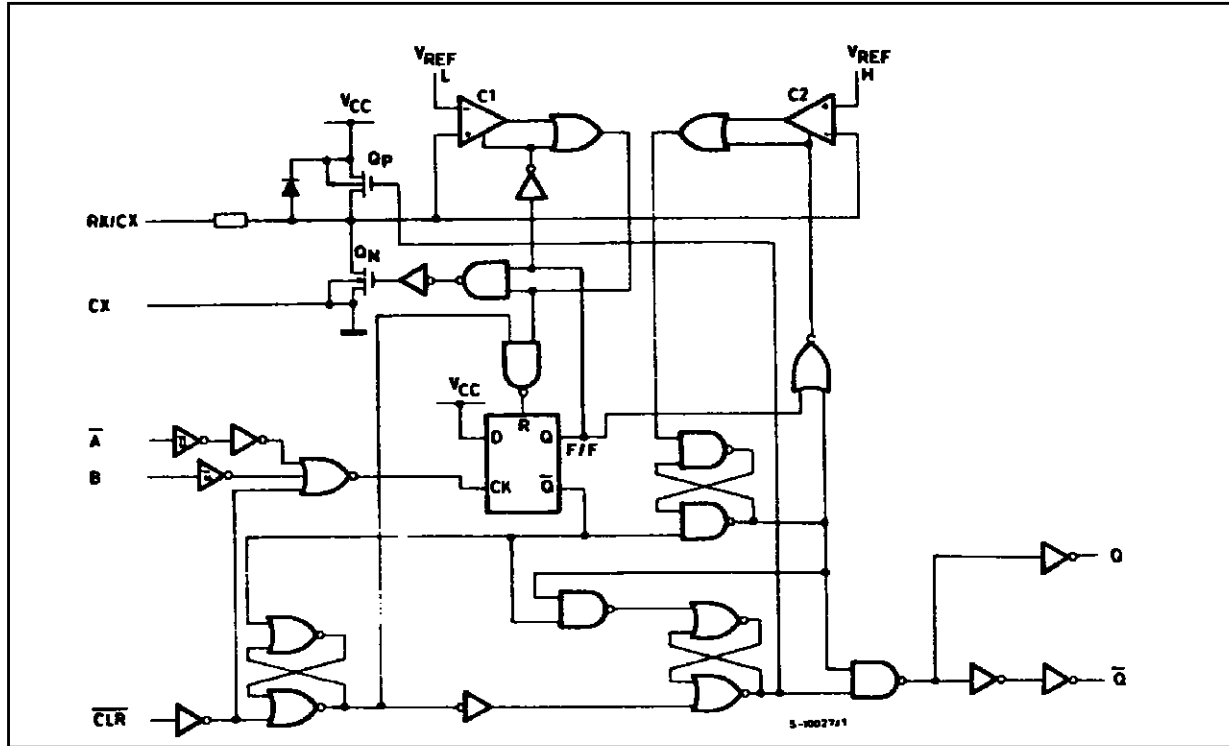

TIMING CHART

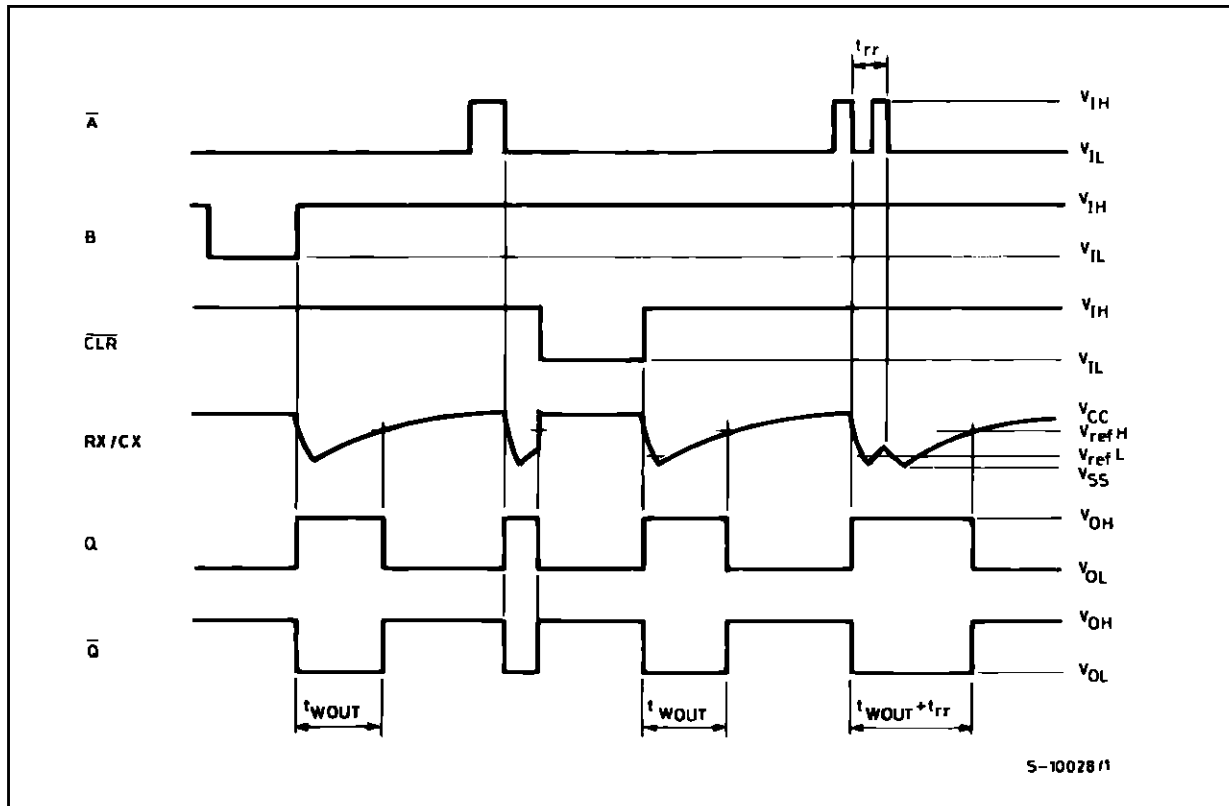

BLOCK DIAGRAM

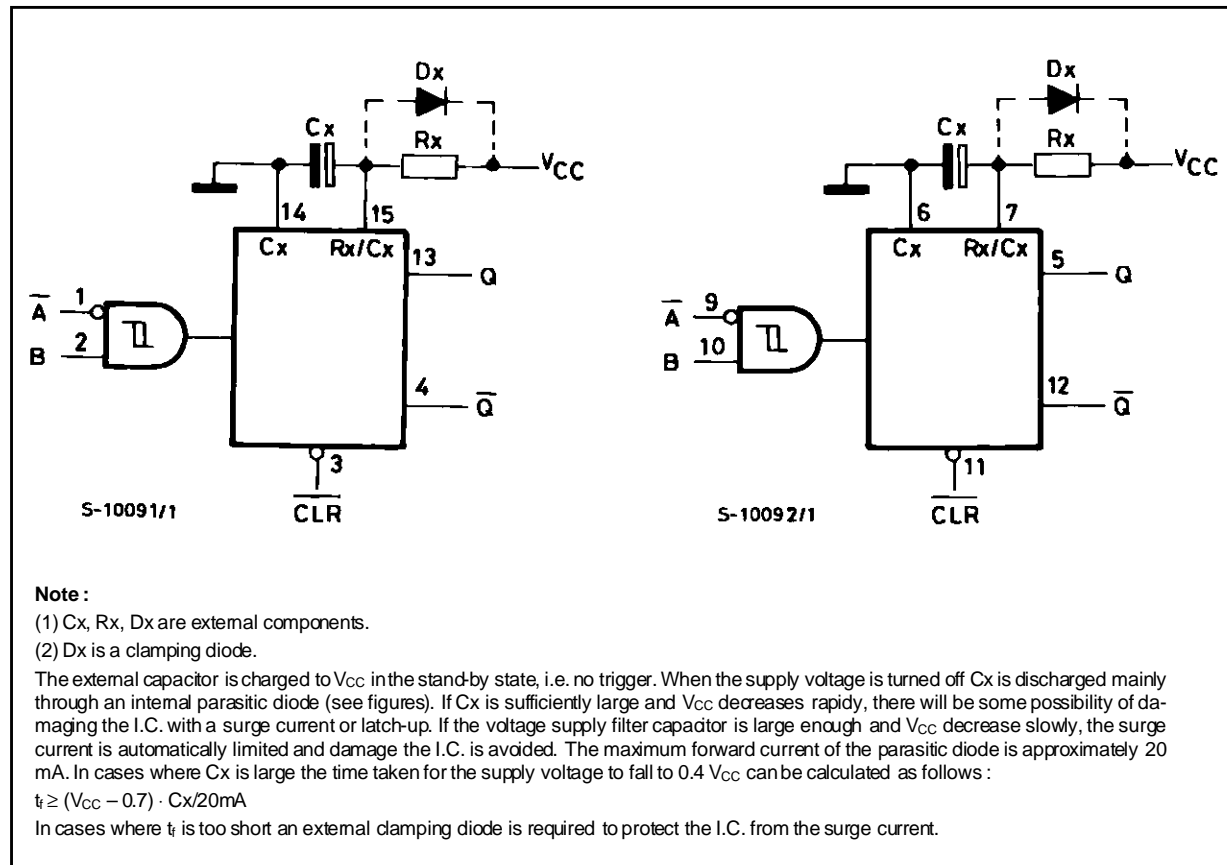

FUNCTIONAL DESCRIPTION

STAND-BY STATE

The external capacitor, Cx, is fully charged to V_{CC} in the stand-by state. Hence, before triggering, transistor Qp and Qn (connected to the Rx/Cx node) are both turned-off. The two comparators that control the timing and the two reference voltage sources stop operating. The total supply current is therefore only leakage current.

TRIGGER OPERATION

Triggering occurs when :

- 1 st) A is "low" and B has a falling edge ;
- 2 nd) B is "high" and A has a rising edge ;
- 3 rd) A is low and B is high and C1 has a rising edge.

After the multivibrator has been retriggered comparator C1 and C2 start operating and Qn is turned on. Cx then discharges through Qn. The voltage at the node R/C external falls.

When it reaches V_{REFL} the output of comparator C1 becomes low. This in turn resets the flip-flop and Qn is turned off.

At this point C1 stops functioning but C2 continues to operate.

The voltage at R/C external begins to rise with a time constant set by the external components Rx, Cx.

Triggering the multivibrator causes Q to go high after internal delay due to the flip-flop and the gate. Q remains high until the voltage at R/C external rises again to V_{REFH}. At this point C2 output goes low and Q goes low. C2 stop operating. That means that after triggering when the voltage R/C external returns to V_{REFH} the multivibrator has returned to its MONOSTABLE STATE. In the case where Rx · Cx are large enough and the discharge time of the capacitor and the delay time in the I.C. can be ignored, the width of the output pulse t_w (out) is as follows :

$$t_{w(OUT)} = 0.46 Cx \cdot Rx \text{ (HC123)}$$

$$t_{w(OUT)} = Cx \cdot Rx \text{ (HC123A)}$$

FUNCTIONAL DESCRIPTION (continued)

RE-TRIGGERED OPERATION

When a second trigger pulse follows the first its effect will depend on the state of the multivibrator. If the capacitor Cx is being charged the voltage level of R/C external falls to Vrefl again and Q remains high i.e. the retrigger pulse arrives in a time shorter than the period $R_x \cdot C_x$ seconds, the capacitor charging time constant. If the second trigger pulse is very close to the initial trigger pulse it is ineffective ; i.e. the second trigger must arrive in the capacitor discharge cycle to be ineffective; Hence the mini-

imum time for a second trigger to be effective depends on Vcc and Cx.

RESET OPERATION

CL is normally high. If CL is low, the trigger is not effective because Q output goes low and trigger control flip-flop is reset.

Also transistor Op is turned on and Cx is charged quickly to Vcc. This means if CL input goes low, the IC becomes waiting state both in operating and non operating state.

TRUTH TABLE

INPUTS			OUTPUTS		NOTE
\bar{A}	B	\bar{CL}	Q	\bar{Q}	
	H	H			OUTPUT ENABLE
X	L	H	L	H	INHIBIT
H	X	H	L	H	INHIBIT
L		H			OUTPUT ENABLE
L	H				OUTPUT ENABLE
X	X	L	L	H	INHIBIT

X: Don't Care Z: High Impedance

INPUT AND OUTPUT EQUIVALENT CIRCUIT

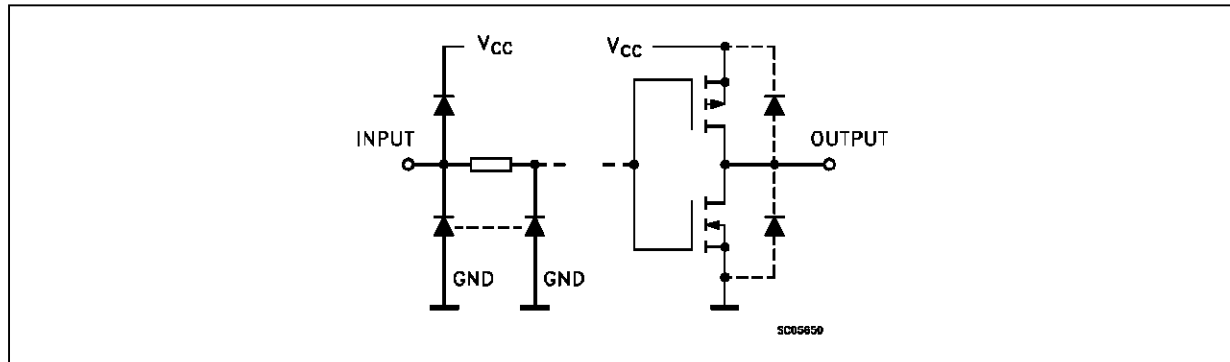

PIN DESCRIPTION

PIN No	SYMBOL	NAME AND FUNCTION
1, 9	1A, 2A	Trigger Inputs (Negative Edge Triggered)
2, 10	1B, 2B	Trigger Inputs (Positive Edge Triggered)
3, 11	1CLR, 2CLR	Direct Reset LOW and Trigger Action at Positive Edge
4, 12	1Q, 2Q	Outputs (Active LOW)
7	2REXT/CEXT	External Resistor Capacitor Connection
13, 5	1Q, 2Q	Outputs (Active HIGH)
14, 6	1CEXT, 2CEXT	External Capacitor Connection
15	1REXT/CEXT	External Resistor Capacitor Connection
8	GND	Ground (0V)
16	VCC	Positive Supply Voltage

IEC LOGIC SYMBOL

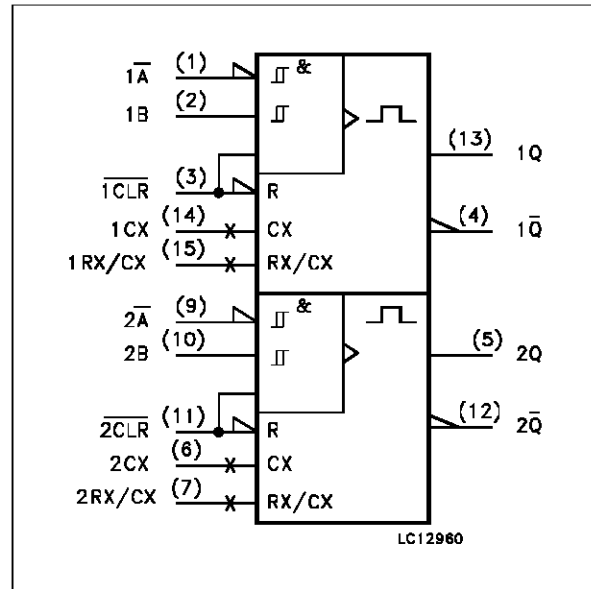

ABSOLUTE MAXIMUM RATING

Symbol	Parameter	Value	Unit
V _{CC}	Supply Voltage	-0.5 to +7	V
V _I	DC Input Voltage	-0.5 to V _{CC} + 0.5	V
V _O	DC Output Voltage	-0.5 to V _{CC} + 0.5	V
I _{IK}	DC Input Diode Current	± 20	mA
I _{OK}	DC Output Diode Current	± 20	mA
I _O	DC Output Source Sink Current Per Output Pin	± 25	mA
I _{CC} or I _{GND}	DC V _{CC} or Ground Current	± 50	mA
P _D	Power Dissipation	500 (*)	mW
T _{stg}	Storage Temperature	-65 to +150	°C
T _L	Lead Temperature (10 sec)	300	°C

Absolute Maximum Ratings are those values beyond which damage to the device may occur. Functional operation under these condition is not implied.
 (*) 500 mW: ± 65 °C derate to 300 mW by 10mW/°C: 65 °C to 85 °C

M54/M74HC123/123A

RECOMMENDED OPERATING CONDITIONS

Symbol	Parameter	Value	Unit	
V _{CC}	Supply Voltage	2 to 6	V	
V _I	Input Voltage	0 to V _{CC}	V	
V _O	Output Voltage	0 to V _{CC}	V	
T _{op}	Operating Temperature: M54HC Series M74HC Series	-55 to +125 -40 to +85	°C °C	
t _r , t _f	Input Rise and Fall Time	0 to 1000 0 to 500 0 to 400	ns	
C _X	External Capacitor	NO LIMITATION	pF	
R _X	External Resistor	V _{CC} < 3 V	5K to 1M	Ω
		V _{CC} ≥ 3 V	1K to 1M	

(*) The maximum allowable values of C_x and R_x are a function of leakage of capacitor C_x, the leakage of device and leakage due to the board layout and surface resistance. Susceptibility to externally induced noise may occur for R_x > 1MΩ

DC SPECIFICATIONS

Symbol	Parameter	Test Conditions		Value						Unit	
		V _{CC} (V)		T _A = 25 °C 54HC and 74HC			-40 to 85 °C 74HC		-55 to 125 °C 54HC		
				Min.	Typ.	Max.	Min.	Max.	Min.		Max.
V _{IH}	High Level Input Voltage	2.0		1.5			1.5		1.5		V
		4.5		3.15			3.15		3.15		
		6.0		4.2			4.2		4.2		
V _{IL}	Low Level Input Voltage	2.0				0.5		0.5		0.5	V
		4.5				1.35		1.35		1.35	
		6.0				1.8		1.8		1.8	
V _{OH}	High Level Output Voltage	2.0	V _I = V _{IH} or V _{IL} I _O = -20 μA	1.9	2.0		1.9		1.9		V
		4.5		4.4	4.5		4.4		4.4		
		6.0		5.9	6.0		5.9		5.9		
		4.5	I _O = -4.0 mA	4.18	4.31		4.13		4.10		
		6.0		I _O = -5.2 mA	5.68	5.8		5.63		5.60	
V _{OL}	Low Level Output Voltage	2.0	V _I = V _{IH} or V _{IL} I _O = 20 μA		0.0	0.1		0.1		0.1	V
		4.5			0.0	0.1		0.1		0.1	
		6.0			0.0	0.1		0.1		0.1	
		4.5	I _O = 4.0 mA		0.17	0.26		0.33		0.40	
		6.0		I _O = 5.2 mA		0.18	0.26		0.33		
I _I	Input Leakage Current	6.0	V _I = V _{CC} or GND			±0.1		±1		±1	μA
I _I	R/C Terminal Off State Current	6.0	V _I = V _{CC} or GND			±0.1		±1		±1	μA
I _{CC}	Quiescent Supply Current	6.0	V _I = V _{CC} or GND			4		40		80	μA
I _{CC} '	Active State Supply Current (1)	2.0	V _I = V _{CC} or GND Pin 7 or 15 V _{IN} = V _{CC} /2		45	200		260		320	μA
		4.5			500	600		780		960	μA
		6.0			0.7	1		1.3		1.6	mA

(1): Per Circuit

AC ELECTRICAL CHARACTERISTICS (C_L = 50 pF, Input t_r = t_f = 6 ns)

Symbol	Parameter	Test Conditions		Value						Unit		
		V _{CC} (V)		T _A = 25 °C 54HC and 74HC			-40 to 85 °C 74HC		-55 to 125 °C 54HC			
				Min.	Typ.	Max.	Min.	Max.	Min.		Max.	
t _{TLH} t _{THL}	Output Transition Time	2.0			30	75		95		110	ns	
		4.5			8	15		19		22		
		6.0			7	13		16		19		
t _{PLH} t _{PHL}	Propagation Delay Time (A, B - Q, Q̄)	2.0			102	210		265		315	ns	
		4.5			29	42		53		63		
		6.0			22	36		45		54		
t _{PLH} t _{PHL}	Propagation Delay Time (CLR TRIGGER - Q, Q̄)	2.0			102	235		295		355	ns	
		4.5			31	47		59		71		
		6.0			23	40		50		60		
t _{PLH} t _{PHL}	Propagation Delay Time (CLR - Q, Q̄)	2.0			68	160		200		240	ns	
		4.5			20	32		40		48		
		6.0			16	27		34		41		
tw _{OUT}	Output Pulse Width (for HC123)	2.0	C _X = 100 pF R _X = 10 KΩ		1.4						μs	
		4.5			1.2							
		6.0			1.1							
		2.0	C _X = 0.1 μF R _X = 100 KΩ		4.6							ms
		4.5			4.4							
		6.0			4.3							
tw _{OUT}	Output Pulse Width (for HC123A)	2.0	C _X = 100 pF R _X = 10 KΩ		1.9						μs	
		4.5			1.6							
		6.0			1.5							
		2.0	C _X = 0.1 μF R _X = 100 KΩ		9.8							ms
		4.5			9.5							
		6.0			9.4							
Δtw _{OUT}	Output Pulse Width Error Between Circuits in Same Package				±1						%	
t _{w(H)} t _{w(L)}	Minimum Pulse Width	2.0				75		95		110	ns	
		4.5				15		19		22		
		6.0				13		16		19		
t _{w(L)}	Minimum Pulse Width (CLR)	2.0				75		95		110	ns	
		4.5				15		19		22		
		6.0				13		16		19		
t _{rr}	Minimum Retrigger Time	2.0	C _X = 100 pF R _X = 1 KΩ		325						ns	
		4.5			108							
		6.0			78							
		2.0	C _X = 0.1 μF R _X = 100 KΩ		5							μs
		4.5			1.4							
		6.0			1.2							
C _{IN}	Input Capacitance				5	10		10		10	pF	
C _{PD} (*)	Power Dissipation Capacitance				162						pF	

(*) C_{PD} is defined as the value of the IC's internal equivalent capacitance which is calculated from the operating current consumption without load. (Refer to Test Circuit). Average operating current can be obtained by the following equation. I_{CC(OPR)} = C_{PD} • V_{CC} • f_{IN} + I_{CC'} Duty/100 + I_C/2 (per monostable) (I_{CC'}: Active Supply Current) (Duty:%)

M54/M74HC123/123A

Output Pulse Width Constant Characteristics (for HC123)

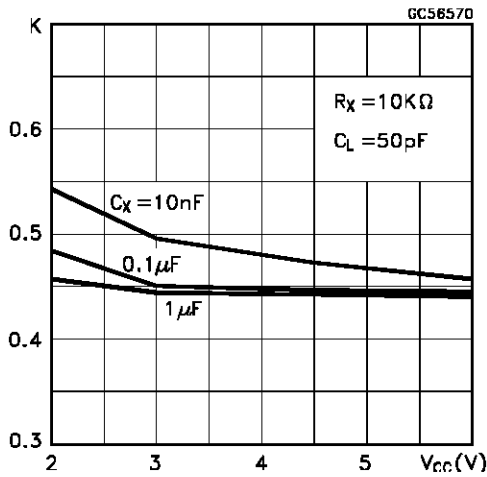

Output Pulse Width Constant Characteristics (for HC123A)

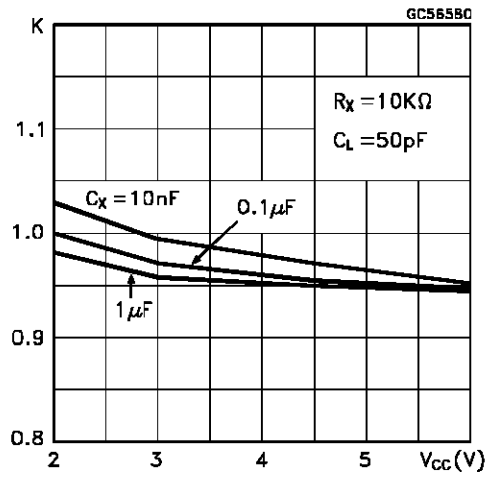

Output Pulse Width Characteristics (for HC123)

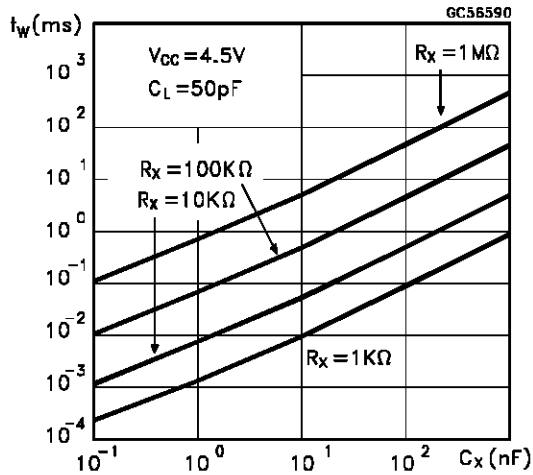

Output Pulse Width Characteristics (for HC123A)

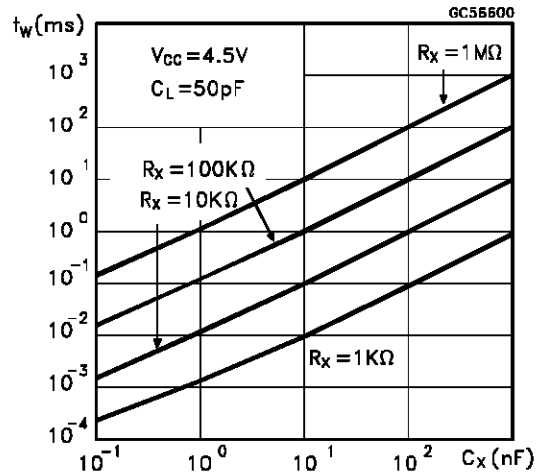

TEST CIRCUIT I_{CC} (Opr)

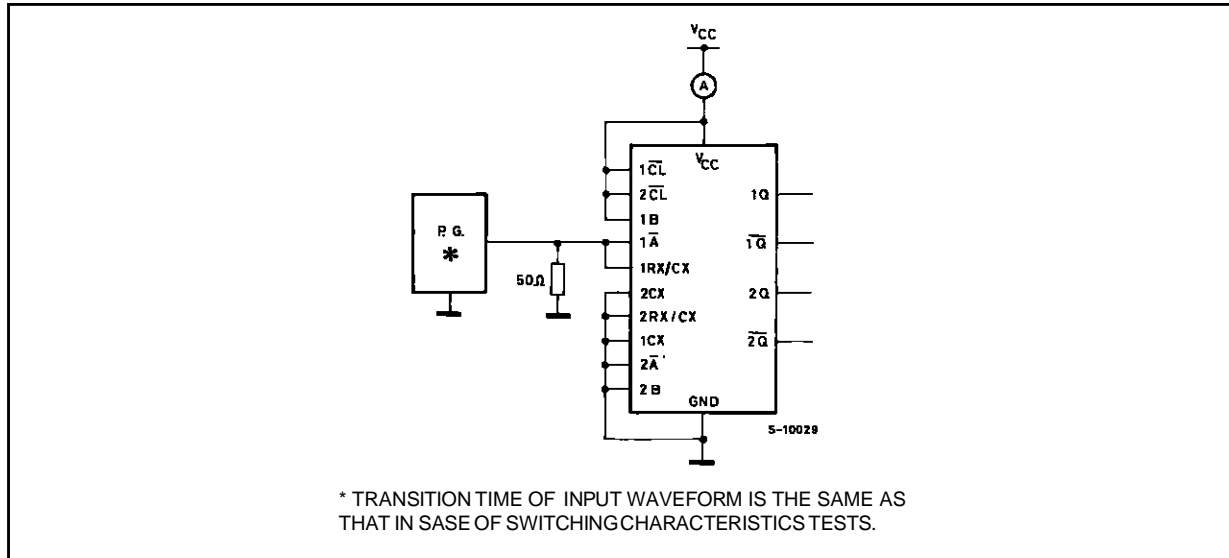

SWITCHING CHARACTERISTICS TEST WAVEFORM

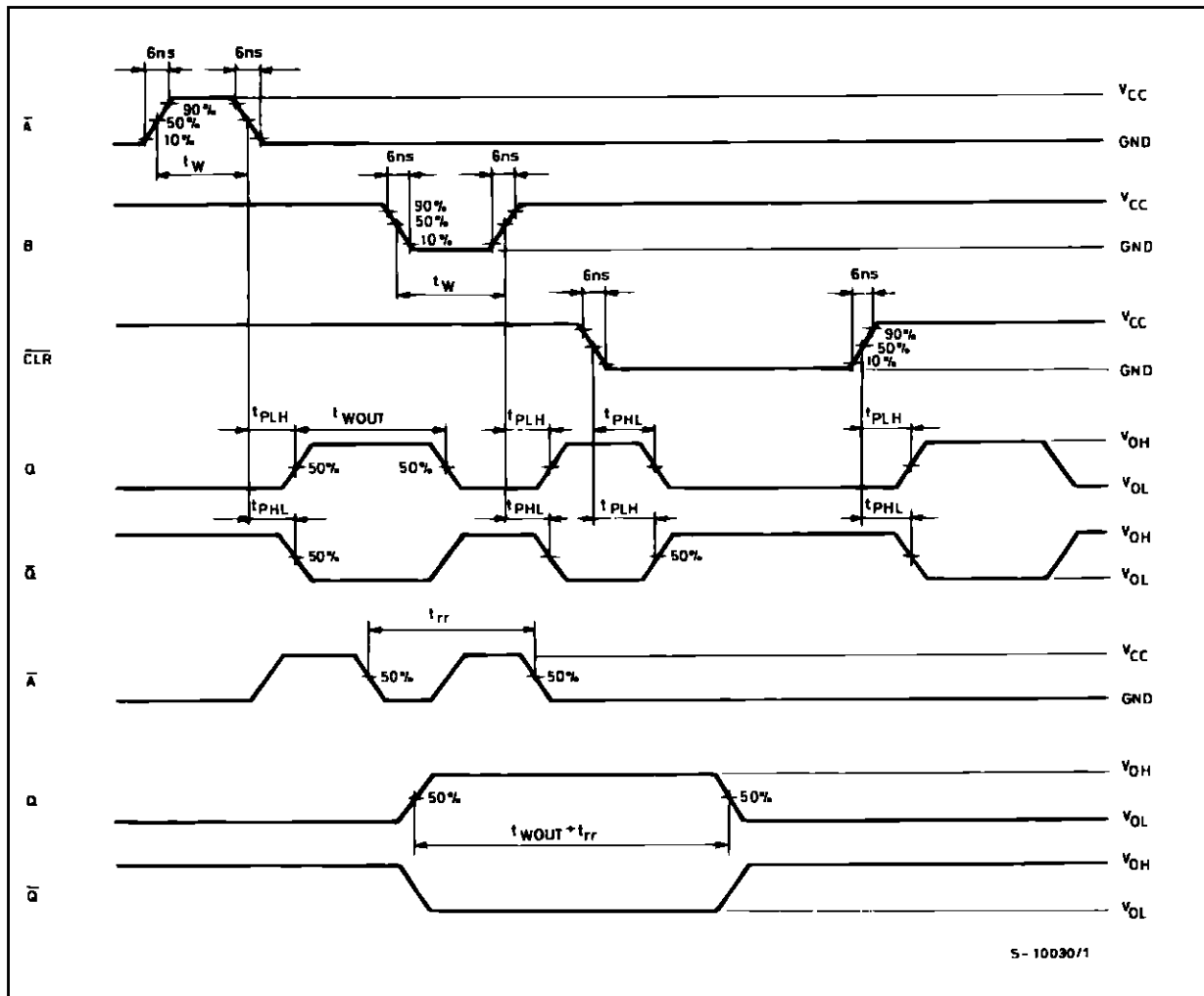

Plastic DIP16 (0.25) MECHANICAL DATA

DIM.	mm			inch		
	MIN.	TYP.	MAX.	MIN.	TYP.	MAX.
a1	0.51			0.020		
B	0.77		1.65	0.030		0.065
b		0.5			0.020	
b1		0.25			0.010	
D			20			0.787
E		8.5			0.335	
e		2.54			0.100	
e3		17.78			0.700	
F			7.1			0.280
I			5.1			0.201
L		3.3			0.130	
Z			1.27			0.050



Ceramic DIP16/1 MECHANICAL DATA

DIM.	mm			inch		
	MIN.	TYP.	MAX.	MIN.	TYP.	MAX.
A			20			0.787
B			7			0.276
D		3.3			0.130	
E	0.38			0.015		
e3		17.78			0.700	
F	2.29		2.79	0.090		0.110
G	0.4		0.55	0.016		0.022
H	1.17		1.52	0.046		0.060
L	0.22		0.31	0.009		0.012
M	0.51		1.27	0.020		0.050
N			10.3			0.406
P	7.8		8.05	0.307		0.317
Q			5.08			0.200



SO16 (Narrow) MECHANICAL DATA

DIM.	mm			inch		
	MIN.	TYP.	MAX.	MIN.	TYP.	MAX.
A			1.75			0.068
a1	0.1		0.2	0.004		0.007
a2			1.65			0.064
b	0.35		0.46	0.013		0.018
b1	0.19		0.25	0.007		0.010
C		0.5			0.019	
c1	45° (typ.)					
D	9.8		10	0.385		0.393
E	5.8		6.2	0.228		0.244
e		1.27			0.050	
e3		8.89			0.350	
F	3.8		4.0	0.149		0.157
G	4.6		5.3	0.181		0.208
L	0.5		1.27	0.019		0.050
M			0.62			0.024
S	8° (max.)					



P013H

PLCC20 MECHANICAL DATA

DIM.	mm			inch		
	MIN.	TYP.	MAX.	MIN.	TYP.	MAX.
A	9.78		10.03	0.385		0.395
B	8.89		9.04	0.350		0.356
D	4.2		4.57	0.165		0.180
d1		2.54			0.100	
d2		0.56			0.022	
E	7.37		8.38	0.290		0.330
e		1.27			0.050	
e3		5.08			0.200	
F		0.38			0.015	
G			0.101			0.004
M		1.27			0.050	
M1		1.14			0.045	



Information furnished is believed to be accurate and reliable. However, SGS-THOMSON Microelectronics assumes no responsibility for the consequences of use of such information nor for any infringement of patents or other rights of third parties which may result from its use. No license is granted by implication or otherwise under any patent or patent rights of SGS-THOMSON Microelectronics. Specifications mentioned in this publication are subject to change without notice. This publication supersedes and replaces all information previously supplied. SGS-THOMSON Microelectronics products are not authorized for use as critical components in life support devices or systems without express written approval of SGS-THOMSON Microelectronics.

© 1994 SGS-THOMSON Microelectronics - All Rights Reserved

SGS-THOMSON Microelectronics GROUP OF COMPANIES

Australia - Brazil - France - Germany - Hong Kong - Italy - Japan - Korea - Malaysia - Malta - Morocco - The Netherlands -
Singapore - Spain - Sweden - Switzerland - Taiwan - Thailand - United Kingdom - U.S.A