

MASK - PROGRAMMABLE SPEECH CIRCUITS

SPEECH CIRCUIT

- MINIMUM NUMBER OF INEXPENSIVE EXTERNAL COMPONENTS, 5 CAPACITORS AND 10 RESISTORS
- MUTE FUNCTION FOR PARALLEL OPERATION WITH DTMF GENERATOR OR DECODING IMPULSING
- LOW VOLTAGE OPERATION, DOWN TO 3.3V
- VERY SHORT START-UP TIME
- SIDETONE DISTORTION CANCELLATION

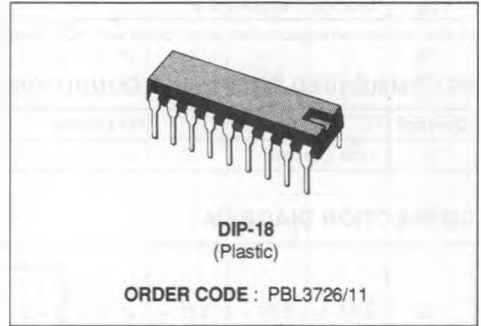

DESCRIPTON

PBL3726/11 is a standard version of the PBL3726 family of the mask-programmable, monolithic integrated speech circuits for use in electronic telephones. It is designed for use with a low impedance microphone. Sending and receiving gain is regulated with line length. Different ranges of amplifier regulation for various current feeds can be obtained with external resistor or totally cur off. Typical current feeds such as 48V 2 x 200Ω, 2 x 400Ω and 36V 2 x 250Ω can be handled.

Application-dependent parameters such as line balance, sidetone level and frequency response are set by external components. Parameters are set independently which means easy adaptation for various market needs. An extra amplifier can be used for various purposes such as active sidetone balance.

TEST CIRCUIT

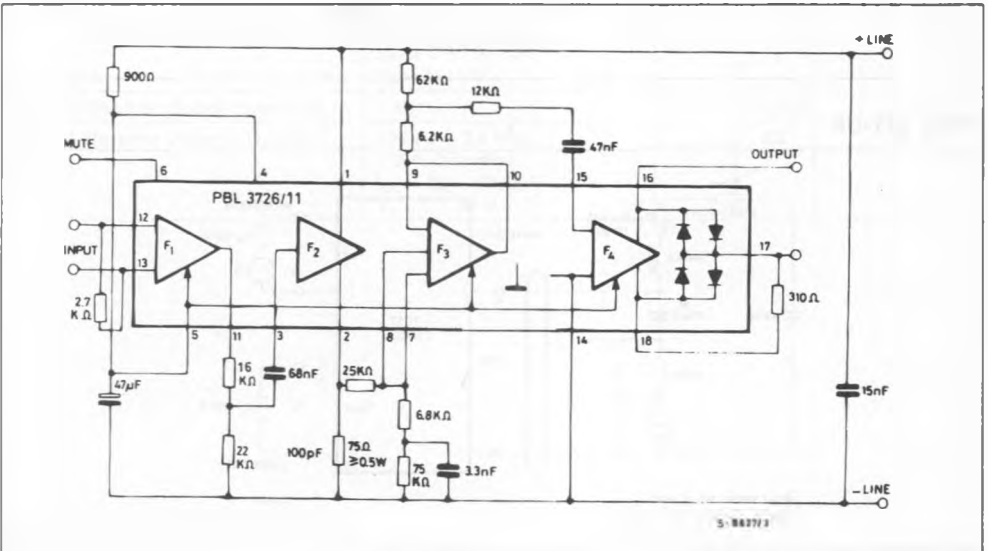

ABSOLUTE MAXIMUM RATINGS

Maximum Ratings over Operating Free-air Temperature Range (unless otherwise stated)

Symbol	Parameter	Test Conditions	Unit
V_{DC}	Line Voltage, $t_p = 2$ s	22	V
I_{DC} (*)	Continuous Operating Line Current	100	mA
T_j	Junction Temperature	150	°C
T_{amb}	Operating Ambient Temperature	- 40 to + 70	°C
T_{stg}	Storage Temperature	- 55 to + 150	°C

(*) Max. current increases linearly up to 130mA with max operating temperature lowered to + 55°C.

RECOMMENDED OPERATING CONDITIONS

Symbol	Parameter	Min.	Typ.	Max.	Unit
I_L	Line Current	15		100	mA

CONNECTION DIAGRAM

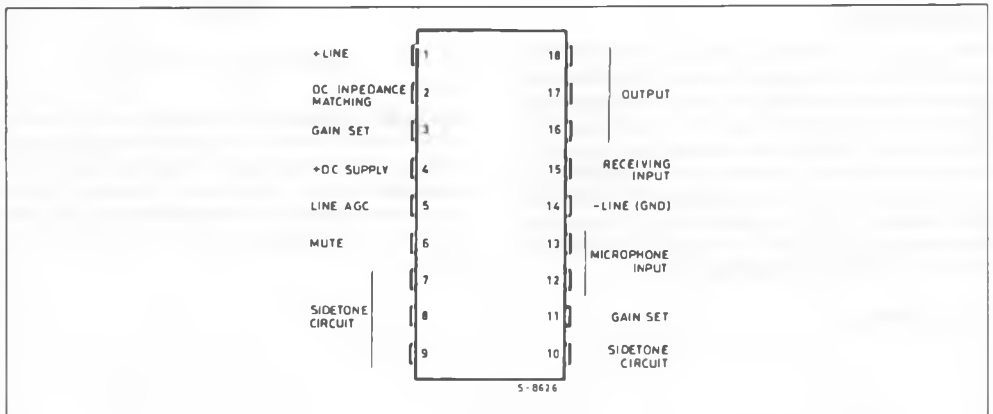

TEST SET-UP

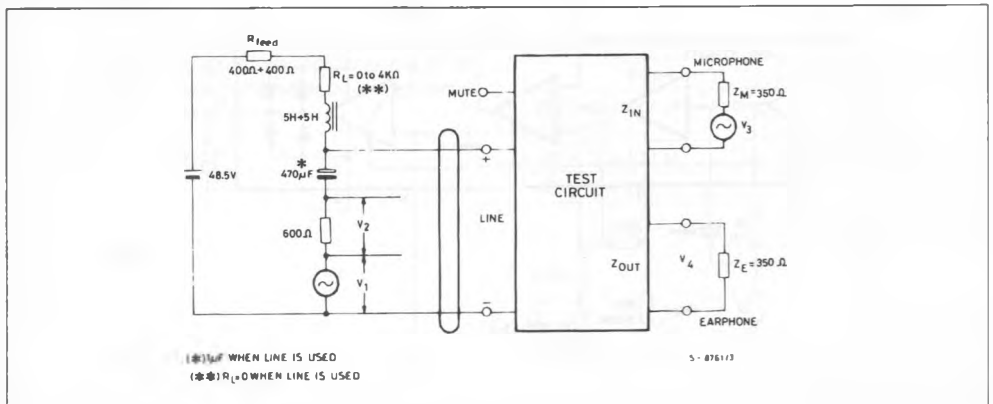

THERMAL DATA

$R_{th\ j-amb}$	Thermal Resistance Junction-ambient	Max	80	°C/W
-----------------	-------------------------------------	-----	----	------

ELECTRICAL CHARACTERISTICS (electrical characteristics over recommended operating conditions)

Symbol	Parameter	Test Conditions	Min.	Typ.	Max.	Unit
V_D	Terminal Voltage	$I_{DC} = 15\text{ mA}$ $I_{DC} = 100\text{ mA}$	3.3 11	3.7 13	4.1 15	V V
G_T	Transmitting Gain *	$20 \cdot \log_{10} \left(\frac{V_2}{V_3} \right)$ 1 kHz $R_L = 0$ $E = E + 10\%$ $R_L = 400\ \Omega$ $R_L = 900\ \Omega - 2.2\text{ kHz}$	41 43.5 46	43 45.5 48	45 47.5 50	dB dB dB
REG_T	Transmitting Range of Regulation	1 kHz $R_L = 0\ \Omega$ $E = E + 10\%$ to $R_L = 900\ \Omega$	3	5	7	dB
Lin_T	Transmitting Frequency Response	200 Hz to 3.4 kHz	- 1		1	dB
G_R	Receiving Gain *	$20 \cdot \log_{10} \left(\frac{V_4}{V_1} \right)$ 1 kHz $R_L = 0\ \Omega$ $E = E + 10\%$ $R_L = 400\ \Omega$ $R_L = 900\ \Omega - 2.2\text{ kHz}$	- 18.5 - 16 - 13.5	- 16.5 - 14 - 11.5	- 14.5 - 12 - 9.5	dB dB dB
REG_R	Receiving Range of Regulation	1 kHz $R_L = 0\ \Omega$ $E = E + 10\%$ to $R_L = 900\ \Omega$	3	5	7	dB
Lin_R	Receiving Frequency Response	200 Hz to 3.4 kHz	- 1		1	dB
Z_{IN}	Transmitter Input Impedance	1 kHz		1050		Ω
V_T	Transmitter Dynamic Output	200 Hz - 3.4 kHz $\leq 2\%$ Distortion $I_{DC} = 20 - 100\text{ mA}$		1.5		V_p
V_T	Transmitter Max Output	200 Hz - 3.4 kHz $I_{DC} = 0 - 100\text{ mA}$ $V_3 = 0 - 1\text{ V}$		3		V_p
Z_{OUT}	Receiver Output Impedance	1 kHz		3 + 310		Ω
	Receiver Dynamic Output **	200 Hz - 3.4 kHz $\leq 2\%$ Distortion $I_{DC} = 20 - 100\text{ mA}$ $V_1 = 0 - 50\text{ V}$		0.5		V_p

ELECTRICAL CHARACTERISTICS (continued)

Symbol	Parameter	Test Conditions	Min.	Typ.	Max.	Unit
V_R	Receiver Max Output	Measured with Line Rectifier 200 Hz – 3.4 kHz $I_{DC} = 0 - 100$ mA $V_1 = 0 - 50$ V		0.9		V_p
N_T	Transmitter Output Noise	P_{501} -weighted, REL 1 V $R_L = 0$		- 75		dB _{PSO1}
N_R	Receiver Output Noise	A-weighted, REL 1 V, with Cable 0-5 km Ø 0.5 mm ; 0-3 km Ø 0.4 mm		- 85		dB _A
I_M	Mute Input Current		0.1			mA
I_{DC}	Extra Available Current when Muted at the Same DC-voltage	$I_{DC} = 15 - 100$ mA		10		mA

* Adjustable to both higher and lower values with external components.

** The Dynamic output can be doubled. See application notes at R14.

Figure 1 : Typical Application.

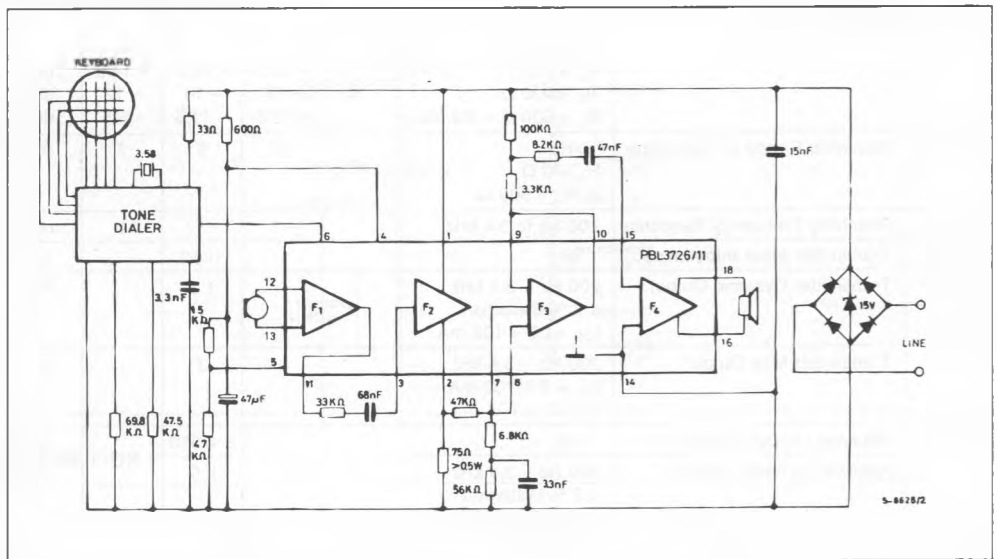

Some typical values for R1 and R2 for some different supplies from telephone stations are shown in the next table.

Type	R1	R2
No Regulation, all Feeding Systems	∞	0
48 V, 2 x 200 Ω	16 KΩ	47 KΩ
48 V, 2 x 400 Ω	9.1 K	47 KΩ