

DATA SHEET

PCF8566

Universal LCD driver for low
multiplex rates

Product specification
Supersedes data of 1996 Oct 29
File under Integrated Circuits, IC12

1996 Dec 03

Universal LCD driver for low multiplex rates

PCF8566

FEATURES

- Single-chip LCD controller/driver
- Selectable backplane drive configuration: static or 2, 3 or 4 backplane multiplexing
- Selectable display bias configuration: static, $\frac{1}{2}$ or $\frac{1}{3}$
- Internal LCD bias generation with voltage-follower buffers
- 24 segment drives: up to twelve 8-segment numeric characters; up to six 15-segment alphanumeric characters; or any graphics of up to 96 elements
- 24×4 -bit RAM for display data storage
- Auto-incremented display data loading across device subaddress boundaries
- Display memory bank switching in static and duplex drive modes
- Versatile blinking modes
- LCD and logic supplies may be separated
- 2.5 to 6 V power supply range
- Low power consumption
- Power saving mode for extremely low power consumption in battery-operated and telephone applications
- I²C-bus interface
- TTL/CMOS compatible
- Compatible with any 4-bit, 8-bit or 16-bit microprocessors/microcontrollers
- May be cascaded for large LCD applications (up to 1536 segments possible)
- Cascadable with the 40 segment LCD driver PCF8576C
- Optimized pinning for single plane wiring in both single and multiple PCF8566 applications
- Space-saving 40 lead plastic very small outline package (VSO40; SOT158-1)
- No external components required (even in multiple device applications)
- Manufactured in silicon gate CMOS process.



GENERAL DESCRIPTION

The PCF8566 is a peripheral device which interfaces to almost any Liquid Crystal Display (LCD) having low multiplex rates. It generates the drive signals for any static or multiplexed LCD containing up to four backplanes and up to 24 segments and can easily be cascaded for larger LCD applications. The PCF8566 is compatible with most microprocessors/microcontrollers and communicates via a two-line bidirectional I²C-bus. Communication overheads are minimized by a display RAM with auto-incremented addressing, by hardware subaddressing and by display memory switching (static and duplex drive modes).

ORDERING INFORMATION

TYPE NUMBER	PACKAGE		
	NAME	DESCRIPTION	VERSION
PCF8566P	DIP40	plastic dual in-line package; 40 leads (600 mil)	SOT129-1
PCF8566T	VSO40	plastic very small outline package; 40 leads	SOT158-1

Universal LCD driver for low multiplex rates

PCF8566

BLOCK DIAGRAM

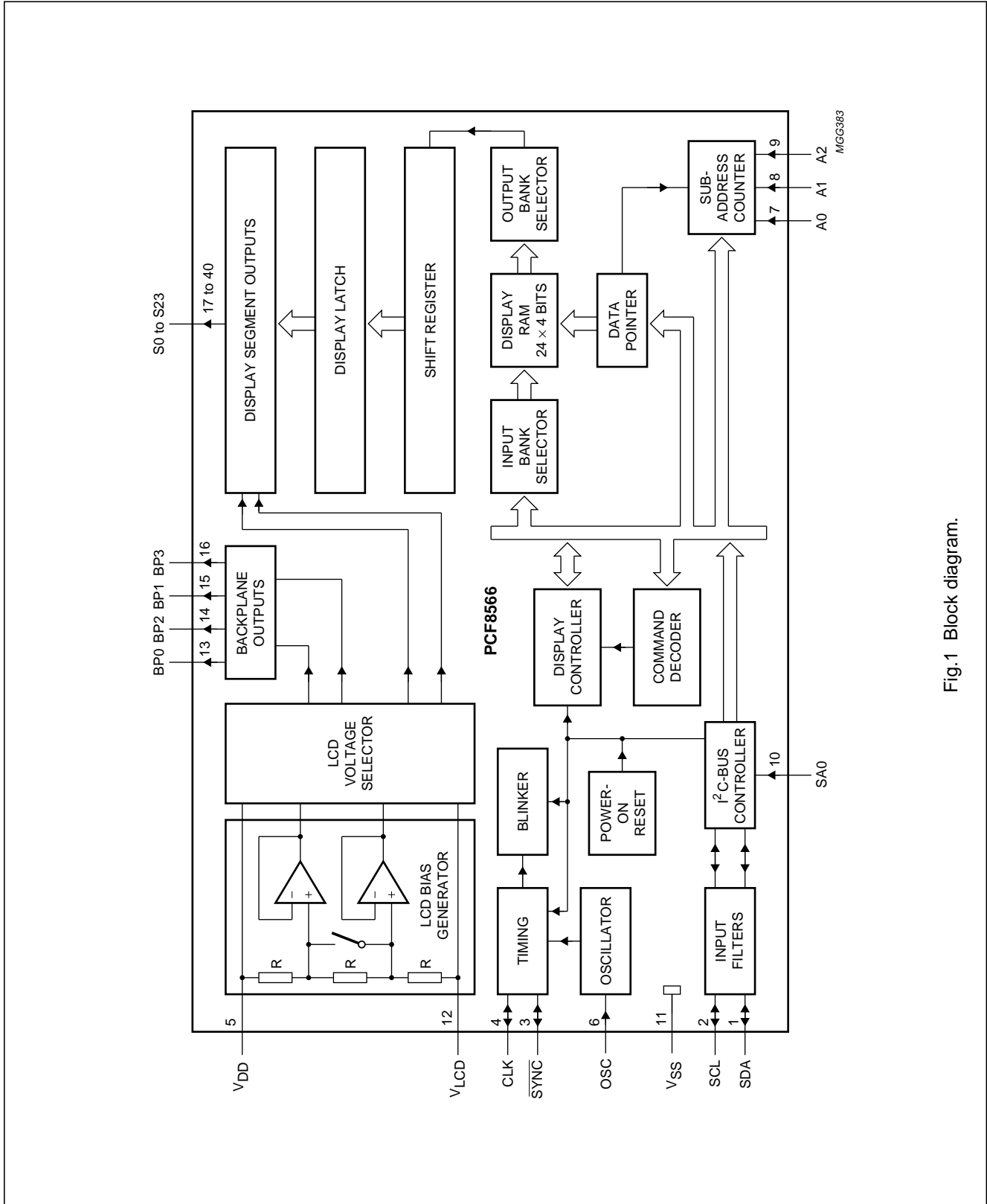

Fig.1 Block diagram.

Universal LCD driver for low multiplex rates

PCF8566

PINNING

SYMBOL	PIN	DESCRIPTION
SDA	1	I ² C-bus data input/output
SCL	2	I ² C-bus clock input/output
$\overline{\text{SYNC}}$	3	cascade synchronization input/output
CLK	4	external clock input/output
V _{DD}	5	positive supply voltage
OSC	6	oscillator input
A0	7	I ² C-bus subaddress inputs
A1	8	
A2	9	
SA0	10	I ² C-bus slave address bit 0 input
V _{SS}	11	logic ground
V _{LCD}	12	LCD supply voltage
BP0	13	LCD backplane outputs
BP2	14	
BP1	15	
BP3	16	
S0 to S23	17 to 40	LCD segment outputs

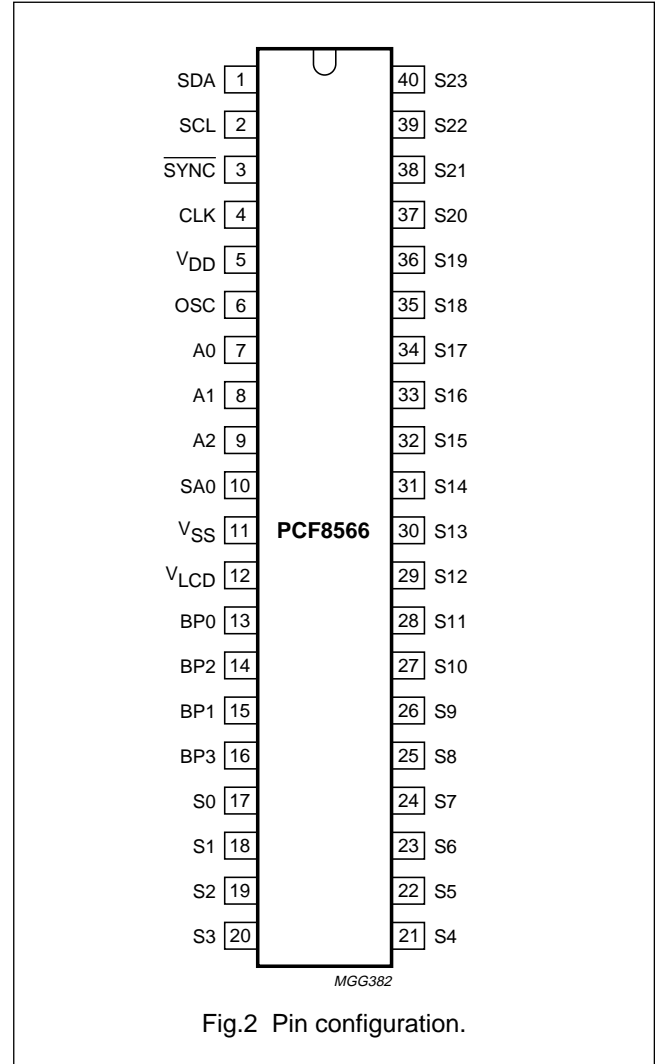

Fig.2 Pin configuration.

Universal LCD driver for low multiplex rates

PCF8566

FUNCTIONAL DESCRIPTION

The PCF8566 is a versatile peripheral device designed to interface any microprocessor to a wide variety of LCDs. It can directly drive any static or multiplexed LCD containing up to 4 backplanes and up to 24 segments. The display configurations possible with the PCF8566 depend on the number of active backplane outputs required; a selection of display configurations is given in Table 1.

All of the display configurations given in Table 1 can be implemented in the typical system shown in Fig.3. The host microprocessor/microcontroller maintains the two-line I²C-bus communication channel with the PCF8566. The internal oscillator is selected by tying OSC (pin 6) to V_{SS}. The appropriate biasing voltages for the multiplexed LCD waveforms are generated internally. The only other connections required to complete the system are to the power supplies (V_{DD}, V_{SS} and V_{LCD}) and to the LCD panel chosen for the application.

Table 1 Selection of display configurations

ACTIVE BACKPLANE OUTPUTS	NUMBER OF SEGMENTS	7-SEGMENT NUMERIC	14-SEGMENT ALPHANUMERIC	DOT MATRIX
4	96	12 digits + 12 indicator symbols	6 characters + 12 indicator symbols	96 dots (4 × 24)
3	72	9 digits + 9 indicator symbols	4 characters + 16 indicator symbols	72 dots (3 × 24)
2	48	6 digits + 6 indicator symbols	3 characters + 6 indicator symbols	48 dots (2 × 24)
1	24	3 digits + 3 indicator symbols	1 character + 10 indicator symbols	24 dots

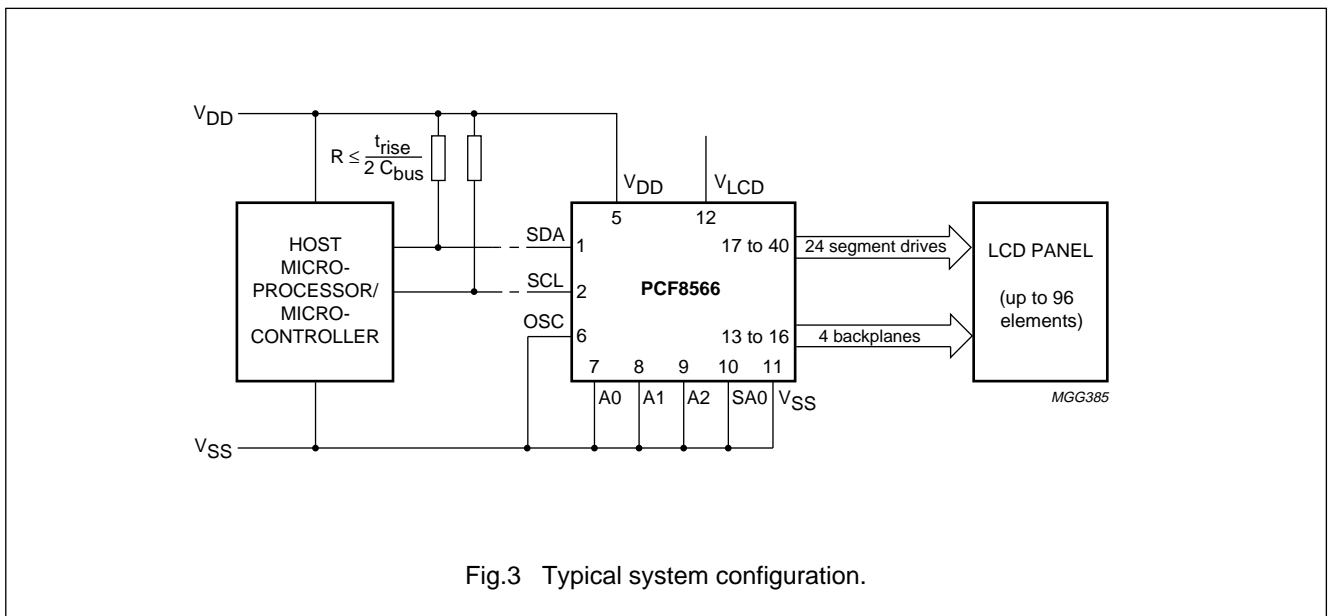

Fig.3 Typical system configuration.

Universal LCD driver for low multiplex rates

PCF8566

Power-on reset

At power-on the PCF8566 resets to a defined starting condition as follows:

1. All backplane outputs are set to V_{DD}
2. All segment outputs are set to V_{DD}
3. The drive mode '1 : 4 multiplex with $\frac{1}{3}$ bias' is selected
4. Blinking is switched off
5. Input and output bank selectors are reset (as defined in Table 5)
6. The I²C-bus interface is initialized
7. The data pointer and the subaddress counter are cleared.

Data transfers on the I²C-bus should be avoided for 1 ms following power-on to allow completion of the reset action.

LCD bias generator

The full-scale LCD voltage (V_{op}) is obtained from $V_{DD} - V_{LCD}$. The LCD voltage may be temperature compensated externally through the V_{LCD} supply to pin 12. Fractional LCD biasing voltages are obtained from an internal voltage divider of three series resistors connected between V_{DD} and V_{LCD} . The centre resistor can be switched out of circuit to provide a $\frac{1}{2}$ bias voltage level for the 1 : 2 multiplex configuration.

LCD voltage selector

The LCD voltage selector coordinates the multiplexing of the LCD according to the selected LCD drive configuration. The operation of the voltage selector is controlled by MODE SET commands from the command decoder. The biasing configurations that apply to the preferred modes of operation, together with the biasing characteristics as functions of $V_{op} = V_{DD} - V_{LCD}$ and the resulting discrimination ratios (D), are given in Table 2.

A practical value of V_{op} is determined by equating $V_{off(rms)}$ with a defined LCD threshold voltage (V_{th}), typically when the LCD exhibits approximately 10% contrast. In the static drive mode a suitable choice is $V_{op} \geq 3 V_{th}$. Multiplex drive ratios of 1 : 3 and 1 : 4 with $\frac{1}{2}$ bias are possible but the discrimination and hence the contrast ratios are smaller ($\sqrt{3} = 1.732$ for 1 : 3 multiplex or $\sqrt{21}/3 = 1.528$ for 1 : 4 multiplex). The advantage of these modes is a reduction of the LCD full scale voltage V_{op} as follows:

1 : 3 multiplex ($\frac{1}{2}$ bias):

$$V_{op} = \sqrt{6} V_{op(mrs)} = 2.449 V_{off(rms)}$$

1 : 4 multiplex ($\frac{1}{2}$ bias):

$$V_{op} = \sqrt[4]{3}/3 V_{off(rms)} = 2.309 V_{off(rms)}$$

These compare with $V_{op} = 3 V_{off(rms)}$ when $\frac{1}{3}$ bias is used.

Table 2 Preferred LCD drive modes: summary of characteristics

LCD DRIVE MODE	LCD BIAS CONFIGURATION	$\frac{V_{off(rms)}}{V_{op}}$	$\frac{V_{on(rms)}}{V_{op}}$	$D = \frac{V_{on(rms)}}{V_{off(rms)}}$
Static (1 BP)	static (2 levels)	0	1	∞
1 : 2 MUX (2 BP)	$\frac{1}{2}$ (3 levels)	$\sqrt{2}/4 = 0.354$	$\sqrt{10}/4 = 0.791$	$\sqrt{5} = 2.236$
1 : 2 MUX (2 BP)	$\frac{1}{3}$ (4 levels)	$\frac{1}{3} = 0.333$	$\sqrt{5}/3 = 0.745$	$\sqrt{5} = 2.236$
1 : 3 MUX (3 BP)	$\frac{1}{3}$ (4 levels)	$\frac{1}{3} = 0.333$	$\sqrt{33}/9 = 0.638$	$\sqrt{33}/3 = 1.915$
1 : 4 MUX (4 BP)	$\frac{1}{3}$ (4 levels)	$\frac{1}{3} = 0.333$	$\sqrt{3}/3 = 0.577$	$\sqrt{3} = 1.732$

Universal LCD driver for low multiplex rates

PCF8566

LCD drive mode waveforms

The static LCD drive mode is used when a single backplane is provided in the LCD. Backplane and segment drive waveforms for this mode are shown in Fig.4.

When two backplanes are provided in the LCD the 1 : 2 multiplex drive mode applies. The PCF8566 allows use of 1/2 or 1/3 bias in this mode as shown in Figs 5 and 6.

The backplane and segment drive waveforms for the 1 : 3 multiplex drive mode (three LCD backplanes) and for the 1 : 4 multiplex drive mode (four LCD backplanes) are shown in Figs 7 and 8 respectively.

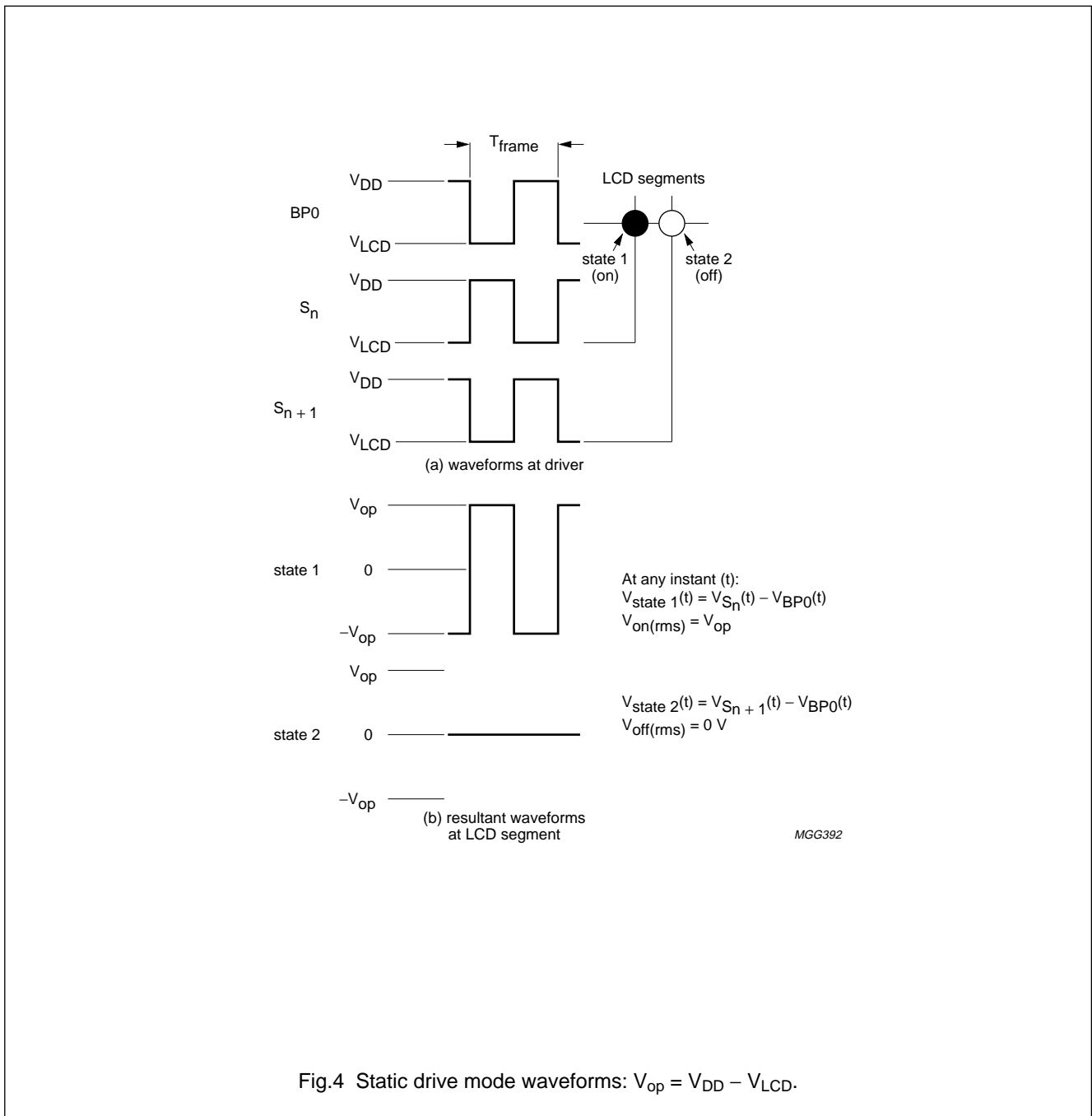

Fig.4 Static drive mode waveforms: $V_{op} = V_{DD} - V_{LCD}$.

Universal LCD driver for low multiplex rates

PCF8566

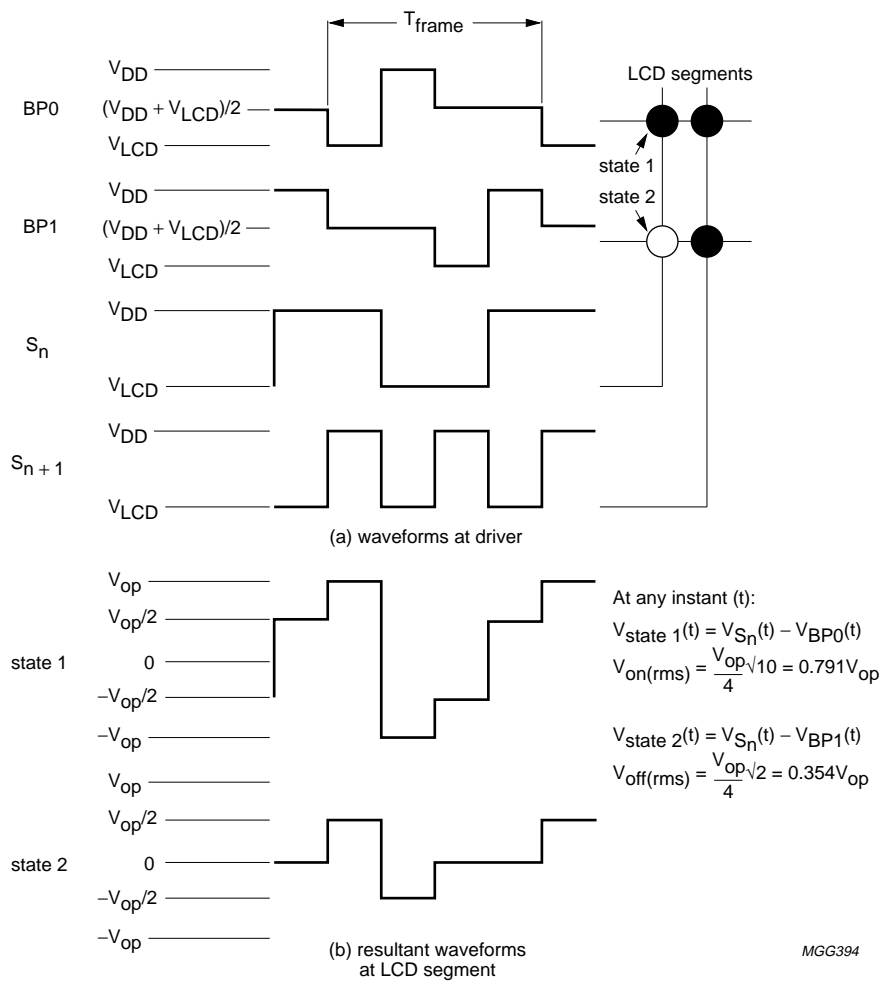

Fig.5 Waveforms for 1 : 2 multiplex drive mode with 1/2 bias: $V_{op} = V_{DD} - V_{LCD}$.

Universal LCD driver for low multiplex rates

PCF8566

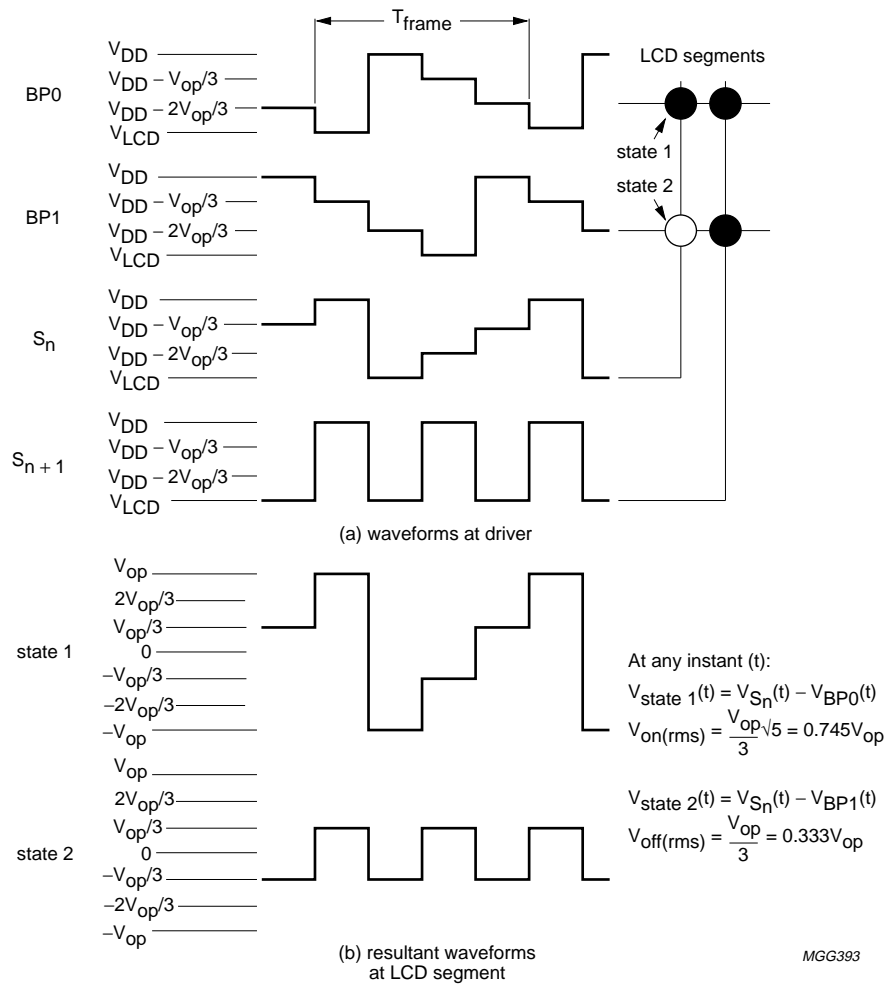

Fig.6 Waveforms for 1 : 2 multiplex drive mode with $\frac{1}{3}$ bias: $V_{op} = V_{DD} - V_{LCD}$.

Universal LCD driver for low multiplex rates

PCF8566

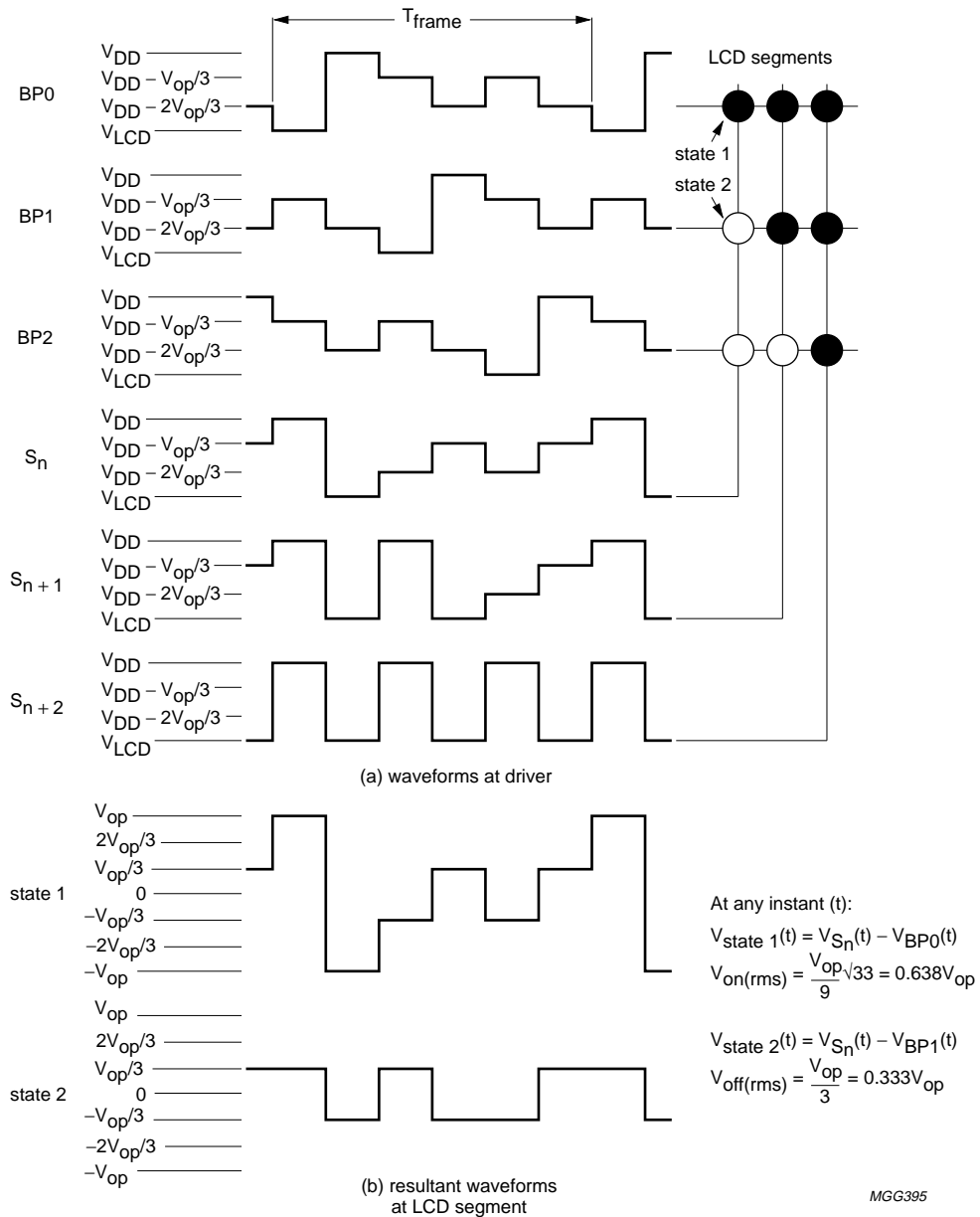

Fig.7 Waveforms for 1 : 3 multiplex drive mode: $V_{op} = V_{DD} - V_{LCD}$.

Universal LCD driver for low multiplex rates

PCF8566

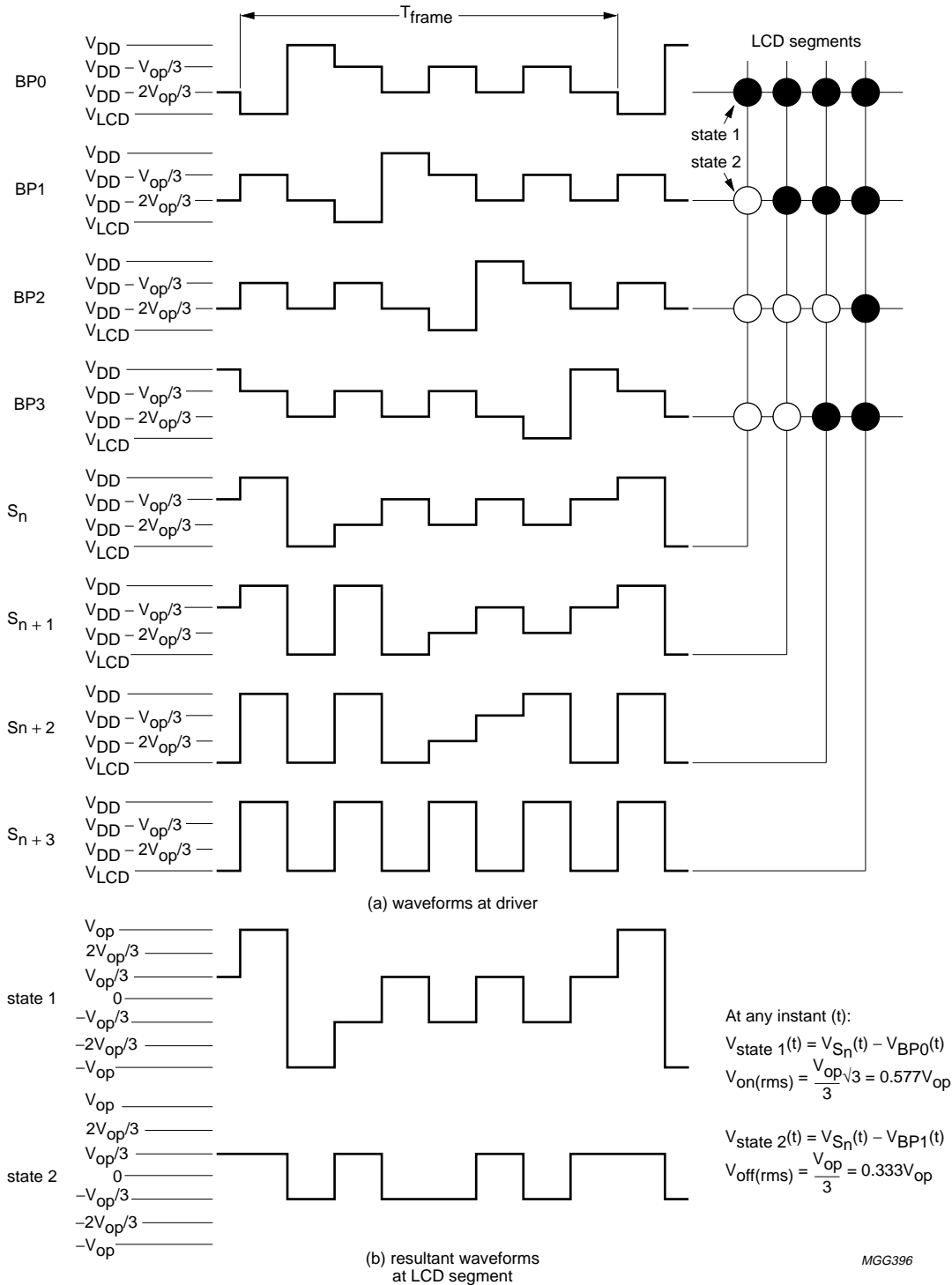

Fig.8 Waveforms for 1 : 4 multiplex drive mode: $V_{op} = V_{DD} - V_{LCD}$.

Universal LCD driver for low multiplex rates

PCF8566

Oscillator

The internal logic and the LCD drive signals of the PCF8566 or PCF8576 are timed either by the built-in oscillator or from an external clock.

The clock frequency (f_{CLK}) determines the LCD frame frequency and the maximum rate for data reception from the I²C-bus. To allow I²C-bus transmissions at their maximum data rate of 100 kHz, f_{CLK} should be chosen to be above 125 kHz.

A clock signal must always be supplied to the device; removing the clock may freeze the LCD in a DC state.

Internal clock

When the internal oscillator is used, OSC (pin 6) should be tied to V_{SS} . In this case, the output from CLK (pin 4) provides the clock signal for cascaded PCF8566s and PCF8576s in the system.

External clock

The condition for external clock is made by tying OSC (pin 6) to V_{DD} ; CLK (pin 4) then becomes the external clock input.

Timing

The timing of the PCF8566 organizes the internal data flow of the device. This includes the transfer of display data from the display RAM to the display segment outputs. In cascaded applications, the synchronization signal SYNC maintains the correct timing relationship between the PCF8566s in the system. The timing also generates the LCD frame frequency which it derives as an integer multiple of the clock frequency (Table 3). The frame frequency is set by MODE SET commands when internal clock is used, or by the frequency applied to pin 4 when external clock is used.

Table 3 LCD frame frequencies

PCF8566 MODE	f_{frame}	NOMINAL f_{frame} (Hz)
Normal mode	$f_{\text{CLK}}/2880$	64
Power saving mode	$f_{\text{CLK}}/480$	64

The ratio between the clock frequency and the LCD frame frequency depends on the mode in which the device is operating. In the power saving mode the reduction ratio is six times smaller; this allows the clock frequency to be reduced by a factor of six. The reduced clock frequency results in a significant reduction in power dissipation.

The lower clock frequency has the disadvantage of increasing the response time when large amounts of display data are transmitted on the I²C-bus. When a device is unable to 'digest' a display data byte before the next one arrives, it holds the SCL line LOW until the first display data byte is stored. This slows down the transmission rate of the I²C-bus but no data loss occurs.

Display latch

The display latch holds the display data while the corresponding multiplex signals are generated. There is a one-to-one relationship between the data in the display latch, the LCD segment outputs and one column of the display RAM.

Shift register

The shift register serves to transfer display information from the display RAM to the display latch while previous data are displayed.

Segment outputs

The LCD drive section includes 24 segment outputs S0 to S23 (pins 17 to 40) which should be connected directly to the LCD. The segment output signals are generated in accordance with the multiplexed backplane signals and with the data resident in the display latch. When less than 24 segment outputs are required the unused segment outputs should be left open-circuit.

Backplane outputs

The LCD drive section includes four backplane outputs BP0 to BP3 which should be connected directly to the LCD. The backplane output signals are generated in accordance with the selected LCD drive mode. If less than four backplane outputs are required the unused outputs can be left open. In the 1 : 3 multiplex drive mode BP3 carries the same signal as BP1, therefore these two adjacent outputs can be tied together to give enhanced drive capabilities. In the 1 : 2 multiplex drive mode BP0 and BP2, BP1 and BP3 respectively carry the same signals and may also be paired to increase the drive capabilities. In the static drive mode the same signal is carried by all four backplane outputs and they can be connected in parallel for very high drive requirements.

Display RAM

The display RAM is a static 24 × 4-bit RAM which stores LCD data. A logic 1 in the RAM bit-map indicates the 'on' state of the corresponding LCD segment; similarly, a logic 0 indicates the 'off' state.

Universal LCD driver for low multiplex rates

PCF8566

drive mode	LCD segments	LCD backplanes	display RAM filling order	transmitted display byte																																																								
static			<table border="1"> <tr> <td>n</td> <td>n+1</td> <td>n+2</td> <td>n+3</td> <td>n+4</td> <td>n+5</td> <td>n+6</td> <td>n+7</td> </tr> <tr> <td>c</td> <td>b</td> <td>a</td> <td>f</td> <td>g</td> <td>e</td> <td>d</td> <td>DP</td> </tr> <tr> <td>x</td> <td>x</td> <td>x</td> <td>x</td> <td>x</td> <td>x</td> <td>x</td> <td>x</td> </tr> <tr> <td>x</td> <td>x</td> <td>x</td> <td>x</td> <td>x</td> <td>x</td> <td>x</td> <td>x</td> </tr> <tr> <td>x</td> <td>x</td> <td>x</td> <td>x</td> <td>x</td> <td>x</td> <td>x</td> <td>x</td> </tr> </table>	n	n+1	n+2	n+3	n+4	n+5	n+6	n+7	c	b	a	f	g	e	d	DP	x	x	x	x	x	x	x	x	x	x	x	x	x	x	x	x	x	x	x	x	x	x	x	x	<table border="1"> <tr> <td colspan="4">MSB</td> <td colspan="4">LSB</td> </tr> <tr> <td>c</td> <td>b</td> <td>a</td> <td>f</td> <td>g</td> <td>e</td> <td>d</td> <td>DP</td> </tr> </table>	MSB				LSB				c	b	a	f	g	e	d	DP
n	n+1	n+2	n+3	n+4	n+5	n+6	n+7																																																					
c	b	a	f	g	e	d	DP																																																					
x	x	x	x	x	x	x	x																																																					
x	x	x	x	x	x	x	x																																																					
x	x	x	x	x	x	x	x																																																					
MSB				LSB																																																								
c	b	a	f	g	e	d	DP																																																					
1 : 2 multiplex			<table border="1"> <tr> <td>n</td> <td>n+1</td> <td>n+2</td> <td>n+3</td> </tr> <tr> <td>a</td> <td>f</td> <td>e</td> <td>d</td> </tr> <tr> <td>b</td> <td>g</td> <td>c</td> <td>DP</td> </tr> <tr> <td>x</td> <td>x</td> <td>x</td> <td>x</td> </tr> <tr> <td>x</td> <td>x</td> <td>x</td> <td>x</td> </tr> </table>	n	n+1	n+2	n+3	a	f	e	d	b	g	c	DP	x	x	x	x	x	x	x	x	<table border="1"> <tr> <td colspan="4">MSB</td> <td colspan="4">LSB</td> </tr> <tr> <td>a</td> <td>b</td> <td>f</td> <td>g</td> <td>e</td> <td>c</td> <td>d</td> <td>DP</td> </tr> </table>	MSB				LSB				a	b	f	g	e	c	d	DP																				
n	n+1	n+2	n+3																																																									
a	f	e	d																																																									
b	g	c	DP																																																									
x	x	x	x																																																									
x	x	x	x																																																									
MSB				LSB																																																								
a	b	f	g	e	c	d	DP																																																					
1 : 3 multiplex			<table border="1"> <tr> <td>n</td> <td>n+1</td> <td>n+2</td> </tr> <tr> <td>b</td> <td>a</td> <td>f</td> </tr> <tr> <td>DP</td> <td>d</td> <td>e</td> </tr> <tr> <td>c</td> <td>g</td> <td>x</td> </tr> <tr> <td>x</td> <td>x</td> <td>x</td> </tr> </table>	n	n+1	n+2	b	a	f	DP	d	e	c	g	x	x	x	x	<table border="1"> <tr> <td colspan="4">MSB</td> <td colspan="4">LSB</td> </tr> <tr> <td>b</td> <td>DP</td> <td>c</td> <td>a</td> <td>d</td> <td>g</td> <td>f</td> <td>e</td> </tr> </table>	MSB				LSB				b	DP	c	a	d	g	f	e																									
n	n+1	n+2																																																										
b	a	f																																																										
DP	d	e																																																										
c	g	x																																																										
x	x	x																																																										
MSB				LSB																																																								
b	DP	c	a	d	g	f	e																																																					
1 : 4 multiplex			<table border="1"> <tr> <td>n</td> <td>n+1</td> </tr> <tr> <td>a</td> <td>f</td> </tr> <tr> <td>c</td> <td>e</td> </tr> <tr> <td>b</td> <td>g</td> </tr> <tr> <td>DP</td> <td>d</td> </tr> </table>	n	n+1	a	f	c	e	b	g	DP	d	<table border="1"> <tr> <td colspan="4">MSB</td> <td colspan="4">LSB</td> </tr> <tr> <td>a</td> <td>c</td> <td>b</td> <td>DP</td> <td>f</td> <td>e</td> <td>g</td> <td>d</td> </tr> </table>	MSB				LSB				a	c	b	DP	f	e	g	d																														
n	n+1																																																											
a	f																																																											
c	e																																																											
b	g																																																											
DP	d																																																											
MSB				LSB																																																								
a	c	b	DP	f	e	g	d																																																					

MBE534

Fig.10 Relationships between LCD layout, drive mode, display RAM filling order and display data transmitted over the I²C-bus (X = data bit unchanged).

Universal LCD driver for low multiplex rates

PCF8566

Output bank selector

This selects one of the four bits per display RAM address for transfer to the display latch. The actual bit chosen depends on the particular LCD drive mode in operation and on the instant in the multiplex sequence. In 1 : 4 multiplex, all RAM addresses of bit 0 are the first to be selected, these are followed by the contents of bit 1, bit 2 and then bit 3. Similarly in 1 : 3 multiplex, bits 0, 1 and 2 are selected sequentially. In 1 : 2 multiplex, bits 0 then 1 are selected and, in the static mode, bit 0 is selected.

The PCF8566 includes a RAM bank switching feature in the static and 1 : 2 multiplex drive modes. In the static drive mode, the BANK SELECT command may request the contents of bit 2 to be selected for display instead of bit 0 contents. In the 1 : 2 drive mode, the contents of bits 2 and 3 may be selected instead of bits 0 and 1. This gives the provision for preparing display information in an alternative bank and to be able to switch to it once it is assembled.

Input bank selector

The input bank selector loads display data into the display RAM according to the selected LCD drive configuration. Display data can be loaded in bit 2 in static drive mode or in bits 2 and 3 in 1 : 2 drive mode by using the BANK SELECT command. The input bank selector functions independently of the output bank selector.

Blinker

The display blinking capabilities of the PCF8566 are very versatile. The whole display can be blinked at frequencies selected by the BLINK command. The blinking frequencies are integer multiples of the clock frequency; the ratios between the clock and blinking frequencies depend on the mode in which the device is operating, as shown in Table 4.

An additional feature is for an arbitrary selection of LCD segments to be blinked. This applies to the static and 1 : 2 LCD drive modes and can be implemented without any communication overheads. By means of the output bank selector, the displayed RAM banks are exchanged with alternate RAM banks at the blinking frequency. This mode can also be specified by the BLINK command.

In the 1 : 3 and 1 : 4 multiplex modes, where no alternate RAM bank is available, groups of LCD segments can be blinked by selectively changing the display RAM data at fixed time intervals.

If the entire display is to be blinked at a frequency other than the nominal blinking frequency, this can be effectively performed by resetting and setting the display enable bit E at the required rate using the MODE SET command.

Table 4 Blinking frequencies

BLINKING MODE	NORMAL OPERATING MODE RATIO	POWER-SAVING MODE RATIO	NOMINAL BLINKING FREQUENCY f_{blink} (Hz)
Off	–	–	blinking off
2 Hz	$f_{\text{CLK}}/92160$	$f_{\text{CLK}}/15360$	2
1 Hz	$f_{\text{CLK}}/184320$	$f_{\text{CLK}}/30720$	1
0.5 Hz	$f_{\text{CLK}}/368640$	$f_{\text{CLK}}/61440$	0.5

Universal LCD driver for low multiplex rates

PCF8566

I²C-BUS DESCRIPTION

The I²C-bus is for 2-way, 2-line communication between different ICs or modules. The two lines are a serial data line (SDA) and a serial clock line (SCL). Both lines must be connected to a positive supply via a pull-up resistor when connected to the output stages of a device. Data transfer may be initiated only when the bus is not busy.

Bit transfer

One data bit is transferred during each clock pulse. The data on the SDA line must remain stable during the HIGH period of the clock pulse as changes in the data line at this time will be interpreted as control signals.

Start and stop conditions

Both data and clock lines remain HIGH when the bus is not busy. A HIGH-to-LOW transition of the data line while the clock is HIGH is defined as the START condition (S). A LOW-to-HIGH transition of the data line while the clock is HIGH is defined as the STOP condition (P).

System configuration

A device generating a message is a 'transmitter', a device receiving a message is a 'receiver'. The device that controls the message is the 'master' and the devices which are controlled by the master are the 'slaves'.

Acknowledge

The number of data bytes transferred between the START and STOP conditions from transmitter to receiver is not limited. Each byte is followed by one acknowledge bit. The acknowledge bit is a HIGH level put on the bus by the transmitter whereas the master generates an extra acknowledge related clock pulse. A slave receiver which is addressed must generate an acknowledge after the reception of each byte. Also a master must generate an acknowledge after the reception of each byte that has been clocked out of the slave transmitter. The device that acknowledges has to pull down the SDA line during the acknowledge clock pulse, so that the SDA line is stable LOW during the HIGH period of the acknowledge related clock pulse, set up and hold times must be taken into account. A master receiver must signal an end of data to the transmitter by not generating an acknowledge on the last byte that has been clocked out of the slave. In this event the transmitter must leave the data line HIGH to enable the master to generate a STOP condition.

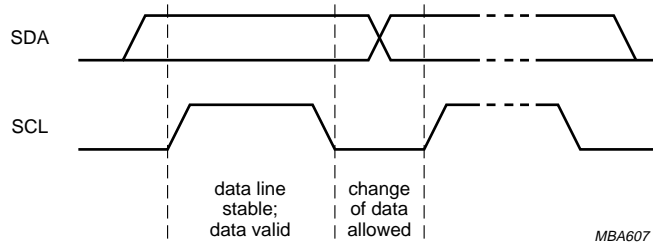

Fig.11 Bit transfer.

Universal LCD driver for low multiplex rates

PCF8566

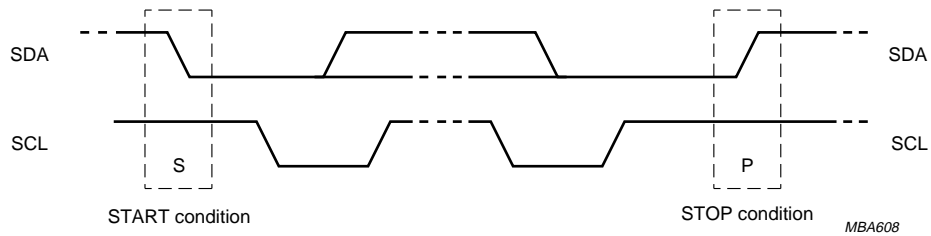

Fig.12 Definition of START and STOP conditions.

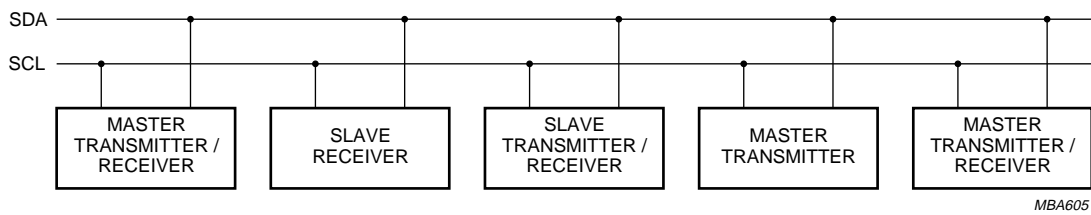

Fig.13 System configuration.

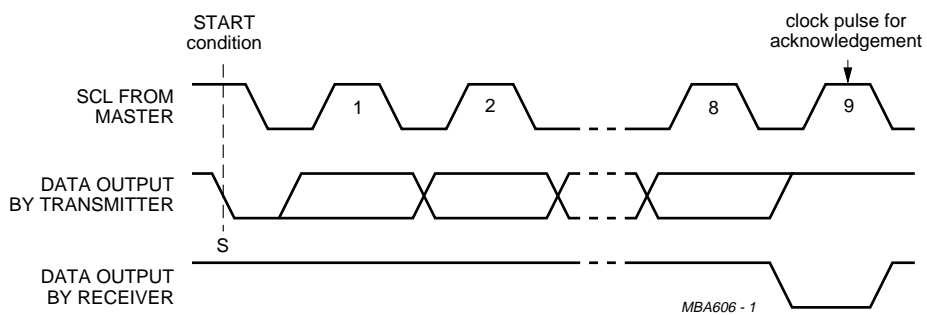

Fig.14 Acknowledgement on the I²C-bus.

Universal LCD driver for low multiplex rates

PCF8566

PCF8566 I²C-bus controller

The PCF8566 acts as an I²C-bus slave receiver. It does not initiate I²C-bus transfers or transmit data to an I²C-bus master receiver. The only data output from the PCF8566 are the acknowledge signals of the selected devices. Device selection depends on the I²C-bus slave address, on the transferred command data and on the hardware subaddress.

In single device applications, the hardware subaddress inputs A0, A1 and A2 are normally left open-circuit or tied to V_{SS} which defines the hardware subaddress 0.

In multiple device applications A0, A1 and A2 are left open-circuit or tied to V_{SS} or V_{DD} according to a binary coding scheme such that no two devices with a common I²C-bus slave address have the same hardware subaddress.

In the power-saving mode it is possible that the PCF8566 is not able to keep up with the highest transmission rates when large amounts of display data are transmitted. If this situation occurs, the PCF8566 forces the SCL line LOW until its internal operations are completed. This is known as the 'clock synchronization feature' of the I²C-bus and serves to slow down fast transmitters. Data loss does not occur.

Input filters

To enhance noise immunity in electrically adverse environments, RC low-pass filters are provided on the SDA and SCL lines.

I²C-bus protocol

Two I²C-bus slave addresses (0111110 and 0111111) are reserved for PCF8566. The least-significant bit of the slave address that a PCF8566 will respond to is defined by the level tied at its input SA0 (pin 10). Therefore, two types of PCF8566 can be distinguished on the same I²C-bus which allows:

1. Up to 16 PCF8566s on the same I²C-bus for very large LCD applications
2. The use of two types of LCD multiplex on the same I²C-bus.

The I²C-bus protocol is shown in Fig.15. The sequence is initiated with a START condition (S) from the I²C-bus master which is followed by one of the two PCF8566 slave addresses available. All PCF8566s with the corresponding SA0 level acknowledge in parallel the slave address but all PCF8566s with the alternative SA0 level ignore the whole I²C-bus transfer. After acknowledgement, one or more command bytes (m) follow which define the status of the addressed PCF8566s. The last command byte is tagged with a cleared most-significant bit, the continuation bit C. The command bytes are also acknowledged by all addressed PCF8566s on the bus.

After the last command byte, a series of display data bytes (n) may follow. These display data bytes are stored in the display RAM at the address specified by the data pointer and the subaddress counter. Both data pointer and subaddress counter are automatically updated and the data are directed to the intended PCF8566 device.

The acknowledgement after each byte is made only by the (A0, A1, A2) addressed PCF8566. After the last display byte, the I²C-bus master issues a STOP condition (P).

Command decoder

The command decoder identifies command bytes that arrive on the I²C-bus. All available commands carry a continuation bit C in their most-significant bit position (see Fig.16). When this bit is set, it indicates that the next byte of the transfer to arrive will also represent a command.

If the bit is reset, it indicates the last command byte of the transfer. Further bytes will be regarded as display data.

The five commands available to the PCF8566 are defined in Table 5.

Universal LCD driver for low multiplex rates

PCF8566

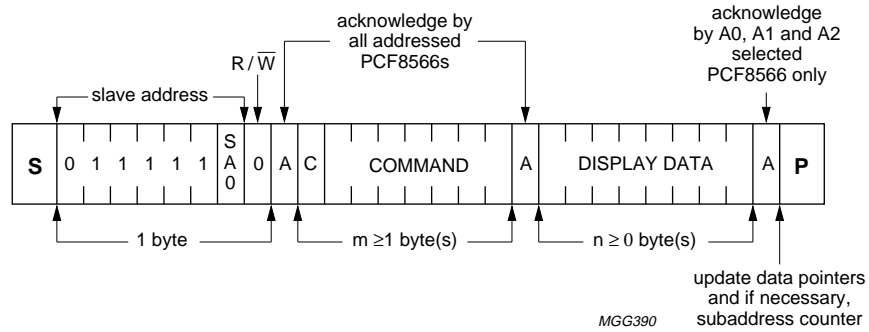

Fig.15 I²C-bus protocol.

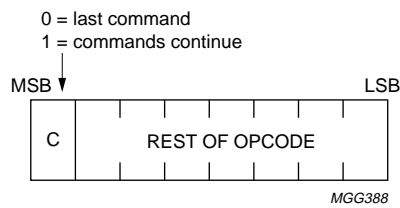

Fig.16 General format of command byte.

Universal LCD driver for low multiplex rates

PCF8566

Table 5 Definition of PCF8566 commands

COMMAND/OPCODE								OPTIONS	DESCRIPTION
Mode set									
C	1	0	LP	E	B	M1	M0	see Table 6	defines LCD drive mode
								see Table 7	defines LCD bias configuration
								see Table 8	defines display status; the possibility to disable the display allows implementation of blinking under external control
								see Table 9	defines power dissipation mode
Load data pointer									
C	0	0	P4	P3	P2	P1	P0	see Table 10	five bits of immediate data, bits P4 to P0, are transferred to the data pointer to define one of twenty-four display RAM addresses
Device select									
C	1	1	0	0	A2	A1	A0	see Table 11	three bits of immediate data, bits A0 to A2, are transferred to the subaddress counter to define one of eight hardware subaddresses
Bank select									
C	1	1	1	1	0	I	O	see Table 12	defines input bank selection (storage of arriving display data)
								see Table 13	defines output bank selection (retrieval of LCD display data)
									the BANK SELECT command has no effect in 1 : 3 and 1 : 4 multiplex drive modes
Blink									
C	1	1	1	0	A	BF1	BF0	see Table 14	defines the blinking frequency
								see Table 15	selects the blinking mode; normal operation with frequency set by bits BF1 and BF0, or blinking by alternation of display RAM banks. Alternation blinking does not apply in 1 : 3 and 1 : 4 multiplex drive modes

Table 6 LCD drive mode

LCD DRIVE MODE	BIT M1	BIT M0
Static (1 BP)	0	1
1 : 2 MUX (2 BP)	1	0
1 : 3 MUX (3 BP)	1	1
1 : 4 MUX (4 BP)	0	0

Universal LCD driver for low multiplex rates

PCF8566

Table 7 LCD bias configuration

LCD BIAS	BIT B
$\frac{1}{3}$ bias	0
$\frac{1}{2}$ bias	1

Table 8 Display status

DISPLAY STATUS	BIT E
Disabled (blank)	0
Enabled	1

Table 9 Power dissipation mode

MODE	BIT LP
Normal mode	0
Power-saving mode	1

Table 10 Load data pointer

BITS	P4	P3	P2	P1	P0
5-bit binary value of 0 to 23					

Table 11 Device select

BITS	A0	A1	A2
3-bit binary value of 0 to 7			

Table 12 Input bank selection

STATIC	1 : 2 MUX	BIT 1
RAM bit 0	RAM bits 0, 1	0
RAM bit 2	RAM bits 2, 3	1

Table 13 Output bank selection

STATIC	1 : 2 MUX	BIT 0
RAM bit 0	RAM bits 0, 1	0
RAM bit 2	RAM bits 2, 3	1

Table 14 Blinking frequency

BLINK FREQUENCY	BIT BF1	BIT BF0
Off	0	0
2 Hz	0	1
1 Hz	1	0
0.5 Hz	1	1

Table 15 Blink mode selection

BLINK MODE	BIT A
Normal blinking	0
Alternation blinking	1

Display controller

The display controller executes the commands identified by the command decoder. It contains the status registers of the PCF8566 and coordinates their effects.

The controller is also responsible for loading display data into the display RAM as required by the filling order.

Cascaded operation

In large display configurations, up to 16 PCF8566s can be distinguished on the same I²C-bus by using the 3-bit hardware subaddress (A0, A1 and A2) and the programmable I²C-bus slave address (SA0). It is also possible to cascade up to 16 PCF8566s. When cascaded, several PCF8566s are synchronized so that they can share the backplane signals from one of the devices in the cascade. Such an arrangement is cost-effective in large LCD applications since the outputs of only one device need to be through-plated to the backplane electrodes of the display. The other PCF8566s of the cascade contribute additional segment outputs but their backplane outputs are left open-circuit (Fig.17).

The $\overline{\text{SYNC}}$ line is provided to maintain the correct synchronization between all cascaded PCF8566s. This synchronization is guaranteed after the power-on reset. The only time that SYNC is likely to be needed is if synchronization is accidentally lost (e.g. by noise in adverse electrical environments; or by the definition of a multiplex mode when PCF8566s with differing SA0 levels are cascaded). $\overline{\text{SYNC}}$ is organized as an input/output pin; the output section being realized as an open-drain driver with an internal pull-up resistor. A PCF8566 asserts the SYNC line at the onset of its last active backplane signal and monitors the SYNC line at all other times.

Should synchronization in the cascade be lost, it will be restored by the first PCF8566 to assert SYNC. The timing relationships between the backplane waveforms and the SYNC signal for the various drive modes of the PCF8576 are shown in Fig.18. The waveforms are identical with the parent device PCF8576. Cascade ability between PCF8566s and PCF8576s is possible, giving cost effective LCD applications.

Universal LCD driver for low multiplex rates

PCF8566

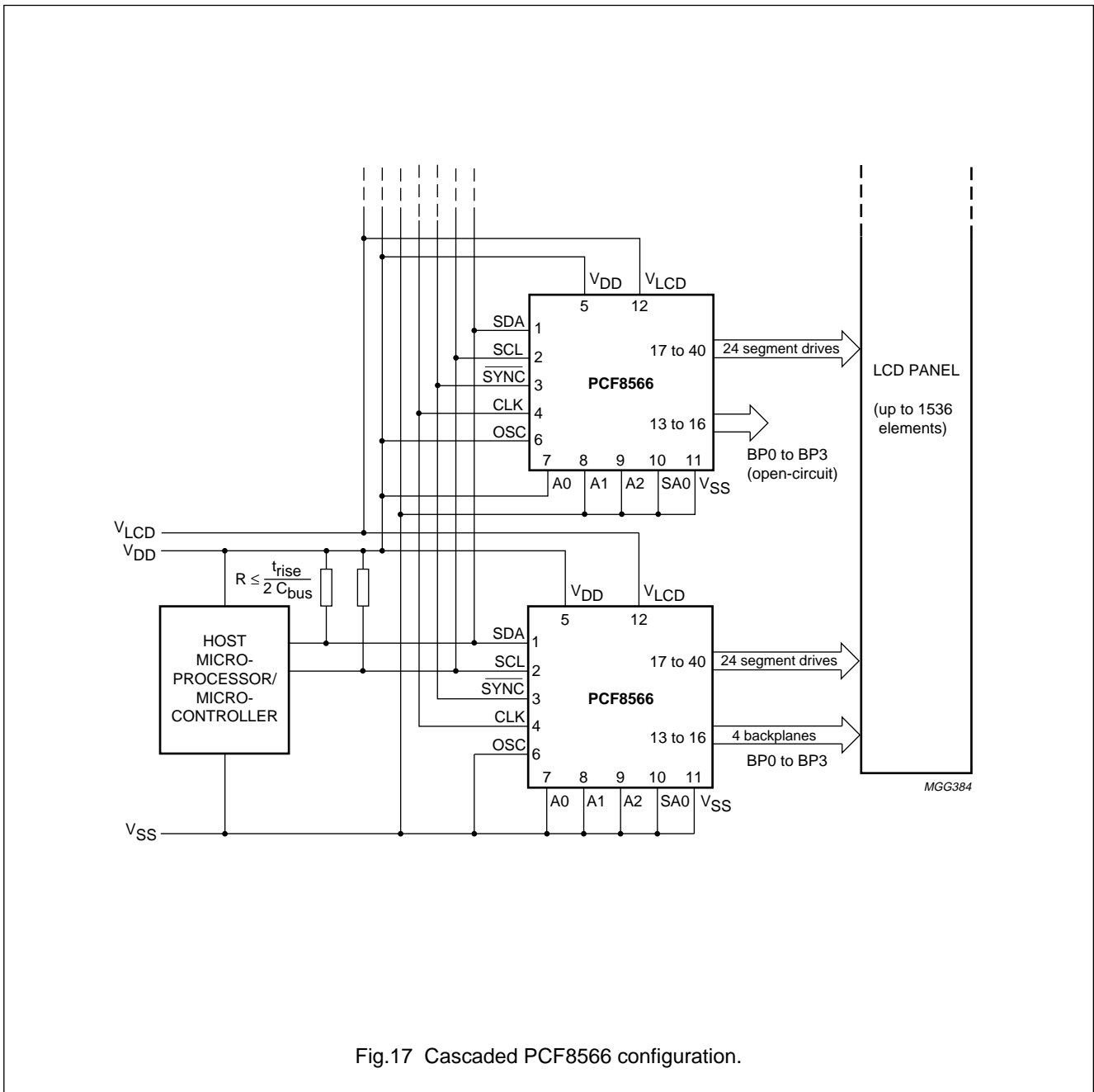

Fig.17 Cascaded PCF8566 configuration.

Universal LCD driver for low multiplex rates

PCF8566

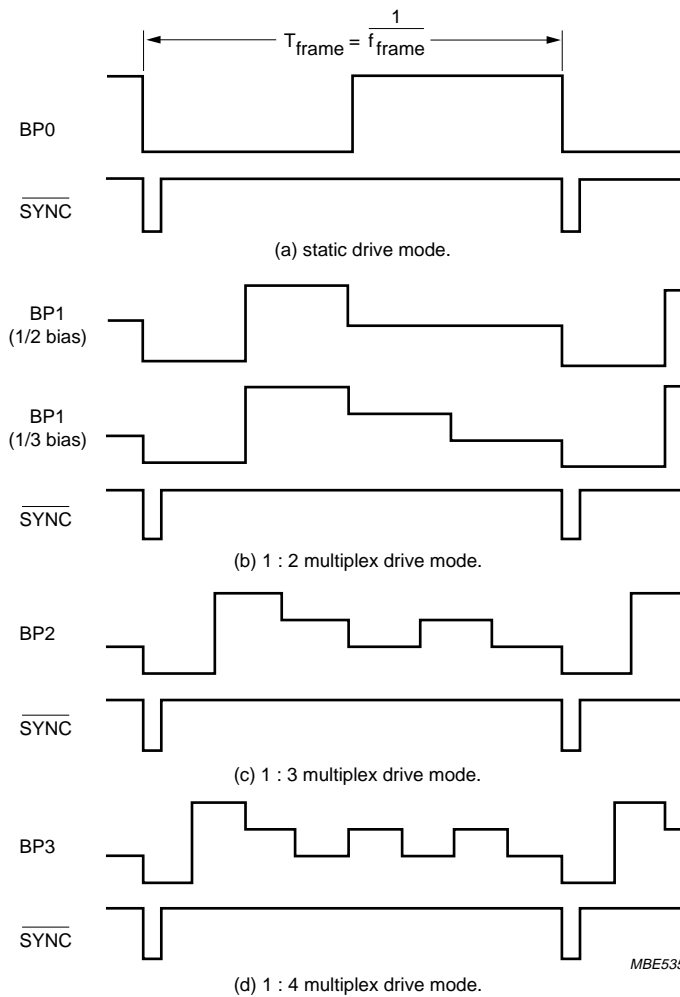

Fig.18 Synchronization of the cascade for the various PCF8566 drive modes.

For single plane wiring of PCF8566s, see Chapter "Application information".

Universal LCD driver for low multiplex rates

PCF8566

LIMITING VALUES

In accordance with the Absolute Maximum Rating System (IEC 134).

SYMBOL	PARAMETER	MIN.	MAX.	UNIT
V_{DD}	supply voltage	-0.5	+7	V
V_{LCD}	LCD supply voltage	$V_{DD} - 7$	V_{DD}	V
V_I	input voltage (SCL, SDA, A0 to A2, OSC, CLK, \overline{SYNC} and SA0)	$V_{SS} - 0.5$	$V_{DD} + 0.5$	V
V_O	output voltage (S0 to S23 and BP0 to BP3)	$V_{LCD} - 0.5$	$V_{DD} + 0.5$	V
I_I	DC input current	-	± 20	mA
I_O	DC output current	-	± 25	mA
I_{DD}, I_{SS}, I_{LCD}	V_{DD}, V_{SS} or V_{LCD} current	-	± 50	mA
P_{tot}	power dissipation per package	-	400	mW
P_O	power dissipation per output	-	100	mW
T_{stg}	storage temperature	-65	+150	°C

HANDLING

Inputs and outputs are protected against electrostatic discharges in normal handling. However, to be totally safe, it is advised to take handling precautions appropriate to handling MOS devices (see "Handling MOS devices").

Universal LCD driver for low multiplex rates

PCF8566

DC CHARACTERISTICS

$V_{SS} = 0\text{ V}$; $V_{DD} = 2.5\text{ to }6\text{ V}$; $V_{LCD} = V_{DD} - 2.5\text{ to }V_{DD} - 6\text{ V}$; $T_{amb} = -40\text{ to }+85\text{ °C}$; unless otherwise specified.

SYMBOL	PARAMETER	CONDITIONS	MIN.	TYP.	MAX.	UNIT
Supplies						
V_{DD}	operating supply voltage		2.5	–	6	V
V_{LCD}	LCD supply voltage		$V_{DD} - 6$	–	$V_{DD} - 2.5$	V
I_{DD}	operating supply current (normal mode)	$f_{CLK} = 200\text{ kHz}$; note 1	–	30	90	μA
I_{LP}	power saving mode supply current	$V_{DD} = 3.5\text{ V}$; $V_{LCD} = 0\text{ V}$; $f_{CLK} = 35\text{ kHz}$; A0, A1 and A2 tied to V_{SS} ; note 1	–	15	40	μA
Logic						
V_{IL}	LOW level input voltage		V_{SS}	–	$0.3V_{DD}$	V
V_{IH}	HIGH level input voltage		$0.7V_{DD}$	–	V_{DD}	V
V_{OL}	LOW level output voltage	$I_O = 0\text{ mA}$	–	–	0.05	V
V_{OH}	HIGH level output voltage	$I_O = 0\text{ mA}$	$V_{DD} - 0.05$	–	–	V
I_{OL1}	LOW level output current (CLK and $\overline{\text{SYNC}}$)	$V_{OL} = 1\text{ V}$; $V_{DD} = 5\text{ V}$	1	–	–	mA
I_{OH}	HIGH level output current (CLK)	$V_{OH} = 4\text{ V}$; $V_{DD} = 5\text{ V}$	–	–	–1	mA
I_{OL2}	LOW level output current (SDA and SCL)	$V_{OL} = 0.4\text{ V}$; $V_{DD} = 5\text{ V}$	3	–	–	mA
I_{LI}	leakage current (SA0, CLK, OSC, A0, A1, A2, SCL and SDA)	$V_I = V_{SS}\text{ or }V_{DD}$	–	–	± 1	μA
I_{pd}	pull-down current (A0, A1, A2 and OSC)	$V_I = 1\text{ V}$; $V_{DD} = 5\text{ V}$	15	50	150	μA
$R_{pu\overline{\text{SYNC}}}$	pull-up resistor ($\overline{\text{SYNC}}$)		15	25	60	k Ω
V_{ref}	power-on reset level	note 2	–	1.3	2	V
t_{sw}	tolerable spike width on bus		–	–	100	ns
C_i	input capacitance	note 3	–	–	7	pF
LCD outputs						
V_{BP}	DC voltage component (BP0 to BP3)	$C_{BP} = 35\text{ nF}$	–	± 20	–	mV
V_S	DC voltage component (S0 to S23)	$C_S = 5\text{ nF}$	–	± 20	–	mV
Z_{BP}	output impedance (BP0 to BP3)	$V_{LCD} = V_{DD} - 5\text{ V}$; note 4	–	1	5	k Ω
Z_S	output impedance (S0 to S23)	$V_{LCD} = V_{DD} - 5\text{ V}$; note 4	–	3	7	k Ω

Notes

1. Outputs open; inputs at V_{SS} or V_{DD} ; external clock with 50% duty factor; I²C-bus inactive.
2. Resets all logic when $V_{DD} < V_{ref}$.
3. Periodically sampled, not 100% tested.
4. Outputs measured one at a time.

Universal LCD driver for low multiplex rates

PCF8566

AC CHARACTERISTICS

$V_{SS} = 0\text{ V}$; $V_{DD} = 2.5\text{ to }6\text{ V}$; $V_{LCD} = V_{DD} - 2.5\text{ to }V_{DD} - 6\text{ V}$; $T_{amb} = -40\text{ to }+85\text{ }^{\circ}\text{C}$; unless otherwise specified; note 1.

SYMBOL	PARAMETER	CONDITIONS	MIN.	TYP.	MAX.	UNIT
f_{CLK}	oscillator frequency (normal mode)	$V_{DD} = 5\text{ V}$; note 2	125	200	315	kHz
f_{CLKLP}	oscillator frequency (power saving mode)	$V_{DD} = 3.5\text{ V}$	21	31	48	kHz
t_{CLKH}	CLK HIGH time		1	–	–	μs
t_{CLKL}	CLK LOW time		1	–	–	μs
t_{PSYNC}	$\overline{\text{SYNC}}$ propagation delay		–	–	400	ns
t_{SYNCL}	$\overline{\text{SYNC}}$ LOW time		1	–	–	μs
t_{PLCD}	driver delays with test loads	$V_{LCD} = V_{DD} - 5\text{ V}$	–	–	30	μs
I²C-bus						
t_{BUF}	bus free time		4.7	–	–	μs
$t_{HD; STA}$	START condition hold time		4	–	–	μs
t_{LOW}	SCL LOW time		4.7	–	–	μs
t_{HIGH}	SCL HIGH time		4	–	–	μs
$t_{SU; STA}$	START condition set-up time (repeated start code only)		4.7	–	–	μs
$t_{HD; DAT}$	data hold time		0	–	–	μs
$t_{SU; DAT}$	data set-up time		250	–	–	ns
t_r	rise time		–	–	1	μs
t_f	fall time		–	–	300	ns
$t_{SU; STO}$	STOP condition set-up time		4.7	–	–	μs

Notes

- All timing values referred to V_{IH} and V_{IL} levels with an input voltage swing of V_{SS} to V_{DD} .
- At $f_{CLK} < 125\text{ kHz}$, I²C-bus maximum transmission speed is derated.

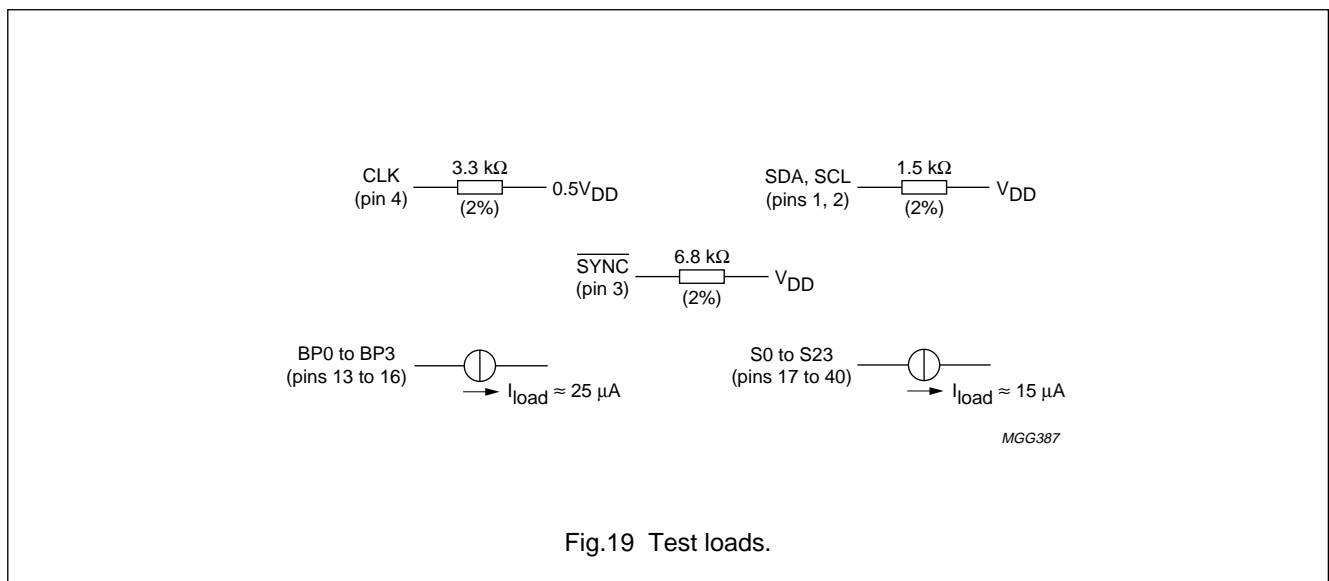

Universal LCD driver for low multiplex rates

PCF8566

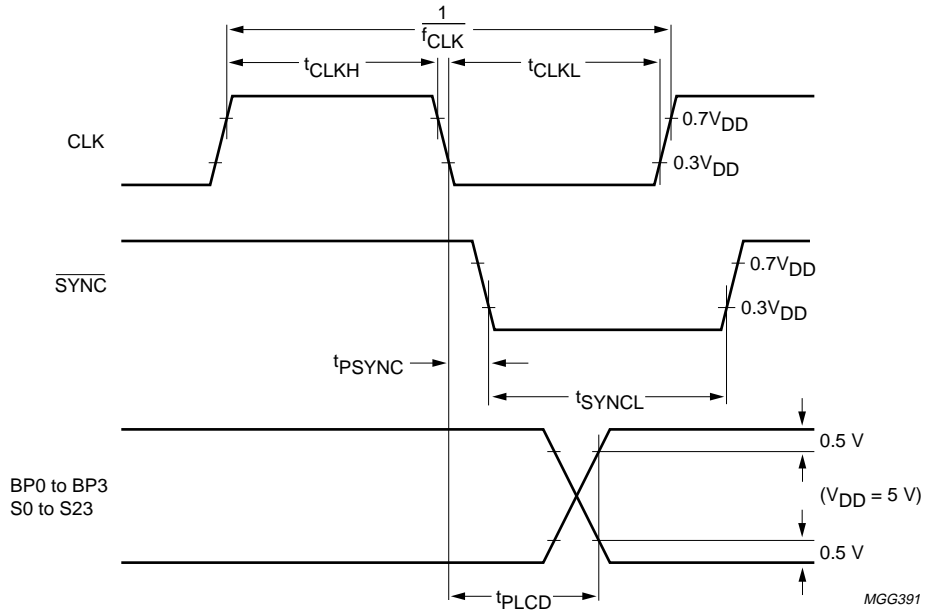

Fig.20 Driver timing waveforms.

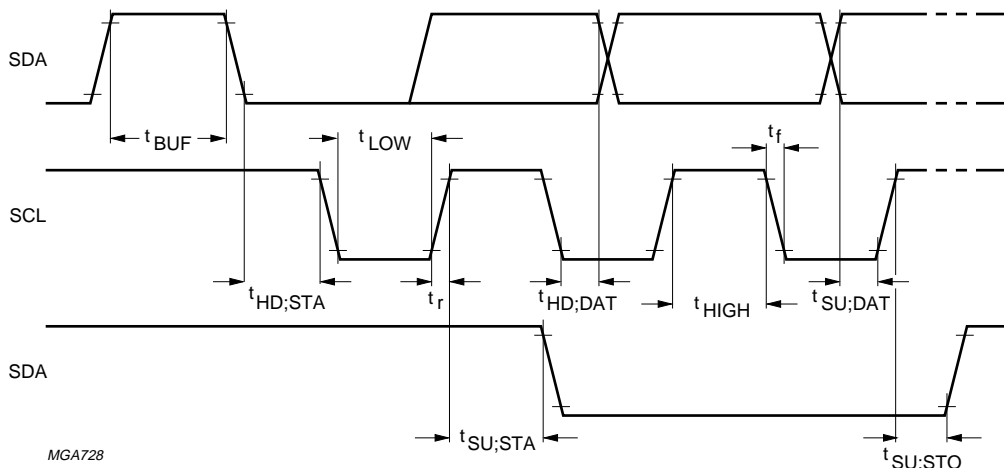
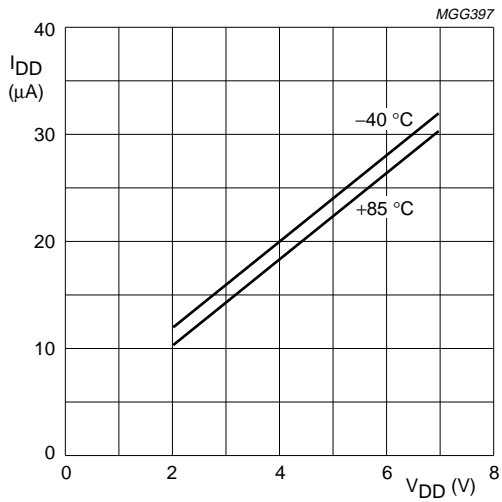

Fig.21 I²C-bus timing waveforms.

Universal LCD driver for low multiplex rates

PCF8566



a. Normal mode; V_{LCD} = 0 V;
external clock = 200 kHz.

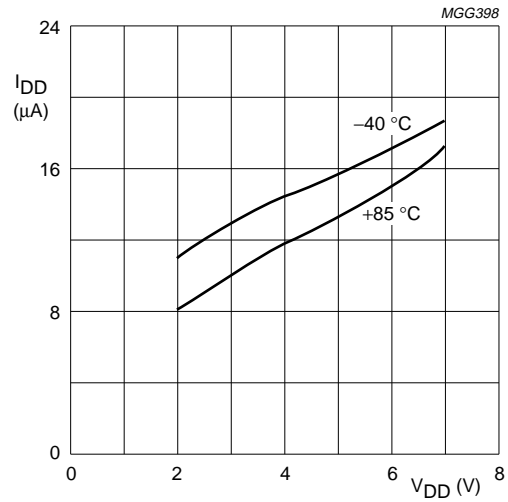

b. Low power mode; V_{LCD} = 0 V;
external clock = 35 kHz.

Fig.22 Typical supply current characteristics.

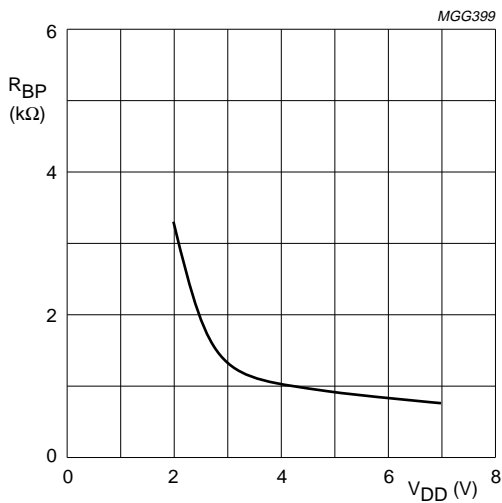

a. Backplane output impedance BP0 to BP3 (R_{BP}); V_{DD} = 5 V; T_{amb} = -40 to +85 °C.

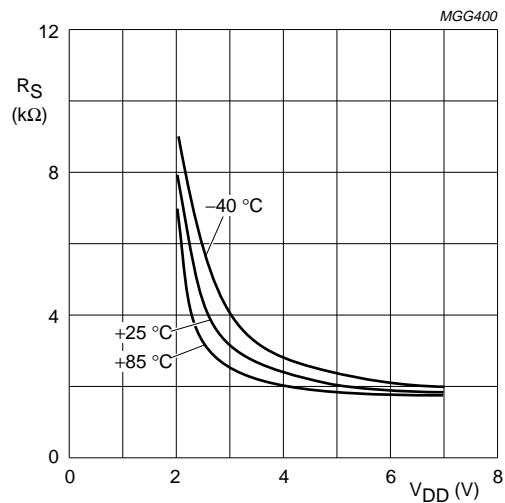

b. Segment output impedance S0 to S23 (R_S); V_{DD} = 5 V.

Fig.23 Typical characteristics of LCD outputs.

Universal LCD driver for low multiplex rates

PCF8566

APPLICATION INFORMATION

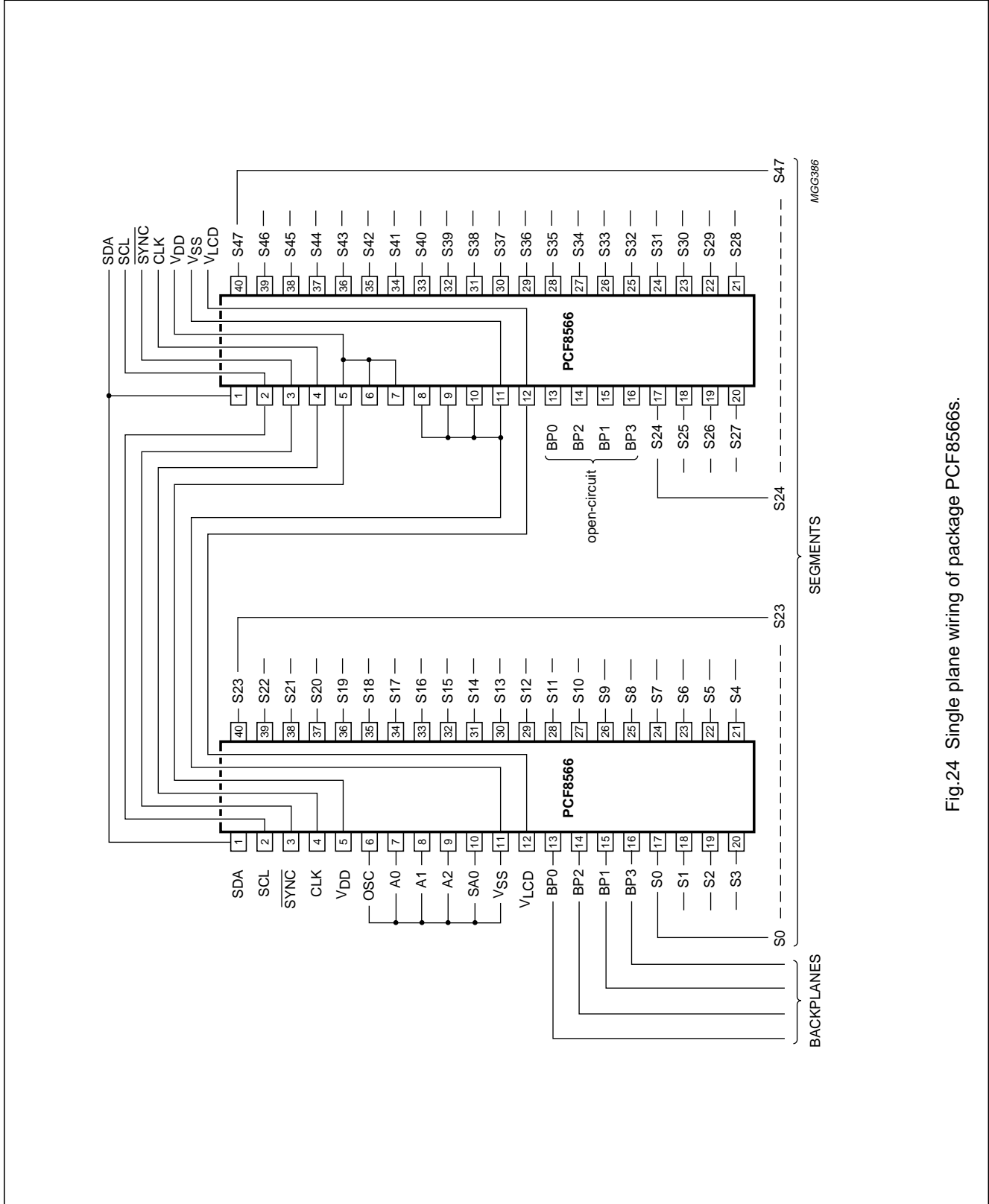
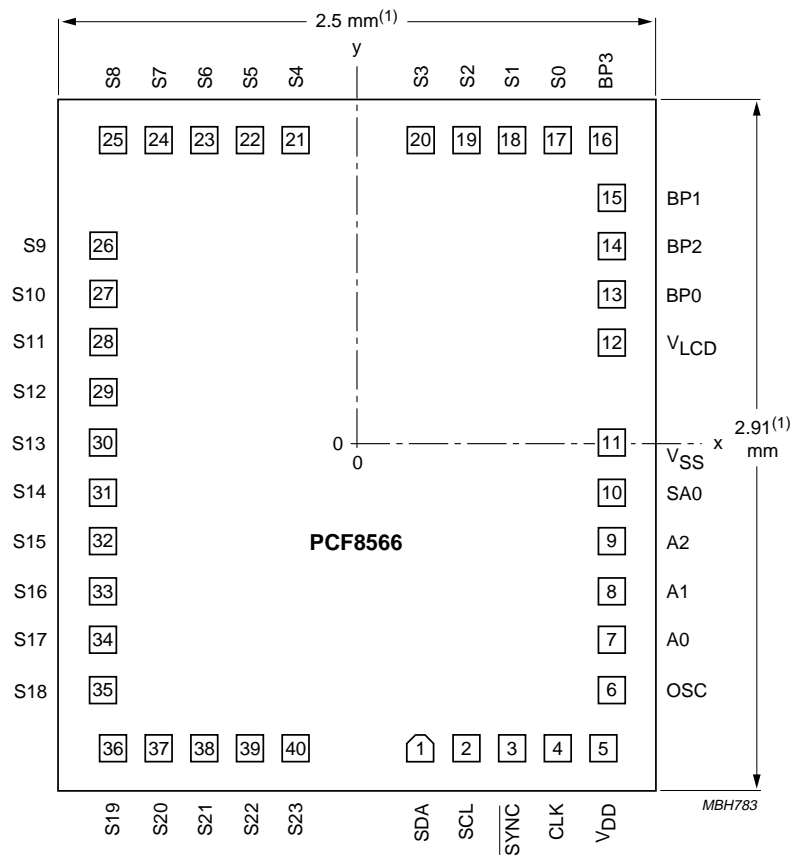

Fig.24 Single plane wiring of package PCF8566s.

Universal LCD driver for low multiplex rates

PCF8566

CHIP DIMENSIONS AND BONDING PAD LOCATIONS



(1) Typical value.

Pad size: 120 × 120 μm

Chip area: 7.27 mm.

The numbers given in the small squares refer to the pad numbers.

Fig.25 Bonding pad locations.

Universal LCD driver for low multiplex rates

PCF8566

Table 16 Bonding pad locations (dimensions in mm)

All x/y coordinates are referenced to centre of chip, (see Fig.25).

PAD NUMBER	SYMBOL	x	y	PIN
1	SDA	200	-1235	1
2	SCL	400	-1235	2
3	SYNC	605	-1235	3
4	CLK	856	-1235	4
5	V _{DD}	1062	-1235	5
6	OSC	1080	-1025	6
7	A0	1080	-825	7
8	A1	1080	-625	8
9	A2	1080	-425	9
10	SA0	1080	-225	10
11	V _{SS}	1080	-25	11
12	V _{LCD}	1080	347	12
13	BP0	1080	547	13
14	BP2	1080	747	14
15	BP1	1080	947	15
16	BP3	1074	1235	16
17	S0	674	1235	17
18	S1	674	1235	18
19	S2	474	1235	19
20	S3	274	1235	20
21	S4	-274	1235	21
22	S5	-474	1235	22
23	S6	-674	1235	23
24	S7	-874	1235	24
25	S8	-1074	1235	25
26	S9	-1080	765	26
27	S10	-1080	565	27
28	S11	-1080	365	28
29	S12	-1080	165	29
30	S13	-1080	-35	30
31	S14	-1080	-235	31
32	S15	-1080	-435	32
33	S16	-1080	-635	33
34	S17	-1080	-835	34
35	S18	-1080	-1035	35
36	S19	-1056	-1235	36
37	S20	-830	-1235	37
38	S21	-630	-1235	38
39	S22	-430	-1235	39
40	S23	-230	-1235	40

Universal LCD driver for low multiplex rates

PCF8566

PACKAGE OUTLINES

DIP40: plastic dual in-line package; 40 leads (600 mil)

SOT129-1

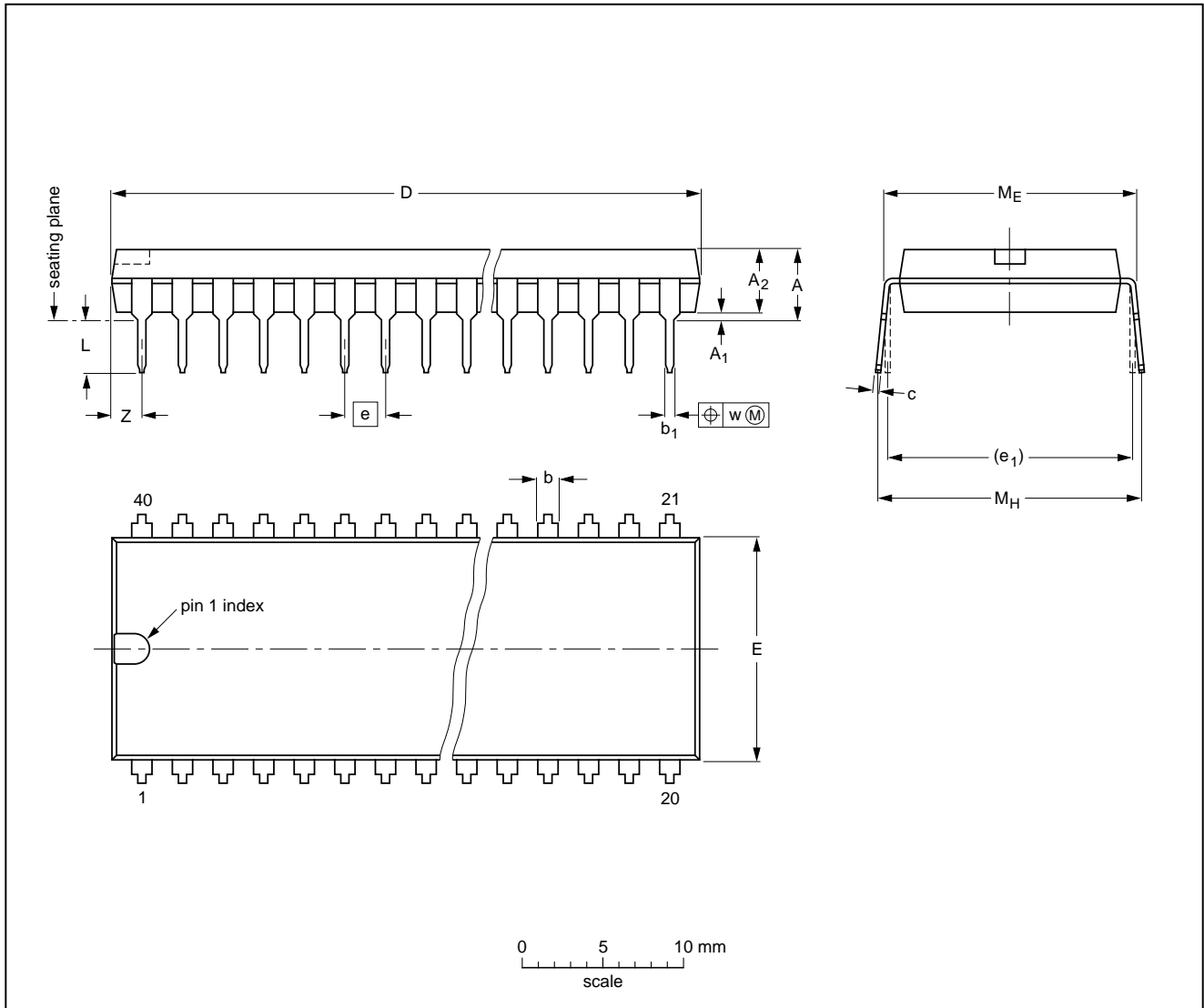

DIMENSIONS (inch dimensions are derived from the original mm dimensions)

UNIT	A max.	A ₁ min.	A ₂ max.	b	b ₁	c	D ⁽¹⁾	E ⁽¹⁾	e	e ₁	L	M _E	M _H	w	Z ⁽¹⁾ max.
mm	4.7	0.51	4.0	1.70 1.14	0.53 0.38	0.36 0.23	52.50 51.50	14.1 13.7	2.54	15.24	3.60 3.05	15.80 15.24	17.42 15.90	0.254	2.25
inches	0.19	0.020	0.16	0.067 0.045	0.021 0.015	0.014 0.009	2.067 2.028	0.56 0.54	0.10	0.60	0.14 0.12	0.62 0.60	0.69 0.63	0.01	0.089

Note

1. Plastic or metal protrusions of 0.25 mm maximum per side are not included.

OUTLINE VERSION	REFERENCES				EUROPEAN PROJECTION	ISSUE DATE
	IEC	JEDEC	EIAJ			
SOT129-1	051G08	MO-015AJ				92-11-17 95-01-14

Universal LCD driver for low multiplex rates

PCF8566

VSO40: plastic very small outline package; 40 leads

SOT158-1

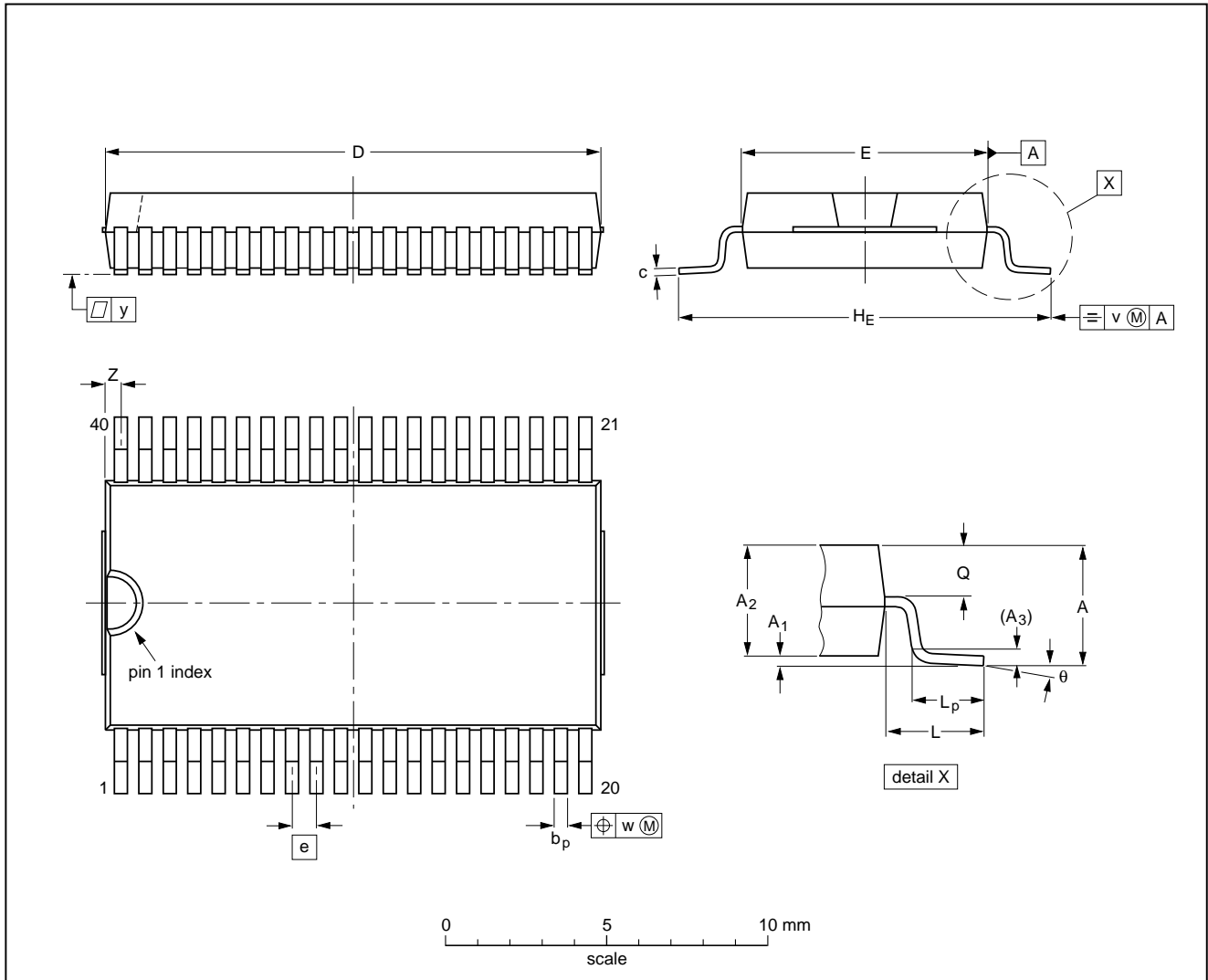

DIMENSIONS (inch dimensions are derived from the original mm dimensions)

UNIT	A max.	A ₁	A ₂	A ₃	b _p	c	D ⁽¹⁾	E ⁽²⁾	e	H _E	L	L _p	Q	v	w	y	Z ⁽¹⁾	θ
mm	2.70	0.3 0.1	2.45 2.25	0.25	0.42 0.30	0.22 0.14	15.6 15.2	7.6 7.5	0.762	12.3 11.8	2.25	1.7 1.5	1.15 1.05	0.2	0.1	0.1	0.6 0.3	7° 0°
inches	0.11	0.012 0.004	0.096 0.089	0.010	0.017 0.012	0.0087 0.0055	0.61 0.60	0.30 0.29	0.03	0.48 0.46	0.089	0.067 0.059	0.045 0.041	0.008	0.004	0.004	0.024 0.012	

Notes

1. Plastic or metal protrusions of 0.4 mm maximum per side are not included.
2. Plastic interlead protrusions of 0.25 mm maximum per side are not included.

OUTLINE VERSION	REFERENCES				EUROPEAN PROJECTION	ISSUE DATE
	IEC	JEDEC	EIAJ			
SOT158-1						92-11-17 95-01-24

Universal LCD driver for low multiplex rates

PCF8566

SOLDERING

Introduction

There is no soldering method that is ideal for all IC packages. Wave soldering is often preferred when through-hole and surface mounted components are mixed on one printed-circuit board. However, wave soldering is not always suitable for surface mounted ICs, or for printed-circuits with high population densities. In these situations reflow soldering is often used.

This text gives a very brief insight to a complex technology. A more in-depth account of soldering ICs can be found in our "*IC Package Databook*" (order code 9398 652 90011).

DIP

SOLDERING BY DIPPING OR BY WAVE

The maximum permissible temperature of the solder is 260 °C; solder at this temperature must not be in contact with the joint for more than 5 seconds. The total contact time of successive solder waves must not exceed 5 seconds.

The device may be mounted up to the seating plane, but the temperature of the plastic body must not exceed the specified maximum storage temperature ($T_{stg\ max}$). If the printed-circuit board has been pre-heated, forced cooling may be necessary immediately after soldering to keep the temperature within the permissible limit.

REPAIRING SOLDERED JOINTS

Apply a low voltage soldering iron (less than 24 V) to the lead(s) of the package, below the seating plane or not more than 2 mm above it. If the temperature of the soldering iron bit is less than 300 °C it may remain in contact for up to 10 seconds. If the bit temperature is between 300 and 400 °C, contact may be up to 5 seconds.

SO and VSO

REFLOW SOLDERING

Reflow soldering techniques are suitable for all SO and VSO packages.

Reflow soldering requires solder paste (a suspension of fine solder particles, flux and binding agent) to be applied to the printed-circuit board by screen printing, stencilling or pressure-syringe dispensing before package placement.

Several techniques exist for reflowing; for example, thermal conduction by heated belt. Dwell times vary between 50 and 300 seconds depending on heating method. Typical reflow temperatures range from 215 to 250 °C.

Preheating is necessary to dry the paste and evaporate the binding agent. Preheating duration: 45 minutes at 45 °C.

WAVE SOLDERING

Wave soldering techniques can be used for all SO and VSO packages if the following conditions are observed:

- A double-wave (a turbulent wave with high upward pressure followed by a smooth laminar wave) soldering technique should be used.
- The longitudinal axis of the package footprint must be parallel to the solder flow.
- The package footprint must incorporate solder thieves at the downstream end.

During placement and before soldering, the package must be fixed with a droplet of adhesive. The adhesive can be applied by screen printing, pin transfer or syringe dispensing. The package can be soldered after the adhesive is cured.

Maximum permissible solder temperature is 260 °C, and maximum duration of package immersion in solder is 10 seconds, if cooled to less than 150 °C within 6 seconds. Typical dwell time is 4 seconds at 250 °C.

A mildly-activated flux will eliminate the need for removal of corrosive residues in most applications.

REPAIRING SOLDERED JOINTS

Fix the component by first soldering two diagonally-opposite end leads. Use only a low voltage soldering iron (less than 24 V) applied to the flat part of the lead. Contact time must be limited to 10 seconds at up to 300 °C. When using a dedicated tool, all other leads can be soldered in one operation within 2 to 5 seconds between 270 and 320 °C.

Universal LCD driver for low multiplex rates

PCF8566

DEFINITIONS

Data sheet status	
Objective specification	This data sheet contains target or goal specifications for product development.
Preliminary specification	This data sheet contains preliminary data; supplementary data may be published later.
Product specification	This data sheet contains final product specifications.
Limiting values	
Limiting values given are in accordance with the Absolute Maximum Rating System (IEC 134). Stress above one or more of the limiting values may cause permanent damage to the device. These are stress ratings only and operation of the device at these or at any other conditions above those given in the Characteristics sections of the specification is not implied. Exposure to limiting values for extended periods may affect device reliability.	
Application information	
Where application information is given, it is advisory and does not form part of the specification.	

LIFE SUPPORT APPLICATIONS

These products are not designed for use in life support appliances, devices, or systems where malfunction of these products can reasonably be expected to result in personal injury. Philips customers using or selling these products for use in such applications do so at their own risk and agree to fully indemnify Philips for any damages resulting from such improper use or sale.

PURCHASE OF PHILIPS I²C COMPONENTS



Purchase of Philips I²C components conveys a license under the Philips' I²C patent to use the components in the I²C system provided the system conforms to the I²C specification defined by Philips. This specification can be ordered using the code 9398 393 40011.