



# High-Speed CMOS 8-Bit Buffers/Line Drivers

QS54/74FCT240T  
QS54/74FCT244T  
QS54/74FCT2240T  
QS54/74FCT2244T

## FEATURES/BENEFITS

- Pin and function compatible to the 74F240/4, 74FCT240/4 and 74ABT240/4
- Industrial temperature  $-40^{\circ}\text{C}$  to  $85^{\circ}\text{C}$
- CMOS power levels:  $<7.5\text{mW}$  static
- Available in DIP, SOIC, QSOP, ZIP, HQSOP
- Undershoot clamp diodes on all inputs
- TTL-compatible input and output levels
- Ground bounce controlled outputs
- Reduced output swing of 0-3.5V
- Military product compliant to MIL-STD-883, Class B

### FCT-T 240T, 244T

- JEDEC-FCT spec compatible
- Std. thru D speed grades with  $3.8\text{ns}$   $t_{PD}$  for D
- $I_{OL} = 64\text{mA}$  Ind.,  $48\text{mA}$  Mil.

### FCT-T 2240T, 2244T

- Built-in  $25\Omega$  series resistor outputs reduce reflection and other system noise
- Std. thru C speed grades with  $4.1\text{ns}$   $t_{PD}$  for C
- $I_{OL} = 12\text{mA}$  Ind.

## DESCRIPTION

The FCT240T and FCT244T are 8-bit buffers/line drivers with three-state outputs that are ideal for driving high-capacitance loads as in memory address and data buses. The FCT2240T and FCT2244T are  $25\Omega$  resistor output versions useful for driving transmission lines and reducing system noise. The 2240 and 2244 series parts can replace the 240/244 series to reduce noise in an existing design. All inputs have clamp diodes for undershoot noise suppression. All outputs have ground bounce suppression (see QSI Application Note AN-001), and outputs will not load an active bus when  $V_{CC}$  is removed from the device.

Figure 1. Functional Block Diagram

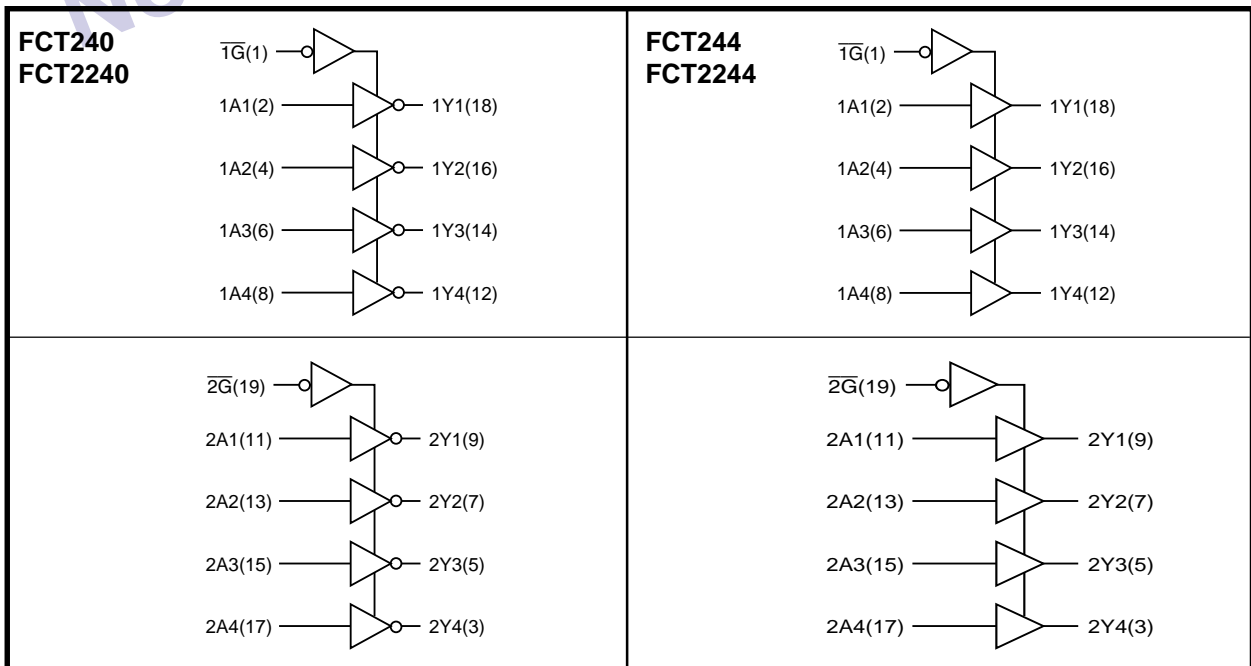

Note: Pin 19 is  $\overline{2G}$  on the FCT244.

Figure 2. Pin Configurations (All Pins Top View)

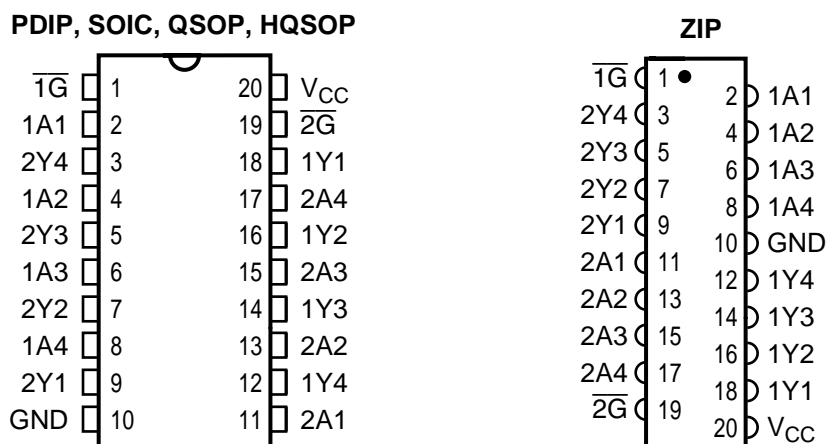

Table 1. Pin Description

Name	I/O	Description
xA4-xA0	I	Data Inputs
xY4-xY0	O	Data Outputs - Three State
$\overline{1G}/\overline{2G}$	I	Output Enables

Table 2. Function Tables

FCT240/FCT2240

$\overline{1G}/\overline{2G}$	Input A	Output Y
H	X	Z
L	L	H
L	H	L

FCT244/FCT2244

$\overline{1G}/\overline{2G}$	Input A	Output Y
H	X	Z
L	L	L
L	H	H

**Table 3. Absolute Maximum Ratings**

Supply Voltage to Ground .....	-0.5V to 7.0V
DC Output Voltage $V_{OUT}$ .....	-0.5V to 7.0V
DC Input Voltage $V_{IN}$ .....	-0.5V to 7.0V
AC Input Voltage (for a pulse width $\leq 20$ ns) .....	-3.0V
DC Input Diode Current with $V_{IN} < 0$ .....	-20mA
DC Output Diode Current with $V_{OUT} < 0$ .....	-50mA
DC Output Current Max. Sink Current/Pin .....	120mA
Maximum Power Dissipation .....	0.5 watts
$T_{STG}$ Storage Temperature .....	-65° to 150°C

**Note:** Stresses greater than those listed under ABSOLUTE MAXIMUM RATINGS may cause permanent damage to QSI devices that result in functional or reliability type failures.

**Table 4. Capacitance<sup>(1)</sup>**

$T_A = 25^\circ\text{C}$ ,  $f = 1\text{MHz}$ ,  $V_{IN} = 0\text{V}$ ,  $V_{OUT} = 0\text{V}$

Pins <sup>(2)</sup>	SOIC	QSOP	PDIP	ZIP	Unit
1, 19	4	4	5	7	pF
2-9, 11-18	8	8	9	10	pF

**Notes:**

1. Capacitance is characterized but not tested.
2. Pin reference for 20-pin package.

**Table 5. Power Supply Characteristics**

Symbol	Parameter	Test Conditions <sup>(1)</sup>	Min	Max	Unit
$I_{CC}$	Quiescent Power Supply Current	$V_{CC} = \text{Max.}$ , freq = 0 $0\text{V} \leq V_{IN} \leq 0.2\text{V}$ or $V_{CC}-0.2\text{V} \leq V_{IN} \leq V_{CC}$	—	1.5	mA
$\Delta I_{CC}$	Supply Current per Input @ TTL HIGH	$V_{CC} = \text{Max.}$ , $V_{IN} = 3.4\text{V}$ , freq = 0 <sup>(2)</sup>	—	2.0	mA
$Q_{CCD}$	Supply Current per Input per MHz	$V_{CC} = \text{Max.}$ , Outputs Open and Enabled One BitToggling @ 50% Duty Cycle Other Inputs at GND or $V_{CC}$ <sup>(3,4)</sup>	—	0.25	mA/ MHz

**Notes:**

1. For conditions shown as Min. or Max., use the appropriate values specified under DC specifications.
2. Per TTL driven input ( $V_{IN} = 3.4\text{V}$ ).
3. For flip-flops,  $Q_{CCD}$  is measured by switching one of the data input pins so that the output changes every clock cycle. This is a measurement of device power consumption only and does not include power to drive load capacitance or tester capacitance. This parameter is guaranteed by design but not tested.
4.  $I_C$  can be computed using the above parameters as explained in the Technical Overview section.

**Table 6. DC Electrical Characteristics Over Operating Range**

Industrial  $T_A = -40^{\circ}\text{C}$  to  $85^{\circ}\text{C}$ ,  $V_{CC} = 5.0\text{V} \pm 5\%$

Military  $T_A = -55^{\circ}\text{C}$  to  $125^{\circ}\text{C}$ ,  $V_{CC} = 5.0\text{V} \pm 10\%$

Symbol	Parameter	Test Conditions	Min	Typ <sup>(1)</sup>	Max	Unit
$V_{IH}$	Input HIGH Voltage	Logic HIGH for All Inputs	2.0	—	—	V
$V_{IL}$	Input LOW Voltage	Logic LOW for All Inputs	—	—	0.8	V
$\Delta V_T$	Input Hysteresis	$V_{TLH} - V_{THL}$ for All Inputs	—	0.2	—	V
$ I_{IH} $ $ I_{IL} $	Input Current Input HIGH or LOW	$V_{CC} = \text{Max.}, 0 \leq V_{IN} < V_{CC}$	—	—	5	$\mu\text{A}$
$ I_{OZ} $	Off-State Output Current (Hi-Z)	$V_{CC} = \text{Max.}, 0 \leq V_{IN} \leq V_{CC}$	—	—	5	$\mu\text{A}$
$I_{OS}$	Short Circuit Current (FCTXXX)	$V_{CC} = \text{Max.}, V_{OUT} = \text{GND}^{(2,3)}$	-60	—	—	mA
$I_{OR}$	Current Drive (FCT2XXX - 25 $\Omega$ )	$V_{CC} = \text{Min.}, V_{OUT} = 2.0\text{V}^{(3)}$	50	—	—	mA
$V_{IC}$	Input Clamp Voltage	$V_{CC} = \text{Min.}, I_{IN} = -18\text{mA}, T_A = 25^{\circ}\text{C}^{(3)}$	—	-0.7	-1.2	V
$V_{OH}$	Output HIGH Voltage	$V_{CC} = \text{Min.}$ $I_{OH} = -12\text{mA}$ (MIL) $I_{OH} = -15\text{mA}$ (IND)	2.4 2.4	— —	— —	V
$V_{OL}$	Output LOW Voltage (FCTXXX)	$V_{CC} = \text{Min.}$ $I_{OL} = 48\text{mA}$ (MIL) $I_{OL} = 64\text{mA}$ (IND)	— —	— —	0.55 0.55	V
$V_{OL}$	Output LOW Voltage (FCT2XXX - 25 $\Omega$ )	$V_{CC} = \text{Min.}$ $I_{OL} = 12\text{mA}$ (MIL) $I_{OL} = 12\text{mA}$ (IND)	— —	— —	0.50 0.50	V
$R_{OUT}$	Output Resistance (FCT2XXX - 25 $\Omega$ )	$V_{CC} = \text{Min.}$ $I_{OL} = 12\text{mA}$ (MIL) $I_{OL} = 12\text{mA}$ (IND)	— 20	25 28	— 40	$\Omega$

**Notes:**

1. Typical values indicate  $V_{CC} = 5.0\text{V}$  and  $T_A = 25^{\circ}\text{C}$ .
2. Not more than one output should be shorted and the duration is  $\leq 1$  second.
3. These parameters are guaranteed by design but not tested.

**QS54/74FCT240T, 244T, 2240T, 2244T**

**Table 7. FCT240T, FCT2240T Switching Characteristics Over Operating Range**

Industrial  $T_A = -40^{\circ}\text{C}$  to  $85^{\circ}\text{C}$ ,  $V_{CC} = 5.0\text{V} \pm 5\%$       Military  $T_A = -55^{\circ}\text{C}$  to  $125^{\circ}\text{C}$ ,  $V_{CC} = 5.0\text{V} \pm 10\%$   
 $C_{LOAD} = 50\text{pF}$ ,  $R_{LOAD} = 500\Omega$  unless otherwise noted.

Symbol	Description <sup>(1)</sup>		2240		240A 2240A		240C 2240C		240D		Unit
			Min	Max	Min	Max	Min	Max	Min	Max	
$t_{PHL}$	Propagation Delay Ai to Yi (FCT240)	IND	1.5	8	1.5	4.8	1.5	4.1	1.5	3.8	ns
$t_{PLH}$		MIL	1.5	9	1.5	5.1	1.5	4.7	—	—	
$t_{PHL}$	Propagation Delay Ai to Yi (FCT2240)	IND	1.5	8	1.5	4.8	1.5	4.1	—	—	ns
$t_{PLH}$		MIL	1.5	9	1.5	5.1	1.5	4.7	—	—	
$t_{PZH}$	Output Enable Time $\bar{G}$ to Yi (FCT240)	IND	1.5	10	1.5	6.2	1.5	5.8	1.5	5.6	ns
$t_{PZL}$		MIL	1.5	10.5	1.5	6.5	1.5	6.5	—	—	
$t_{PZH}$	Output Enable Time $\bar{G}$ to Yi (FCT2240)	IND	1.5	10	1.5	6.2	1.5	5.8	—	—	ns
$t_{PZL}$		MIL	1.5	10.5	1.5	6.5	1.5	6.5	—	—	
$t_{PHZ}$	Output Disable Time $\bar{G}$ to Yi	IND <sup>(2)</sup>	1.5	9.5	1.5	5.6	1.5	5.2	1.5	5.2	ns
$t_{PLZ}$		MIL <sup>(2)</sup>	1.5	10	1.5	5.9	1.5	5.7	—	—	

**Table 8. FCT244T, FCT2244T Switching Characteristics Over Operating Range**

Industrial  $T_A = -40^{\circ}\text{C}$  to  $85^{\circ}\text{C}$ ,  $V_{CC} = 5.0\text{V} \pm 5\%$       Military  $T_A = -55^{\circ}\text{C}$  to  $125^{\circ}\text{C}$ ,  $V_{CC} = 5.0\text{V} \pm 10\%$   
 $C_{LOAD} = 50\text{pF}$ ,  $R_{LOAD} = 500\Omega$  unless otherwise noted.

Symbol	Description <sup>(1)</sup>		244 2244		244A 2244A		244C 2244C		244D		Unit
			Min	Max	Min	Max	Min	Max	Min	Max	
$t_{PHL}$	Propagation Delay Ai to Yi (FCT244)	IND	1.5	6.5	1.5	4.8	1.5	4.1	1.5	3.8	ns
$t_{PLH}$		MIL	1.5	7.5	1.5	5.1	1.5	4.6	—	—	
$t_{PHL}$	Propagation Delay Ai to Yi (FCT2244)	IND	1.5	6.5	1.5	4.8	1.5	4.1	1.5	3.8	ns
$t_{PLH}$		MIL	1.5	7.5	1.5	5.1	1.5	4.6	—	—	
$t_{PZH}$	Output Enable Time $\bar{G}$ to Yi (FCT244)	IND	1.5	8	1.5	6.2	1.5	5.8	1.5	5.6	ns
$t_{PZL}$		MIL	1.5	8.5	1.5	6.5	1.5	6.5	—	—	
$t_{PZH}$	Output Enable Time $\bar{G}$ to Yi (FCT2244)	IND	1.5	8	1.5	6.2	1.5	5.8	1.5	5.6	ns
$t_{PZL}$		MIL	1.5	8.5	1.5	6.5	1.5	6.5	—	—	
$t_{PHZ}$	Output Disable Time $\bar{G}$ to Yi	IND <sup>(2)</sup>	1.5	7	1.5	5.6	1.5	5.2	1.5	5.2	ns
$t_{PLZ}$		MIL <sup>(2)</sup>	1.5	7.5	1.5	5.9	1.5	5.7	—	—	

**Notes:**

1. Minimums guaranteed but not tested.
2. This parameter is guaranteed by design but not tested.
3. See Test Circuit and Waveforms.