

RC4861

1/2W Audio Power Amplifier with Shutdown

Features

- Low VOS, typically 2mV
- THD 0.3% typically at 0.5W output power
- Drives 8Ω and 4Ω non-powered speakers
- User programmable gain
- Internal thermal limiting circuitry
- 8 pin SOIC package

Applications

- Multimedia PC motherboards and add-in sound cards
- Companion chip to sigma-delta sound codecs
- Low power portable systems
- Toys and games
- Cellular phones

Description

The RC4861 sound driver is an audio device that can be used on PC motherboards and add-in sound cards. It consists of H-bridge connected output drivers for headphones or speakers.

The output drivers can deliver up to 0.5 Watt of continuous average output power into 8Ω speaker from a 5V source. The drivers use class AB amplifiers and maintain a low bias current. A shut down function disables the device for power savings when not in use.

The thermal limiting circuitry becomes active if the chip temperature exceeds 150°C.

Block Diagram

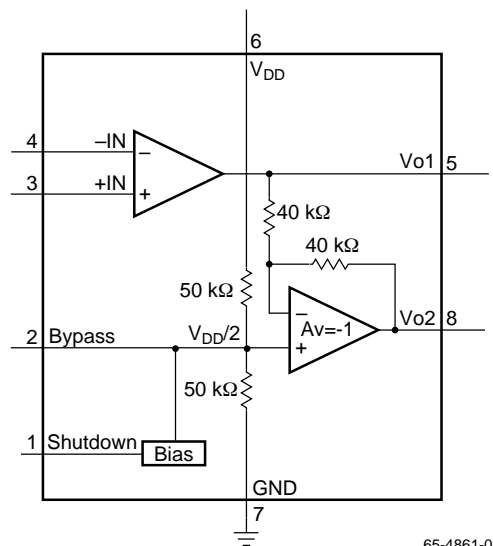

Preliminary Information

Pin Assignments

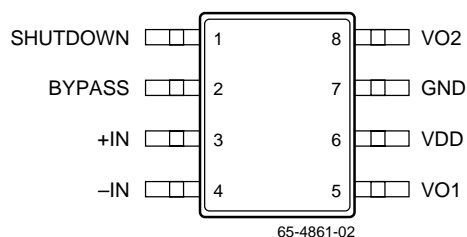

Absolute Maximum Ratings

Supply Voltage, VDD	6.0V
Junction Temperature, T _J	150°C
Storage Temperature, T _S	-65 to +150°C
Lead Soldering Temperature, 10 seconds	300°C
ESD Threshold, ESD (Human Body Model)	2000V

Note:

- Functional operation under any of these conditions is not implied. Performance is guaranteed only if Operating Conditions are not exceeded

Operating Conditions

Parameter	Conditions	Min.	Typ.	Max.	Units
Power Supply, VDD		2.7	5.0	5.5	V
Input Voltage Logic High, V _{IH}		VDD-0.8		VDD	V
Input Voltage Logic Low, V _{IL}				0.8	V
Ambient Operating Temperature, T _A		0		70	°C

Electrical Characteristics

$V_{DD} = 5V$, $f = 1kHz$, $R_L = 8\Omega$, unless otherwise specified.

Parameter	Conditions	Min.	Typ.	Max.	Units
AV	Voltage Gain, Open Loop		90		dB
I _{SS}	Shutdown current	Shutdown pin HIGH, $V_{DD} = 5V$	0.6	10	μA
I _{total}	Power Supply Current,	No load	6.5	10	mA
VOS	Output Offset Voltage	$V_{IN} = 0V$	2	20	mV
P _O	RMS Output Power	$R_L = 8\Omega$, $V_{DD} = 5V$	0.5		W
THD	Total Harmonic Distortion	$f_O = 1kHz$, $P_O = 0.5W$	0.3	1	%
PSRR	Power Supply Rejection Ratio Input Referenced	$f_O = 1kHz$, $\Delta V_{DD} = 0.2Vp-p$ 0.1 μF bypass cap	65	75	dB

Typical Application Circuit

(Demo board is available for circuit in Figure 1).

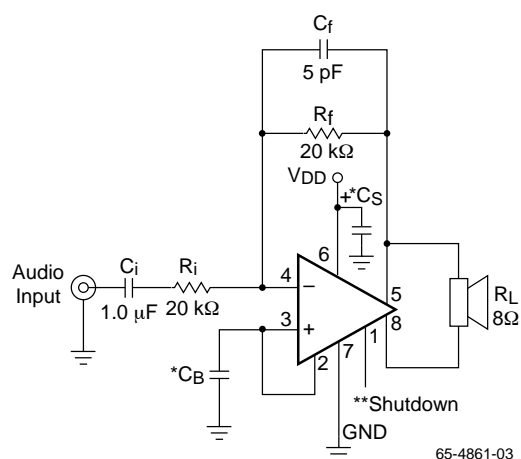

Figure 1. Audio Amplifier with $A_{VD} = 2$

* C_S and C_B size depend on specific application requirements and constraints. Typical values of C_S and C_B are 0.1 μF

**Pin 1 should be connected to V_{DD} to disable the amplifier or to GND to enable the amplifier. This pin should not be left floating.

Single Ended Application Circuit

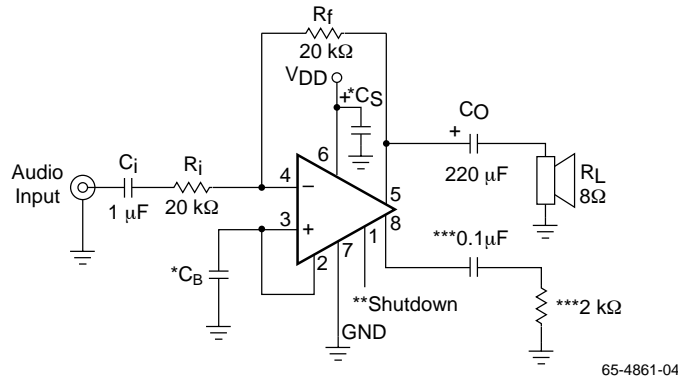

Figure 2. Single Ended Amplifier with $A_v = -1$

- * C_S and C_B size depend on specific application requirements and constraints. Typical values of C_S and C_B are $0.1 \mu F$
- **Pin 1 should be connected to V_{DD} to disable the amplifier or to GND to enable the amplifier. This pin should not be left floating.
- ***These components create a “dummy” load for pin 8 for stability purposes.

External Components Description (for Figure 1)

Components	Functional Description
R_i	Inverting input resistance which sets the closed-loop gain in conjunction with R_f . This resistor also forms a high pass filter with C_i at $f_c = 1/(2\pi R_i C_i)$.
C_i	Input coupling capacitor which blocks DC voltage at the amplifier's input terminals. Also creates a highpass filter with R_i at $f_c = 1/(2\pi R_i C_i)$.
R_f	Feedback resistance which sets closed-loop gain in conjunction with R_i . $A_v = -R_f/R_i$
C_S	Supply bypass capacitor which provides power supply filtering.
C_B	Bypass pin capacitor which provides half supply filtering.
C_f	Used when a differential gain of over 10 is desired. C_f in conjunction with R_f creates a low-pass filter which bandwidth limits the amplifier and prevents high frequency oscillation bursts. $f_c = 1/(2\pi R_f C_f)$

Preliminary Information

Typical Performance Characteristics

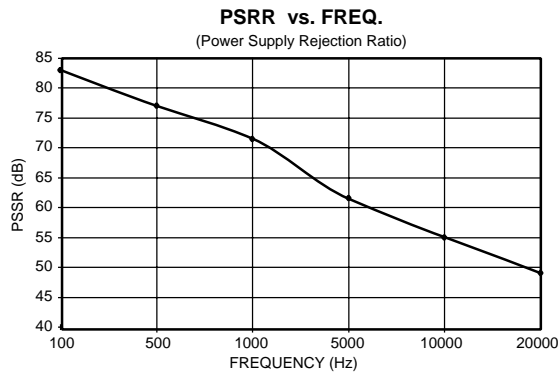
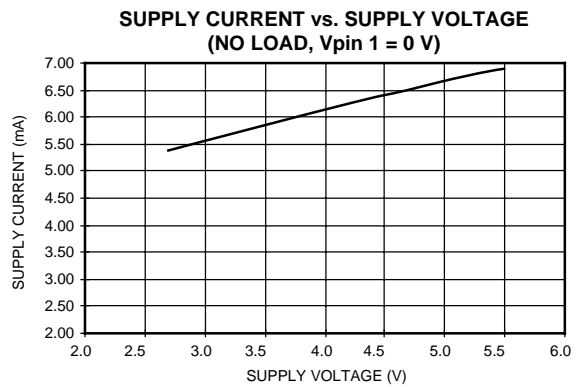
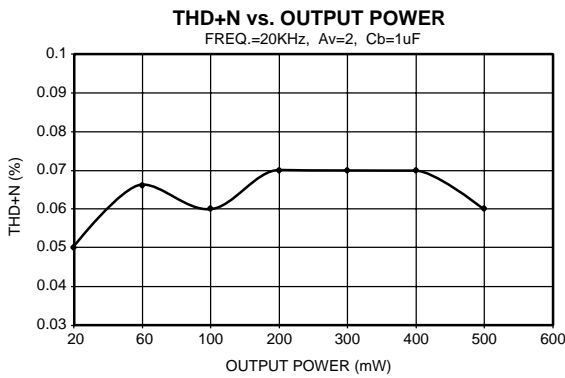
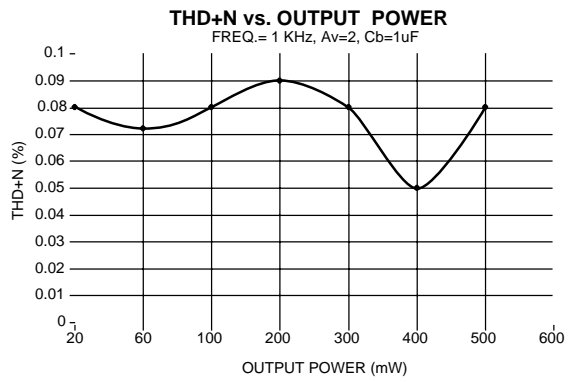
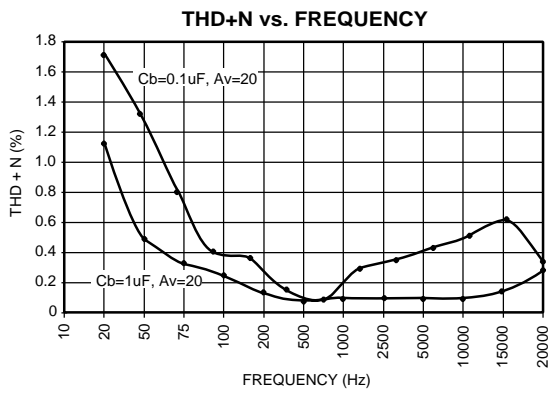
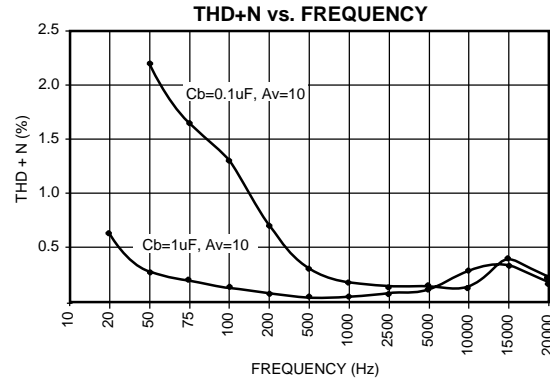
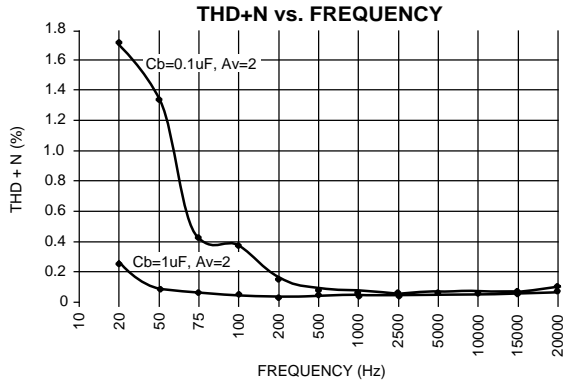

Preliminary Information

Notes:

Preliminary Information

Mechanical Dimensions – 8-Lead SOIC Package

Symbol	Inches		Millimeters		Notes
	Min.	Max.	Min.	Max.	
A	.053	.069	1.35	1.75	
A1	.004	.010	0.10	0.25	
B	.013	.020	0.33	0.51	
C	.008	.010	0.20	0.25	5
D	.189	.197	4.80	5.00	2
E	.150	.158	3.81	4.01	2
e	.050 BSC		1.27 BSC		
H	.228	.244	5.79	6.20	
h	.010	.020	0.25	0.50	
L	.016	.050	0.40	1.27	3
N	8		8		6
α	0°	8°	0°	8°	
ccc	—	.004	—	0.10	

Notes:

1. Dimensioning and tolerancing per ANSI Y14.5M-1982.
2. "D" and "E" do not include mold flash. Mold flash or protrusions shall not exceed .010 inch (0.25mm).
3. "L" is the length of terminal for soldering to a substrate.
4. Terminal numbers are shown for reference only.
5. "C" dimension does not include solder finish thickness.
6. Symbol "N" is the maximum number of terminals.

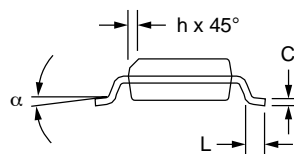
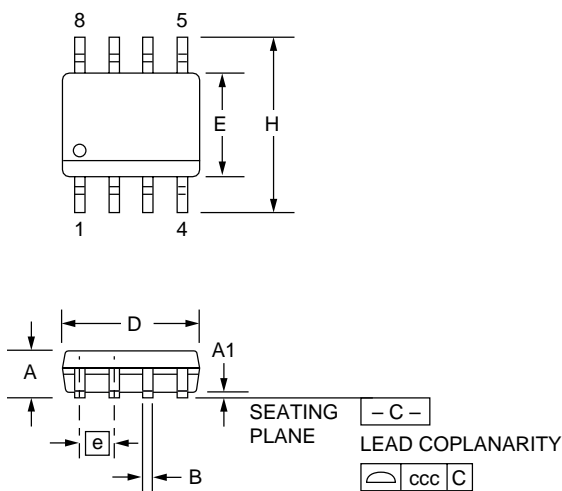

Preliminary Information

Ordering Information

Product Number	Package
RC4861M	8 pin SOIC

Preliminary Information

LIFE SUPPORT POLICY

FAIRCHILD'S PRODUCTS ARE NOT AUTHORIZED FOR USE AS CRITICAL COMPONENTS IN LIFE SUPPORT DEVICES OR SYSTEMS WITHOUT THE EXPRESS WRITTEN APPROVAL OF THE PRESIDENT OF FAIRCHILD SEMICONDUCTOR CORPORATION. As used herein:

1. Life support devices or systems are devices or systems which, (a) are intended for surgical implant into the body, or (b) support or sustain life, and (c) whose failure to perform when properly used in accordance with instructions for use provided in the labeling, can be reasonably expected to result in a significant injury of the user.
2. A critical component in any component of a life support device or system whose failure to perform can be reasonably expected to cause the failure of the life support device or system, or to affect its safety or effectiveness.