

RCV420

Precision 4mA to 20mA CURRENT LOOP RECEIVER

FEATURES

- COMPLETE 4-20mA TO 0-5V CONVERSION
- INTERNAL SENSE RESISTORS
- PRECISION 10V REFERENCE
- BUILT-IN LEVEL-SHIFTING
- ±40V COMMON-MODE INPUT RANGE
- 0.1% OVERALL CONVERSION ACCURACY
- HIGH NOISE IMMUNITY: 86dB CMR

APPLICATIONS

- PROCESS CONTROL
- INDUSTRIAL CONTROL
- FACTORY AUTOMATION
- DATA ACQUISITION
- SCADA
- RTUs
- ESD
- MACHINE MONITORING

DESCRIPTION

The RCV420 is a precision current-loop receiver designed to convert a 4–20mA input signal into a 0–5V output signal. As a monolithic circuit, it offers high reliability at low cost. The circuit consists of a premium grade operational amplifier, an on-chip precision resistor network, and a precision 10V reference. The RCV420 features 0.1% overall conversion accuracy, 86dB CMR, and ±40V common-mode input range.

The circuit introduces only a 1.5V drop at full scale, which is useful in loops containing extra instrument burdens or in intrinsically safe applications where

transmitter compliance voltage is at a premium. The 10V reference provides a precise 10V output with a typical drift of 5ppm/°C.

The RCV420 is completely self-contained and offers a highly versatile function. No adjustments are needed for gain, offset, or CMR. This provides three important advantages over discrete, board-level designs: 1) lower initial design cost, 2) lower manufacturing cost, and 3) easy, cost-effective field repair of a precision circuit.

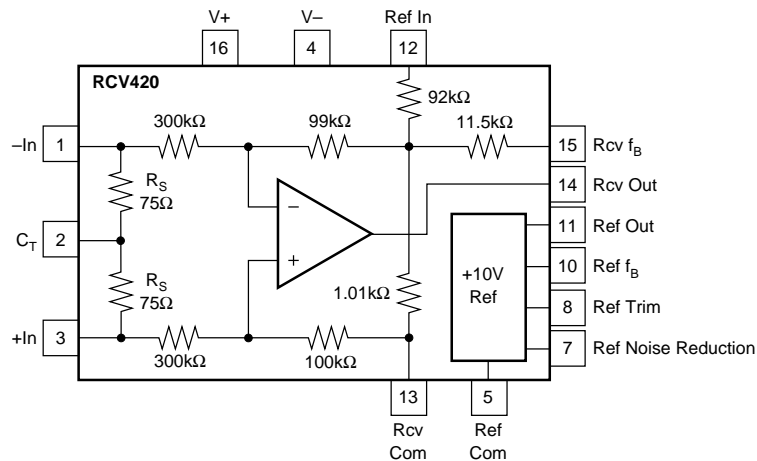

International Airport Industrial Park • Mailing Address: PO Box 11400, Tucson, AZ 85734 • Street Address: 6730 S. Tucson Blvd., Tucson, AZ 85706 • Tel: (520) 746-1111 • Twx: 910-952-1111
 Internet: <http://www.burr-brown.com/> • FAXLine: (800) 548-6133 (US/Canada Only) • Cable: BBRCORP • Telex: 066-6491 • FAX: (520) 889-1510 • Immediate Product Info: (800) 548-6132

SPECIFICATIONS

ELECTRICAL

At T = +25°C and V_S = ±15V, unless otherwise noted.

CHARACTERISTICS	RCV420KP, JP			UNITS
	MIN	TYP	MAX	
GAIN				
Initial		0.3125		V/mA
Error		0.05	0.15	% of span
Error—JP Grade			0.25	% of span
vs Temp		15		ppm/°C
Nonlinearity ⁽¹⁾		0.0002	0.002	% of span
OUTPUT				
Rated Voltage (I _O = +10mA, -5mA)	10	12		V
Rated Current (E _O = 10V)	+10, -5			mA
Impedance (Differential)		0.01		Ω
Current Limit (To Common)		+49, -13		mA
Capacitive Load (Stable Operation)		1000		pF
INPUT				
Sense Resistance	74.25	75	75.75	Ω
Input Impedance (Common-Mode)		200		kΩ
Common-Mode Voltage			±40	V
CMR ⁽²⁾	70	80		dB
vs Temp (DC) (T _A = T _{MIN} to T _{MAX})		76		dB
AC 60Hz		80		dB
OFFSET VOLTAGE (RTO)⁽³⁾				
Initial			1	mV
vs Temp		10		μV/°C
vs Supply (±11.4V to ±18V)	74	90		dB
vs Time		200		μV/mo
ZERO ERROR⁽⁴⁾				
Initial		0.025	0.075	% of span
Initial—JP Grade			0.15	% of span
vs Temp		10		ppm of span/°C
OUTPUT NOISE VOLTAGE				
f _B = 0.1Hz to 10Hz		50		μVp-p
f _O = 10kHz		800		nV/√Hz
DYNAMIC RESPONSE				
Gain Bandwidth		150		kHz
Full Power Bandwidth		30		kHz
Slew Rate		1.5		V/μs
Settling Time (0.01%)		10		μs
VOLTAGE REFERENCE				
Initial	9.99		10.01	V
Trim Range ⁽⁵⁾		±4		%
vs Temp		5		ppm/°C
vs Supply (±11.4V to ±18V)		0.0002		%/V
vs Output Current (I _O = 0 to +10mA)		0.0002		%/mA
vs Time		15		ppm/kHz
Noise (0.1Hz to 10Hz)		5		μVp-p
Output Current	+10, -2			mA
POWER SUPPLY				
Rated		±15		V
Voltage Range ⁽⁶⁾	-5, +11.4		±18	V
Quiescent Current (V _O = 0V)		3	4	mA
TEMPERATURE RANGE				
Specification	0		+70	°C
Operation	-25		+85	°C
Storage	-40		+85	°C
Thermal Resistance, θ _{JA}		80		°C/W

NOTES: (1) Nonlinearity is the max peak deviation from best fit straight line. (2) With 0 source impedance on Rcv Com pin. (3) Referred to output with all inputs grounded including Ref In. (4) With 4mA input signal and Voltage Reference connected (includes V_{OS}, Gain Error, and Voltage Reference Errors). (5) External trim slightly affects drift. (6) I_O Ref = 5mA, I_O Rcv = 2mA.

PIN CONFIGURATION

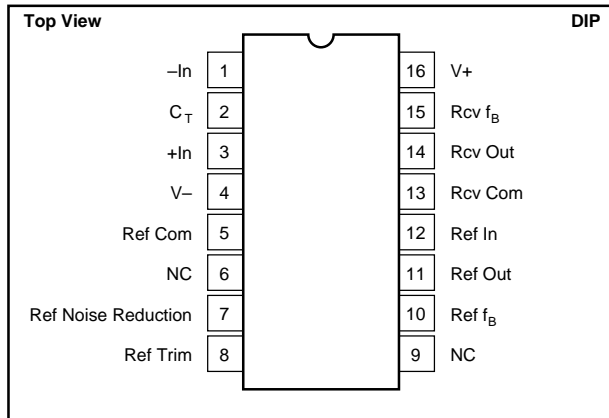

ABSOLUTE MAXIMUM RATINGS⁽¹⁾

Supply	±22V
Input Current, Continuous	40mA
Input Current Momentary, 0.1s	250mA, 1% Duty Cycle
Common-Mode Input Voltage, Continuous	±40V
Lead Temperature (soldering, 10s)	+300°C
Output Short Circuit to Common (Rcv and Ref)	Continuous

NOTE: (1) Stresses above these ratings may cause permanent damage.

PACKAGE INFORMATION

PRODUCT	PACKAGE	PACKAGE DRAWING NUMBER ⁽¹⁾
RCV420KP	16-Pin Plastic DIP	180
RCV420JP	16-Pin Plastic DIP	180

NOTE: (1) For detailed drawing and dimension table, please see end of data sheet, or Appendix C of Burr-Brown IC Data Book.

ORDERING INFORMATION

PRODUCT	PERFORMANCE GRADE	PACKAGE
RCV420KP	0°C to +70°C	16-Pin Plastic DIP
RCV420JP	0°C to +70°C	16-Pin Plastic DIP

The information provided herein is believed to be reliable; however, BURR-BROWN assumes no responsibility for inaccuracies or omissions. BURR-BROWN assumes no responsibility for the use of this information, and all use of such information shall be entirely at the user's own risk. Prices and specifications are subject to change without notice. No patent rights or licenses to any of the circuits described herein are implied or granted to any third party. BURR-BROWN does not authorize or warrant any BURR-BROWN product for use in life support devices and/or systems.

TYPICAL PERFORMANCE CURVES

At $T_A = +25^\circ\text{C}$, $V_S = \pm 15\text{V}$, unless otherwise noted.

STEP RESPONSE
NO LOAD

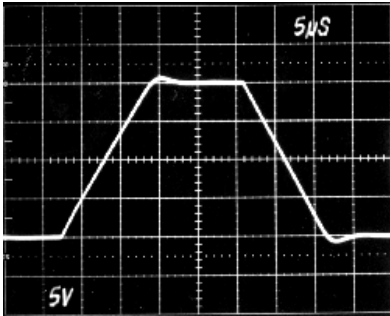

SMALL SIGNAL RESPONSE
NO LOAD

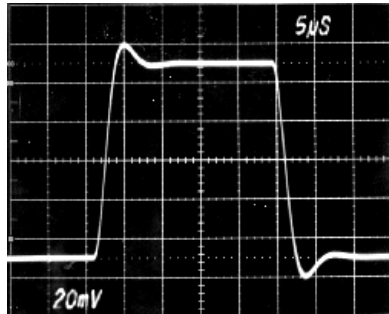

SMALL SIGNAL RESPONSE
 $R_L = \infty$, $C_L = 1000\text{pF}$

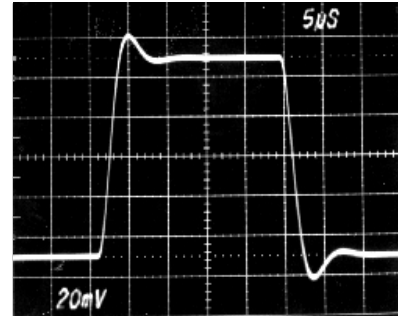

POSITIVE COMMON-MODE VOLTAGE RANGE
vs POSITIVE POWER SUPPLY VOLTAGE

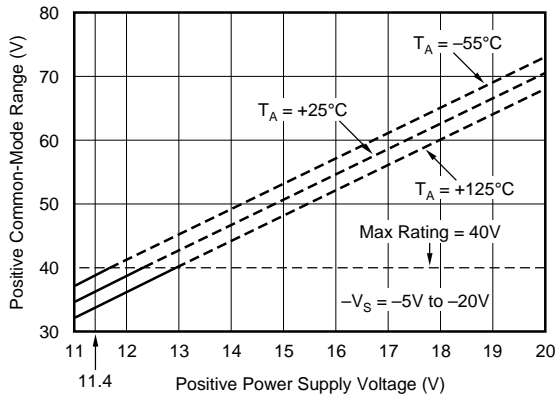

NEGATIVE COMMON-MODE VOLTAGE RANGE
vs NEGATIVE POWER SUPPLY VOLTAGE

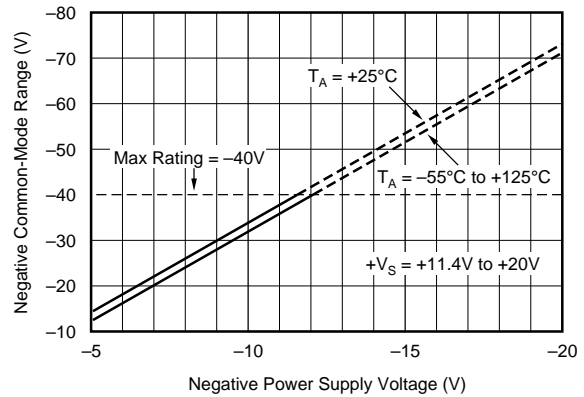

COMMON-MODE REJECTION
vs FREQUENCY

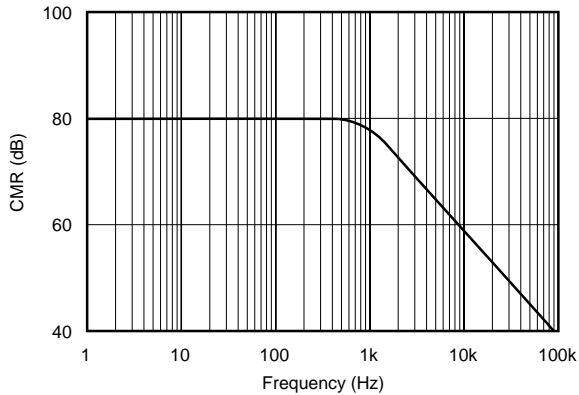

POWER-SUPPLY REJECTION
vs FREQUENCY

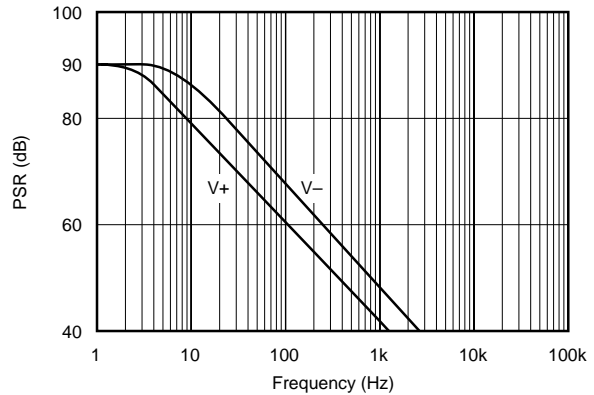

THEORY OF OPERATION

Refer to the figure on the first page. For 0 to 5V output with 4–20mA input, the required transimpedance of the circuit is:

$$V_{OUT}/I_{IN} = 5V/16mA = 0.3125V/mA.$$

To achieve the desired output (0V for 4mA and 5V for 20mA), the output of the amplifier must be offset by an amount:

$$V_{OS} = -(4mA)(0.3125V/mA) = -1.25V.$$

The input current signal is connected to either +In or –In, depending on the polarity of the signal, and returned to ground through the center tap, C_T . The balanced input—two matched 75Ω sense resistors, R_S —provides maximum rejection of common-mode voltage signals on C_T and true differential current-to-voltage conversion. The sense resistors convert the input current signal into a proportional voltage, which is amplified by the differential amplifier. The voltage gain of the amplifier is:

$$A_D = 5V/(16mA)(75\Omega) = 4.1667V/V.$$

The tee network in the feedback path of the amplifier provides a summing junction used to generate the required –1.25V offset voltage. The input resistor network provides high-input impedance and attenuates common-mode input voltages to levels suitable for the operational amplifier’s common-mode signal capabilities.

BASIC POWER SUPPLY AND SIGNAL CONNECTIONS

Figure 1 shows the proper connections for power supply and signal. Both supplies should be decoupled with $1\mu F$ tantalum capacitors as close to the amplifier as possible. To avoid gain and CMR errors introduced by the external circuit, connect grounds as indicated, being sure to minimize ground resistance. The input signal should be connected to either +In or –In, depending on its polarity, and returned through the center tap, C_T . The output of the voltage reference, Ref Out, should be connected to Ref In for the

necessary level shifting. If the Ref In pin is not used for level shifting, then it must be grounded to maintain high CMR.

GAIN AND OFFSET ADJUSTMENT

Figure 2 shows the circuit for adjusting the RCV420 gain. Increasing the gain of the RCV420 is accomplished by inserting a small resistor in the feedback path of the amplifier. Increasing the gain using this technique results in CMR degradation, and therefore, gain adjustments should be kept as small as possible. For example, a 1% increase in gain is typically realized with a 125Ω resistor, which degrades CMR by about 6dB.

A decrease in gain can be achieved by placing matched resistors in parallel with the sense resistors, also shown in Figure 2. The adjusted gain is given by the following expression

$$V_{OUT}/I_{IN} = 0.3125 \times R_X/(R_X + R_S).$$

A 1% decrease in gain can be achieved with a $7.5k\Omega$ resistor. It is important to match the parallel resistance on each sense resistor to maintain high CMR. The TCR mismatch between the two external resistors will effect gain error drift and CMR drift.

There are two methods for nulling the RCV420 output offset voltage. The first method applies to applications using the internal 10V reference for level shifting. For these applica-

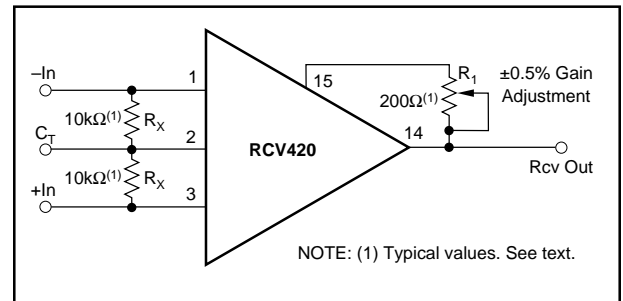

FIGURE 2. Optional Gain Adjustment.

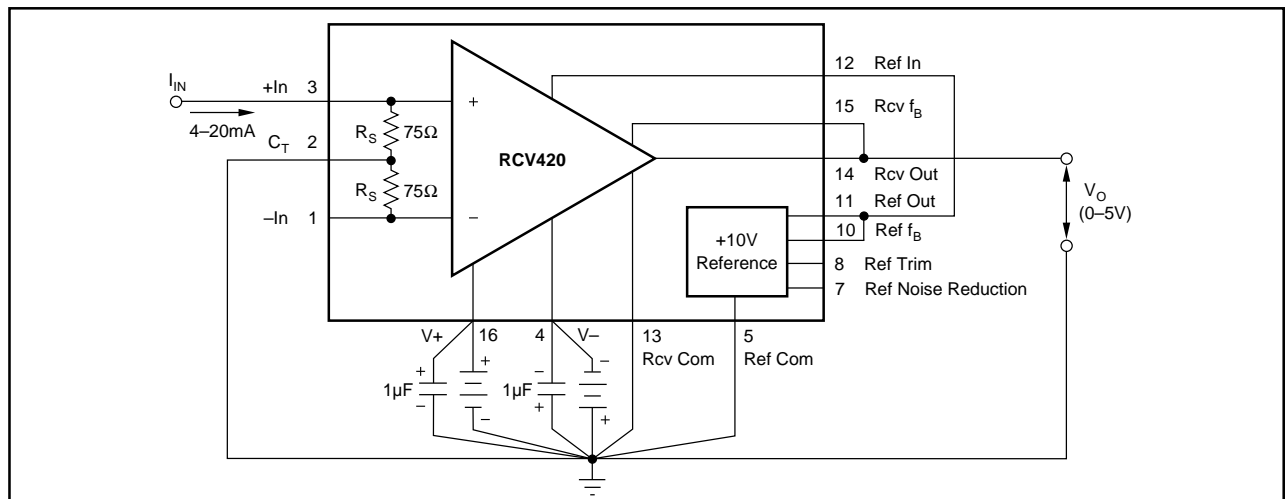

FIGURE 1. Basic Power Supply and Signal Connections.

tions, the voltage reference output trim procedure can be used to null offset errors at the output of the RCV420. The voltage reference trim circuit is discussed under “Voltage Reference.”

When the voltage reference is not used for level shifting or when large offset adjustments are required, the circuit in Figure 3 can be used for offset adjustment. A low impedance on the Rcv Com pin is required to maintain high CMR.

ZERO ADJUSTMENT

Level shifting the RCV420 output voltage can be achieved using either the Ref In pin or the Rcv Com pin. The disadvantage of using the Ref In pin is that there is an 8:1 voltage attenuation from this pin to the output of the RCV420. Thus, use the Rcv Com pin for large offsets, because the voltage on this pin is seen directly at the output. Figure 4 shows the circuit used to level-shift the output of the RCV420

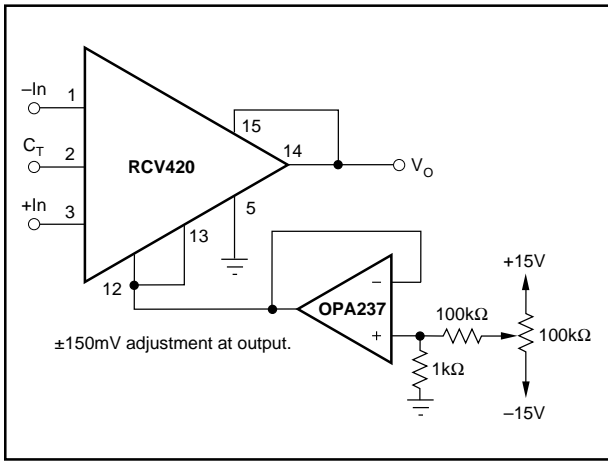

FIGURE 3. Optional Output Offset Nulling Using External Amplifier.

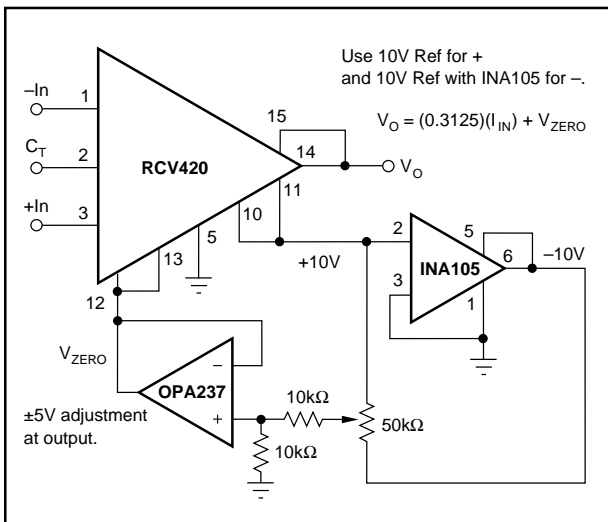

FIGURE 4. Optional Zero Adjust Circuit.

using the Rcv Com pin. It is important to use a low-output impedance amplifier to maintain high CMR. With this method of zero adjustment, the Ref In pin must be connected to the Rcv Com pin.

MAINTAINING COMMON-MODE REJECTION

Two factors are important in maintaining high CMR: (1) resistor matching and tracking (the internal resistor network does this) and (2) source impedance. CMR depends on the accurate matching of several resistor ratios. The high accuracies needed to maintain the specified CMR and CMR temperature coefficient are difficult and expensive to reliably achieve with discrete components. Any resistance imbalance introduced by external circuitry directly affects CMR. These imbalances can occur by: mismatching sense resistors when gain is decreased, adding resistance in the feedback path when gain is increased, and adding series resistance on the Rcv Com pin.

The two sense resistors are laser-trimmed to typically match within 0.01%; therefore, when adding parallel resistance to decrease gain, take care to match the parallel resistance on each sense resistor. To maintain high CMR when increasing the gain of the RCV420, keep the series resistance added to the feedback network as small as possible. Whether the Rcv Com pin is grounded or connected to a voltage reference for level shifting, keep the series resistance on this pin as low as possible. For example, a resistance of 20Ω on this pin degrades CMR from 86dB to approximately 80dB. For applications requiring better than 86dB CMR, the circuit shown in Figure 5 can be used to adjust CMR.

PROTECTING THE SENSE RESISTOR

The 75Ω sense resistors are designed for a maximum continuous current of 40mA, but can withstand as much as 250mA for up to 0.1s (see absolute maximum ratings). There are several ways to protect the sense resistor from

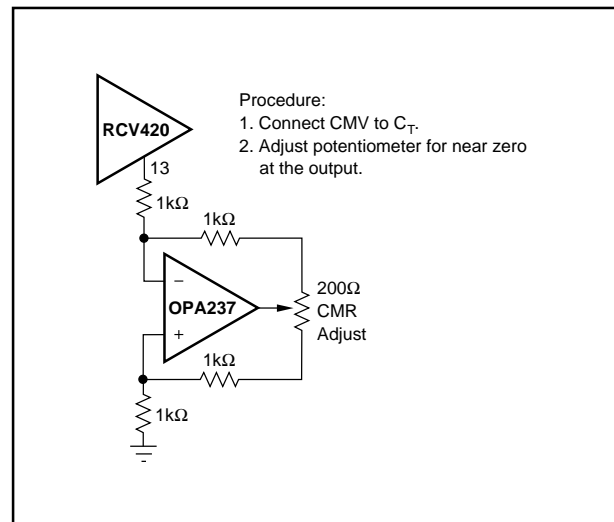

FIGURE 5. Optional Circuit for Externally Trimming CMR.

overcurrent conditions exceeding these specifications. Refer to Figure 6. The simplest and least expensive method is a resistor as shown in Figure 6a. The value of the resistor is determined from the expression

$$R_X = V_{CC}/40\text{mA} - 75\Omega$$

and the full scale voltage drop is

$$V_{RX} = 20\text{mA} \times R_X.$$

For a system operating off of a 32V supply $R_X = 725\Omega$ and $V_{RX} = 14.5\text{V}$. In applications that cannot tolerate such a large voltage drop, use circuits 6b or 6c. In circuit 6b a power JFET and source resistor are used as a current limit. The 200Ω potentiometer, R_X , is adjusted to provide a current limit of approximately 30mA. This circuit introduces a 1–4V drop at full scale. If only a very small series voltage drop at full scale can be tolerated, then a 0.032A series 217 fast-acting fuse should be used, as shown in Figure 6c.

For automatic fold-back protection, use the circuit shown in Figure 15.

VOLTAGE REFERENCE

The RCV420 contains a precision 10V reference. Figure 8 shows the circuit for output voltage adjustment. Trimming the output will change the voltage drift by approximately $0.007\text{ppm}/^\circ\text{C}$ per mV of trimmed voltage. Any mismatch in TCR between the two sides of the potentiometer will also affect drift, but the effect is divided by approximately 5. The trim range of the voltage reference using this method is typically $\pm 400\text{mV}$. The voltage reference trim can be used to trim offset errors at the output of the RCV420. There is an 8:1 voltage attenuation from Ref In to Rcv Out, and thus the trim range at the output of the receiver is typically $\pm 50\text{mV}$.

The high-frequency noise (to 1MHz) of the voltage reference is typically 1mVp-p . When the voltage reference is used for level shifting, its noise contribution at the output of the receiver is typically $125\mu\text{Vp-p}$ due to the 8:1 attenuation from Ref In to Rcv Out. The reference noise can be reduced by connecting an external capacitor between the Noise Reduction pin and ground. For example, $0.1\mu\text{F}$ capacitor reduces the high-frequency noise to about $200\mu\text{Vp-p}$ at the output of the reference and about $25\mu\text{Vp-p}$ at the output of the receiver.

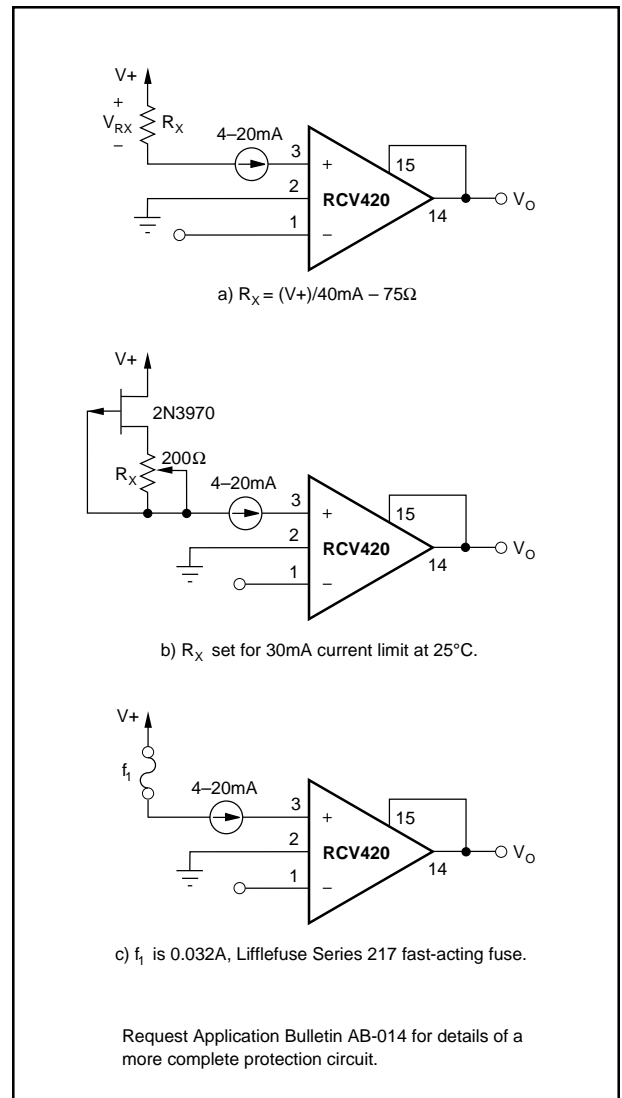

FIGURE 6. Protecting the Sense Resistors.

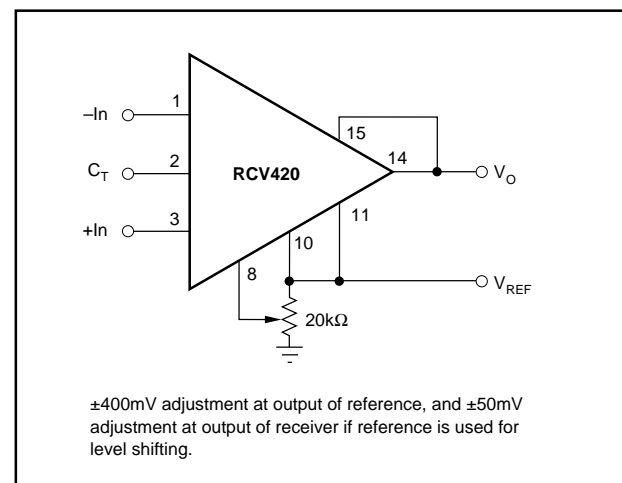

FIGURE 7. Optional Voltage Reference External Trim Circuit.

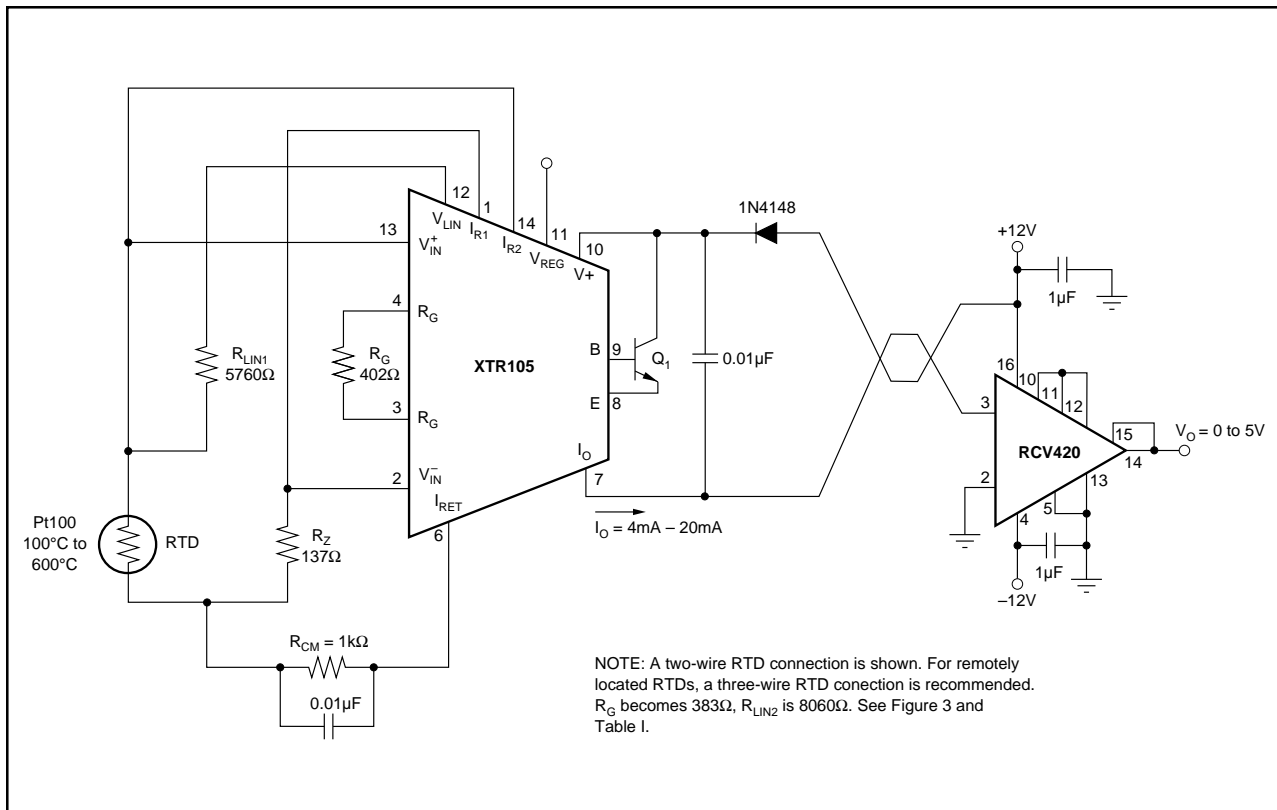

FIGURE 8. RCV420 Used in Conjunction with XTR101 to Form a Complete Solution for 4-20mA Loop.

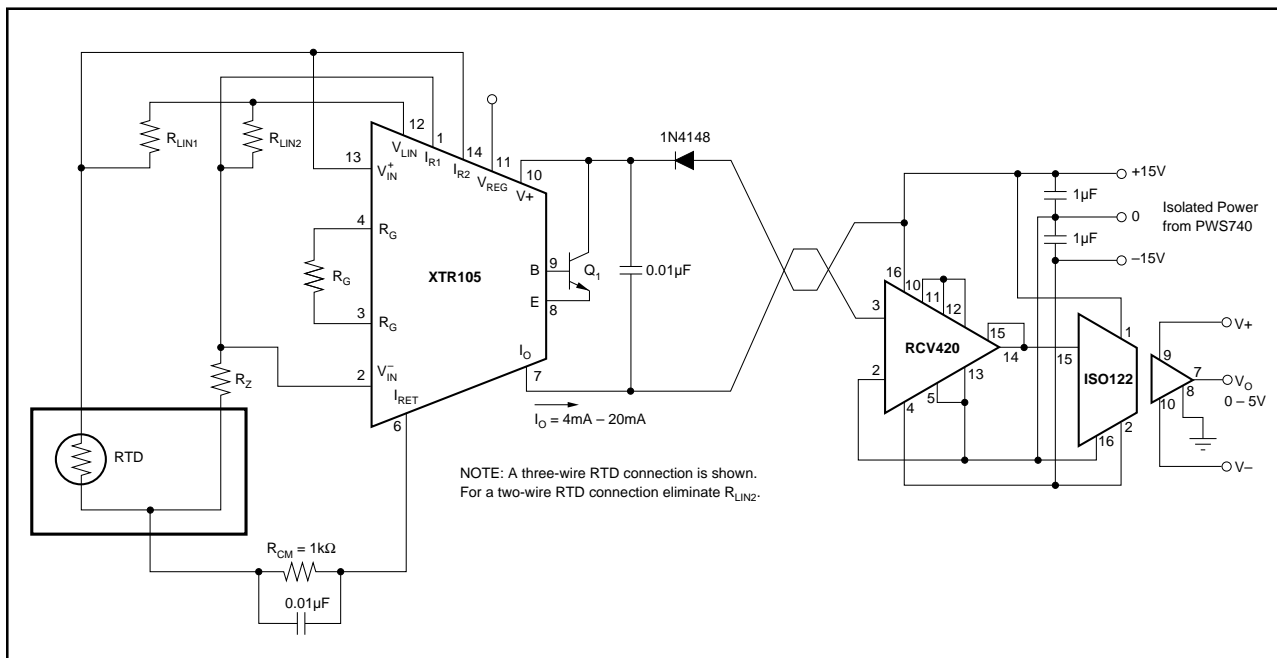
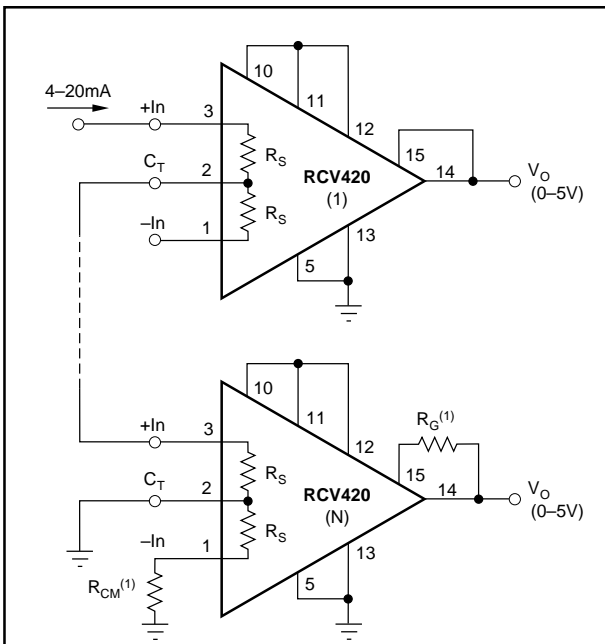

FIGURE 9. Isolated 4-20mA Instrument Loop (RTD shown).



NOTE: (1) R_{CM} and R_G are used to provide a first order correction of CMR and Gain Error, respectively. Table 1 gives typical resistor values for R_{CM} and R_G when as many as three RCV420s are stacked. Table II gives typical CMR and Gain Error with no correction. Further improvement in CMR and Gain Error can be achieved using a 500k Ω potentiometer for R_{CM} and a 100 Ω potentiometer for R_G .

RCV420	R_{CM} (k Ω)	R_G (Ω)
1	∞	0
2	200	7
3	67	23

TABLE 1. Typical Values for R_{CM} and R_G .

RCV420	CMR (dB)	GAIN ERROR %
1	94	0.025
2	68	0.075
3	62	0.200

TABLE II. Typical CMR and Gain Error Without Correction.

FIGURE 10. Series 4-20mA Receivers.

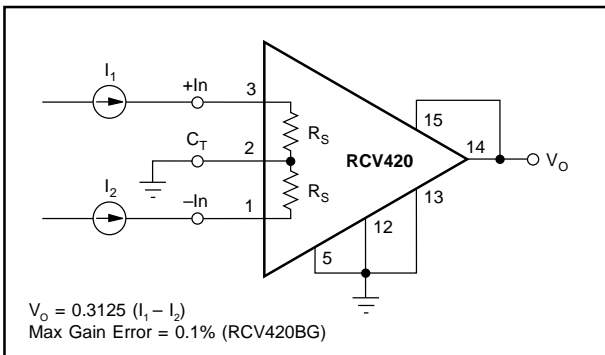

FIGURE 11. Differential Current-to-Voltage Converter.

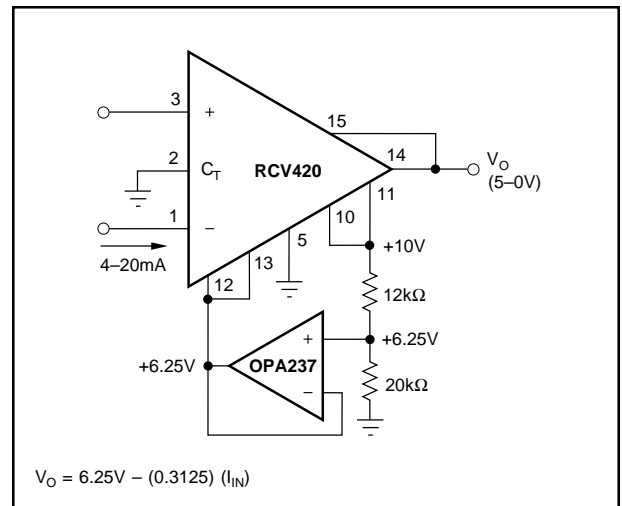

FIGURE 12. 4-20mA to 5-0V Conversion.

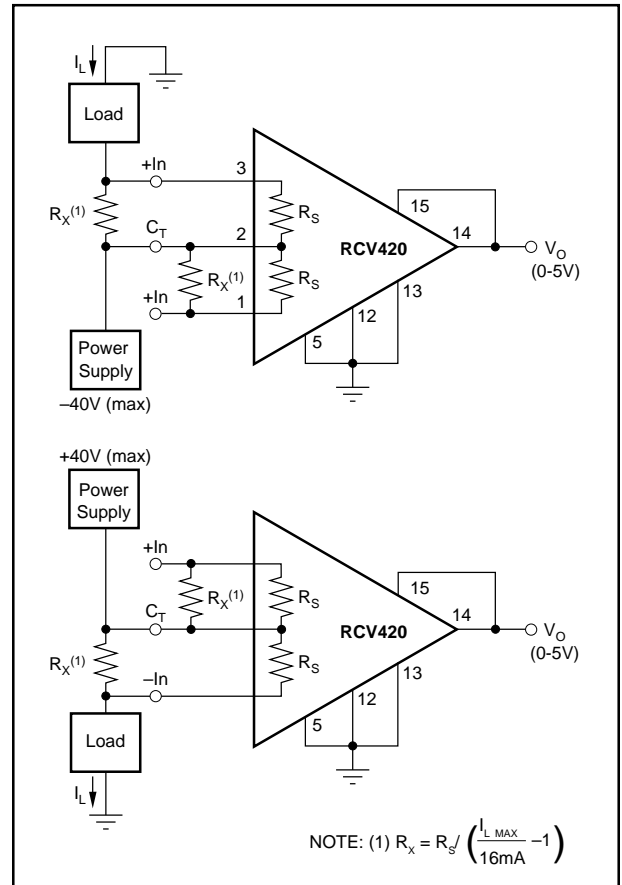

FIGURE 13. Power Supply Current Monitor Circuit.

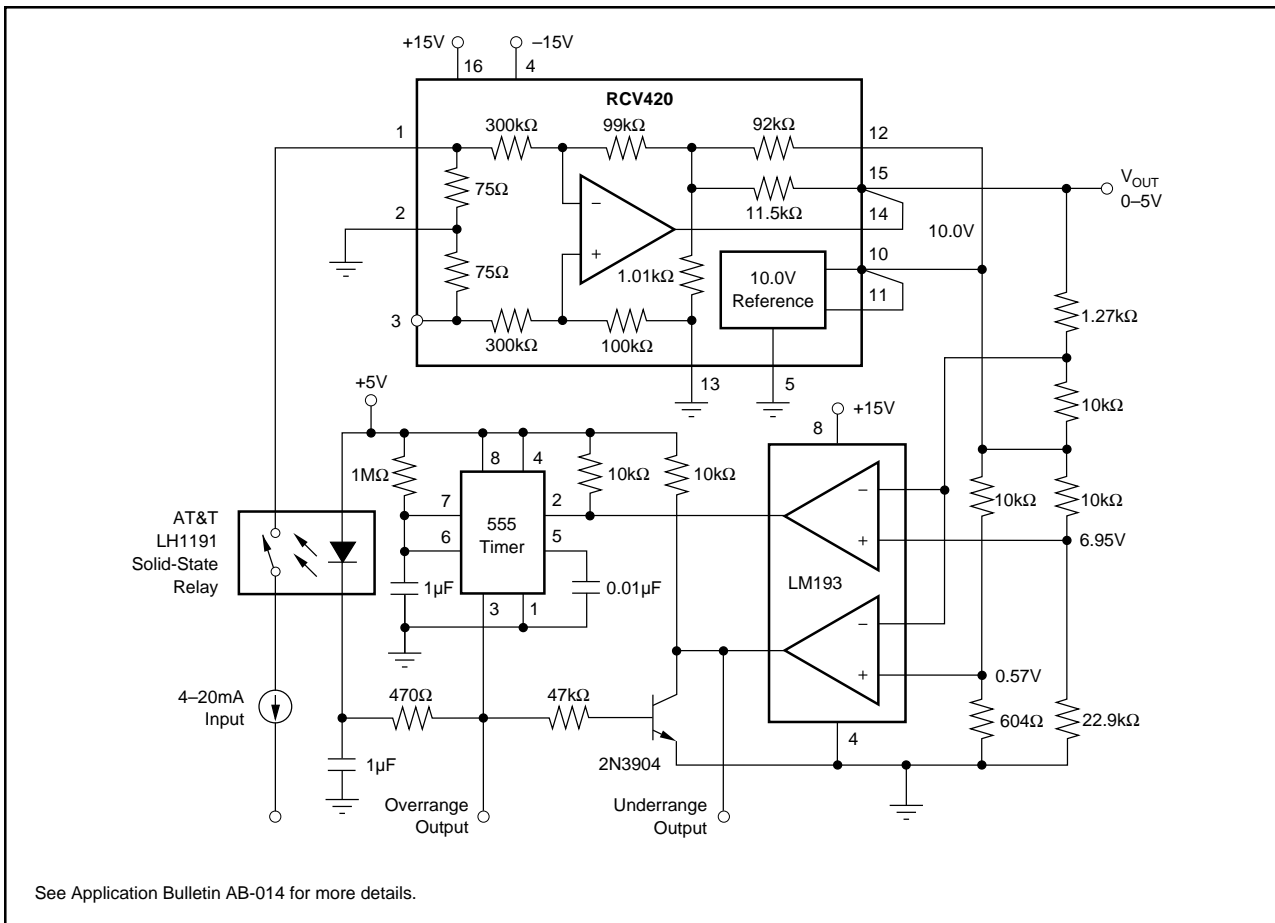

FIGURE 14. 4-20mA Current Loop Receiver with Input Overload Protection.

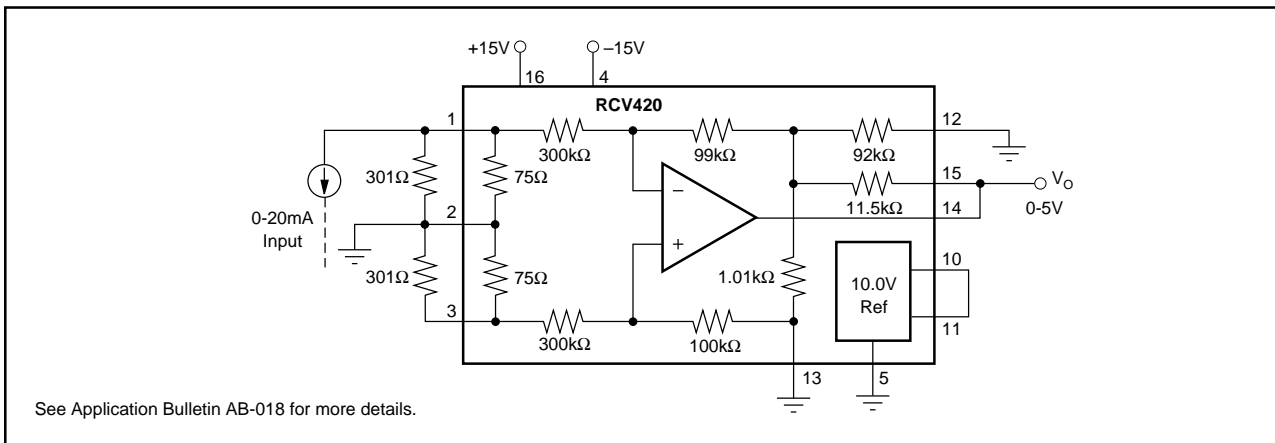

FIGURE 15. 0-20mA/0-5V Receiver Using RCV420.

IMPORTANT NOTICE

Texas Instruments and its subsidiaries (TI) reserve the right to make changes to their products or to discontinue any product or service without notice, and advise customers to obtain the latest version of relevant information to verify, before placing orders, that information being relied on is current and complete. All products are sold subject to the terms and conditions of sale supplied at the time of order acknowledgment, including those pertaining to warranty, patent infringement, and limitation of liability.

TI warrants performance of its semiconductor products to the specifications applicable at the time of sale in accordance with TI's standard warranty. Testing and other quality control techniques are utilized to the extent TI deems necessary to support this warranty. Specific testing of all parameters of each device is not necessarily performed, except those mandated by government requirements.

Customers are responsible for their applications using TI components.

In order to minimize risks associated with the customer's applications, adequate design and operating safeguards must be provided by the customer to minimize inherent or procedural hazards.

TI assumes no liability for applications assistance or customer product design. TI does not warrant or represent that any license, either express or implied, is granted under any patent right, copyright, mask work right, or other intellectual property right of TI covering or relating to any combination, machine, or process in which such semiconductor products or services might be or are used. TI's publication of information regarding any third party's products or services does not constitute TI's approval, warranty or endorsement thereof.