

# 8-LINE TO 1-LINE DATA SELECTOR/MULTIPLEXER

# S54152

S54152-W

DIGITAL 54/74 TTL SERIES

## DESCRIPTION

The S54152 is a one-of-eight data selector which performs parallel to serial data conversion. The S54152 is identical to the S54152 with the exclusion of the true output and strobe. It is available in the 14-pin flatpak only.

## LOGIC DIAGRAM

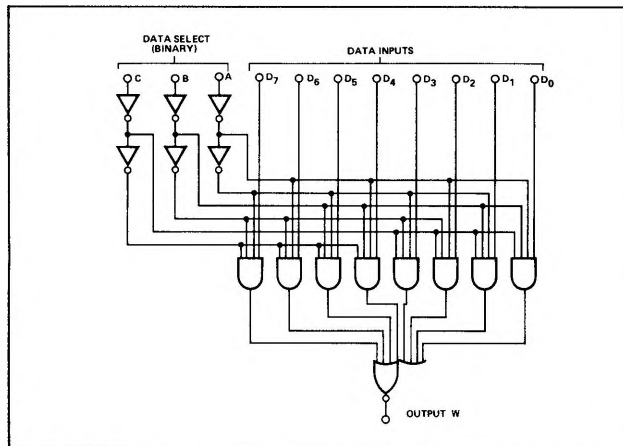

## PIN CONFIGURATIONS

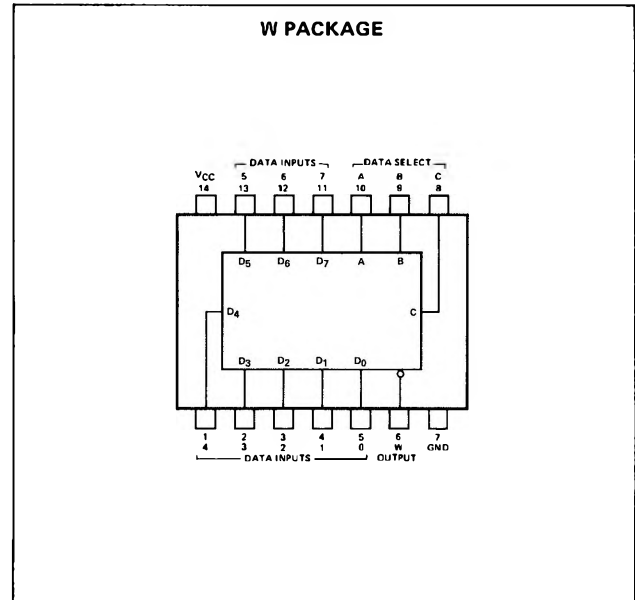

## TRUTH TABLE

INPUTS												OUTPUTS	
C	B	A	STROBE	D <sub>0</sub>	D <sub>1</sub>	D <sub>2</sub>	D <sub>3</sub>	D <sub>4</sub>	D <sub>5</sub>	D <sub>6</sub>	D <sub>7</sub>	Y(1)	W
X	X	X	1	X	X	X	X	X	X	X	X	0	1
0	0	0	0	0	X	X	X	X	X	X	X	0	1
0	0	0	0	1	X	X	X	X	X	X	X	1	0
0	0	1	0	X	0	X	X	X	X	X	X	0	1
0	0	1	0	X	1	X	X	X	X	X	X	1	0
0	1	0	0	X	X	0	X	X	X	X	X	0	1
0	1	0	0	X	X	1	X	X	X	X	X	1	0
0	1	1	0	X	X	X	0	X	X	X	X	0	1
0	1	1	0	X	X	X	1	X	X	X	X	1	0
1	0	0	0	X	X	X	X	0	X	X	X	0	1
1	0	0	0	X	X	X	X	1	X	X	X	1	0
1	0	1	0	X	X	X	X	X	0	X	X	0	1
1	0	1	0	X	X	X	X	X	1	X	X	1	0
1	1	0	0	X	X	X	X	X	X	0	X	0	1
1	1	0	0	X	X	X	X	X	X	1	X	1	0
1	1	1	0	X	X	X	X	X	X	X	0	0	1
1	1	1	0	X	X	X	X	X	X	X	1	1	0

When used to indicate an input, X = Irrelevant.

## RECOMMENDED OPERATING CONDITIONS

	MIN	NOM	MAX	UNIT
Supply Voltage V <sub>CC</sub> : S54152 Circuits	4.5	5	5.5	V
Normalized Fan-Out from each Output, N:			10	
			20	



## ELECTRICAL CHARACTERISTICS (over recommended operating free-air temperature range unless otherwise noted)

PARAMETER		TEST CONDITIONS *	MIN	TYP **	MAX	UNIT
$V_{in(1)}$	Input voltage required to ensure logical 1 at any input terminal	$V_{CC} = \text{MIN}$	2			V
$V_{in(0)}$	Input voltage required to ensure logical 0 at any input terminal	$V_{CC} = \text{MIN}$			0.8	V
$V_{out(1)}$	Logical 1 output voltage	$V_{CC} = \text{MIN}, V_{in(1)} = 2V, V_{in(0)} = 0.8V,$ $I_{load} = -800\mu A$	2.4			V
$V_{out(0)}$	Logical 0 output voltage	$V_{CC} = \text{MIN}, V_{in(1)} = 2V, V_{in(0)} = 0.8V,$ $I_{sink} = 16mA$			0.4	V
$I_{in(1)}$	Logical 1 level input (each input)	$V_{CC} = \text{MAX}, V_{in} = 2.4V$			40	$\mu A$
$I_{in(1)}$	Logical 1 level input (each input)	$V_{CC} = \text{MAX}, V_{in} = 5.5V$			1	mA
$I_{in(0)}$	Logical 0 level input current (each input)	$V_{CC} = \text{MAX}, V_{in} = 0.4V$			-1.6	mA
$I_{OS}$	Short circuit output current †	$V_{CC} = \text{MAX},$ $V_{out} = 0$	-20		-55	mA
$I_{OS}$	Short circuit output current †	$V_{CC} = \text{MAX}, V_{in} = 4.5V$	-18		-55	mA
$I_{CC}$	Supply current	$V_{CC} = \text{MAX}, V_{in} = 4.5V$		26	43	mA

SWITCHING CHARACTERISTICS,  $V_{CC} = 5V, T_A = 25^\circ C, N = 10$ 

PARAMETER	FROM (INPUT)	TO (OUTPUT)	TEST CONDITIONS	MIN	TYP	MAX	UNIT
$t_{pd0}$	A,B,orC(4 levels)	Y	$C_L = 15pF, R_L = 400\Omega$		20	30	ns
$t_{pd1}$	A,B,orC(4 levels)	Y			35	52	ns
$t_{pd0}$	A,B,C,orD(3 levels)	W			22	33	ns
$t_{pd1}$	A,B,C,orD(3 levels)	W			23	35	ns
$t_{pd0}$	STROBE	Y			19	30	ns
$t_{pd1}$	STROBE	Y			35	52	ns
$t_{pd0}$	STROBE	W			21	30	ns
$t_{pd1}$	STROBE	W			15.5	24	ns
$t_{pd0}$	D <sub>0</sub> thru D <sub>7</sub>	Y			16	24	ns
$t_{pd1}$	D <sub>0</sub> thru D <sub>7</sub>	Y			19	29	ns
$t_{pd0}$	E <sub>0</sub> thru E <sub>15</sub>	W			8.5	14	ns
$t_{pd1}$	E <sub>0</sub> thru E <sub>15</sub>	W			13	20	ns

\* For conditions shown as MIN or MAX, use the appropriate value specified under recommended operating conditions for the applicable circuit type.

\*\* All typical values are at  $V_{CC} = 5V, T_A = 25^\circ C$ .

† Not more than one output should be shorted at a time.