

MuxIt™ SERIALIZER-TRANSMITTER

FEATURES

- **A Member of the MuxIt™ Serializer-Deserializer Building-Block Chip Family**
- **Supports Serialization of up to 10 Bits of Parallel Data Input at Rates up to 200 Mbps**
- **PLL Lock/Valid Input Provided to Enable Link Data Transfers**
- **Cascadable With Additional SN65LVDS151 MuxIt Serializer-Transmitters for Wider Parallel Input Data Channel Widths**
- **LVDS Compatible Differential Inputs and Outputs Meet or Exceed the Requirements of ANSI TIA/EIA-644-A**
- **LVDS Inputs and Outputs ESD Protection Exceeds 12 kV HBM**
- **LVTTL Compatible Inputs for Lock/Valid, Enables, and Parallel Data Inputs Are 5-V Tolerant**
- **Operates With 3.3 V Supply**
- **Packaged in 32-Pin DA Thin Shrink Small-Outline Package With 26 Mil Terminal Pitch**

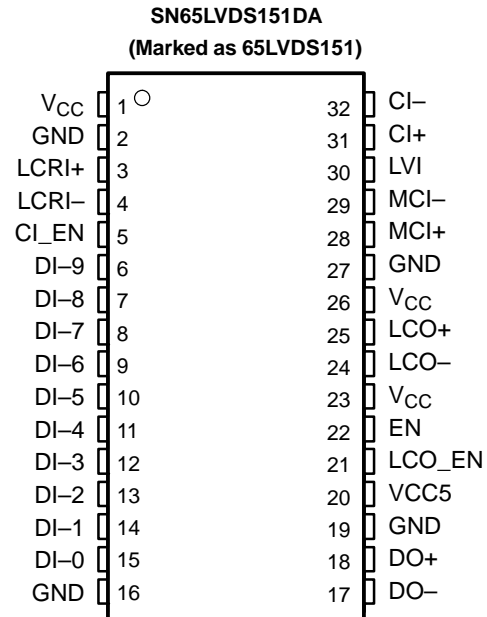

DESCRIPTION

MuxIt is a family of general-purpose, multiple-chip building blocks for implementing parallel data serializers and deserializers. The system allows for wide parallel data to be transmitted through a reduced number of transmission lines over distances greater than can be achieved with a single-ended (e.g., LVTTL or LVCMOS) data interface. The number of bits multiplexed per transmission line is user-selectable and allows for higher transmission efficiencies than with existing fixed ratio solutions. MuxIt utilizes the LVDS (TIA/EIA-644-A) low voltage differential signaling technology for communications between the data source and data destination.

The MuxIt family initially includes three devices supporting simplex communications: the SN65LVDS150 phase locked loop frequency multiplier, the SN65LVDS151 serializer-transmitter, and the SN65LVDS152 receiver-deserializer.

The SN65LVDS151 consists of a 10-bit parallel-in/serial-out shift register, three LVDS differential transmission line receivers, a pair of LVDS differential transmission line drivers, plus associated input buffers. It accepts up to 10 bits of user data on parallel data inputs (DI-0 → DI-9) and serializes (multiplexes) the data for transmission over an LVDS transmission line link. Two or more SN65LVDS151 units may be connected in series (cascaded) to accommodate wider parallel data paths for higher serialization values. Data is transmitted over the LVDS serial link at M times the input parallel data clock frequency. The multiplexing ratio M, or number of bits per data clock cycle, is programmed on the companion SN65LVDS150 MuxIt programmable PLL frequency multiplier with configuration pins (M1 → M5). The range of multiplexing ratio M supported by the SN65LVDS150 MuxIt programmable PLL frequency multiplier is between 4 and 40. Table 1 shows some of the combinations of LCRI and MCI supported by the SN65LVDS150 MuxIt programmable PLL frequency multiplier.



Please be aware that an important notice concerning availability, standard warranty, and use in critical applications of Texas Instruments semiconductor products and disclaimers thereto appears at the end of this data sheet.

MuxIt is a trademark of Texas Instruments.



These devices have limited built-in ESD protection. The leads should be shorted together or the device placed in conductive foam during storage or handling to prevent electrostatic damage to the MOS gates.

DESCRIPTION (CONTINUED)

Data is parallel loaded into the SN65LVDS151 input latches on the first rising edge of the M-clock input (MCI) signal following a rising edge of the link clock reference input (LCRI). The data is read out serially from the SN65LVDS151 shift registers on the rising edges of the M-clock input (MCI). The lowest order bit of parallel input data, DI-0, is output from DO on the third rising edge of MCI following the rising edge of LCRI. The remaining bits of parallel input data, DI-1 → DI-(M-1) are clocked out sequentially, in ascending order, by subsequent MCI rising edges. The link clock output (LCO) signal rising edge is synchronized to the data output (DO) by an internal circuit clocked by MCI. The LCO signal rising edge follows the first rising edge of MCI after the rising edge of LCRI. Examples of operating waveforms for values of M = 4 and M = 10 are provided in [Table 1](#).

Both the LCRI and MCI signals are intended to be sourced from the SN65LVDS150 MuxIt programmable frequency multiplier. They are carried over LVDS differential connections to minimize skew and jitter. The SN65LVDS151 includes LVDS differential line drivers for both the serialized data output (DO) stream and the link clock output (LCO). The cascade input (CI) is also an LVDS connection, and when it is used it is tied to the DO output of the preceding SN65LVDS151.

An internal power-on reset (POR) and an enable input (EN) control the operation of the SN65LVDS151. When V_{CC} is below 1.5 V, or when EN is low, the device is in a low-power disabled state, and the DO and LCO differential outputs are in a high-impedance state. When V_{CC} is above 3 V and EN is high, the device and the two differential outputs are enabled and operating to specifications. The link clock output enable input (LCO_EN) is used to turn off the LCO output when it is not being used. Cascade input enable (CI_EN) is used to turn off the CI input when it is not being used.

Serialized data bits are output from the DO output, starting in ascending order, from parallel input bit DI-0. The number of serialized data bits output per data clock cycle is determined by the multiplexing ratio M. For values of M less than or equal to 10, the cascade input (CI±) is not used, and only the first M parallel input bits (DI-0 through DI-[M-1]) are used. For values of M greater than 10, all ten parallel input bits (DI-0 through DI-9) are used, and the cascade input is used to shift in the remaining data bits from additional SN65LVDS151 serializers. [Table 2](#) shows which input data bits are used as a function of the multiplier M.

Table 1. Example Combinations of LCRI and MCI Supported by the SN65LVDS150 MuxIt Programmable PLL Frequency Multiplier

M	LCRI, MHz		MCI, MHz	
	MINIMUM	MAXIMUM	MINIMUM	MAXIMUM
4	5	50	20	200
10	5	20	50	200
20	5	10	100	200
40	5	5	200	200

Table 2. Input Data Bits Used as a Function of the Multiplier M

	M = 4	M = 5	M = 6	M = 7	M = 8	M = 9	M = 10	M >10
1 st bit output	DI-0	DI-0	DI-0	DI-0	DI-0	DI-0	DI-0	DI-0
2 nd bit output	DI-1	DI-1	DI-1	DI-1	DI-1	DI-1	DI-1	DI-1
3 rd bit output	DI-2	DI-2	DI-2	DI-2	DI-2	DI-2	DI-2	DI-2
4 th bit output	DI-3	DI-3	DI-3	DI-3	DI-3	DI-3	DI-3	DI-3
5 th bit output	Invalid	DI-4	DI-4	DI-4	DI-4	DI-4	DI-4	DI-4
6 th bit output	Invalid	Invalid	DI-5	DI-5	DI-5	DI-5	DI-5	DI-5
7 th bit output	Invalid	Invalid	Invalid	DI-6	DI-6	DI-6	DI-6	DI-6
8 th bit output	Invalid	Invalid	Invalid	Invalid	DI-7	DI-7	DI-7	DI-7
9 th bit output	Invalid	Invalid	Invalid	Invalid	Invalid	DI-8	DI-8	DI-8
10 th bit output	Invalid	Invalid	Invalid	Invalid	Invalid	Invalid	DI-9	DI-9
11 th + bits output	Invalid	Invalid	Invalid	Invalid	Invalid	Invalid	Invalid	CI bits

BLOCK DIAGRAM

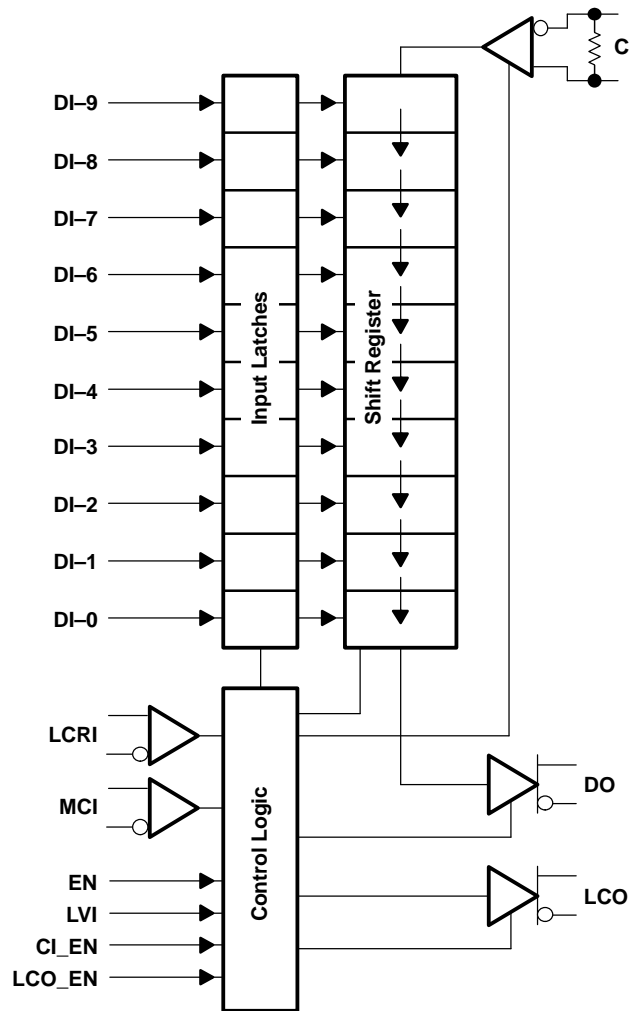

NOTE: The CI input includes a 110 Ω termination resistor.

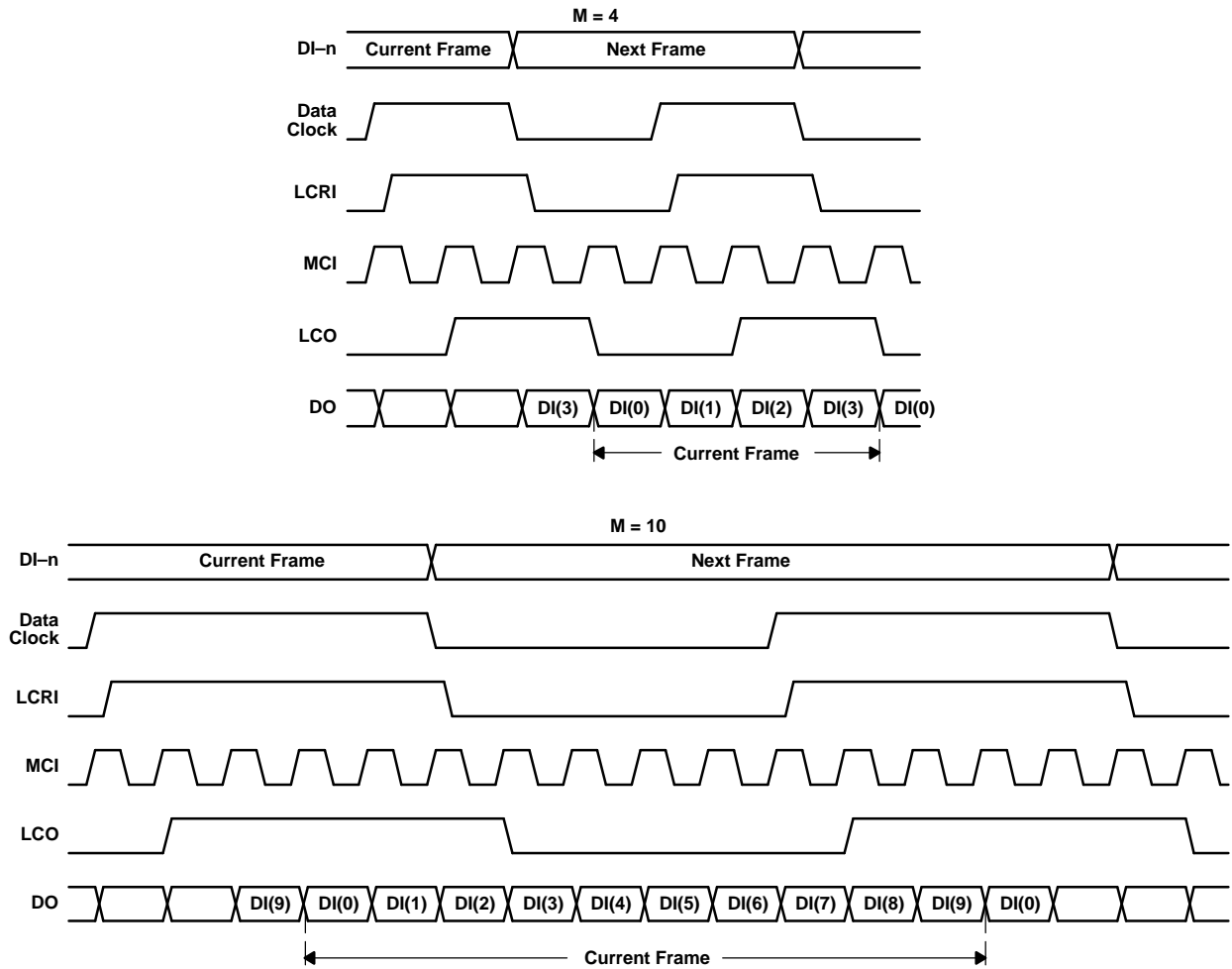
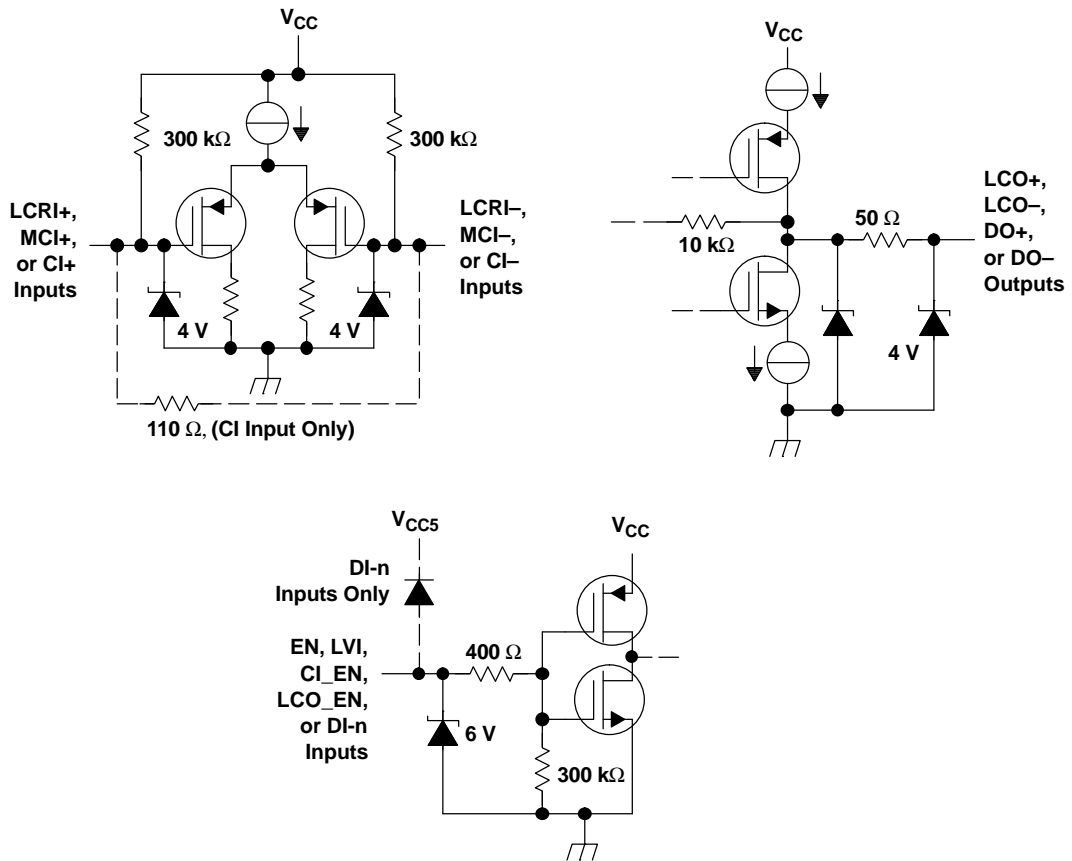

Figure 1. Operating Waveform Examples

EQUIVALENT INPUT AND OUTPUT SCHEMATIC DIAGRAMS



Terminal Functions

TERMINAL NAME	TERMINAL NO.	I/O	TYPE	DESCRIPTION
CI+, CI–	31, 32	I	LVDS	Cascade input. This may be used to connect additional SN65LVDS151 units when the multiplexing ratio M value is greater than 10. This input has an internal 110- Ω nominal termination resistor.
CI_EN	5	I	LVTTTL	Cascade input enable. Used to enable or disable the cascade input differential receiver. A high-level input enables the CI input, a low-level input disables the CI input.
DO–, DO+	17, 18	O	LVDS	Data output. This is the data being transmitted to the destination end of the serial link, or being supplied to another SN65LVDS151 unit in cascade.
EN	22	I	LVTTTL	Enable. Controls device operation. A high-level input enables the device; a low-level input disables and resets the device. When initially enabled, all outputs are in a low-level condition.
GND	2, 16, 19, 27		NA	Circuit ground
LCO+, LCO–	25, 24	O	LVDS	Link clock output This is the data block synchronization clock being transmitted to the destination end of the serial link.
LCO_EN	21	I	LVTTTL	Link clock output enable. Used to disable the link clock output when it is not being used. A high-level input enables the LCO output; a low-level input disables the LCO output.
LCRI+, LCR–	3, 4	I	LVDS	Link clock reference input. This is the clock for latching in the parallel data; it comes from the PLL frequency multiplier.
LVI	30	I	LVTTTL	Lock/valid input. This is a signal required for proper MuxIt system operation. It is directly connected to the LVO output of a SN65LVDS150. It is used to inhibit the operation of this device until after the PLL has stabilized. A low level input forces a reset of the internal latches and shift registers, and forces the DO and LCO outputs to a low level. A high level input enables operation.
MCI+, MC–	28, 29	I	LVDS	M-clock input. This is the high frequency multiplied clock input from the local PLL frequency multiplier. It synchronizes the transmission of the link data
DI-9–DI-0	6-15	I	LVTTTL	Parallel data inputs. Data is latched into the device on the first rising edge of MCI following a rising edge of LCRI.
V _{CC}	1, 23, 26		NA	Supply voltage
VCC5	20		NA	5-V V _{CC} tolerance bias. Tied to 5 V nominal when the LVTTTL inputs are being driven by a device powered from a 5-V supply, otherwise tied to local V _{CC}

ABSOLUTE MAXIMUM RATINGS

over operating free-air temperature range (unless otherwise noted)⁽¹⁾

	UNIT	
Supply voltage range, V _{CC} ⁽²⁾	–0.5 V to 4 V	
Voltage range	DI-0 through DI-9 inputs	–0.5 V to VCC5 +0.5 V
	EN, CI_EN, LCO_EN, LVI inputs, VCC5	–0.5 V to 5.5 V
	CI \pm , LCRI \pm , or MCI \pm Inputs, DO \pm , or LCO \pm outputs	–0.5 to 4 V
Electrostatic discharge, human body model ⁽³⁾	MCI \pm , LCRI \pm , CI \pm , DO \pm , LCO \pm , and GND	\pm 12 kV
	All pins	\pm 2 kV
Charged-device model ⁽⁴⁾	All pins	\pm 500 V
Continuous power dissipation	See Dissipation Rating Table	
Storage temperature range	–65°C to 150°C	
Lead temperature 1,6 mm (1/16 inch) from case for 10 seconds	260°C	

- (1) Stresses beyond those listed under *absolute maximum ratings* may cause permanent damage to the device. These are stress ratings only, and functional operation of the device at these or any other conditions beyond those indicated under *recommended operating conditions* is not implied. Exposure to absolute-maximum-rated conditions for extended periods may affect device reliability.
- (2) All voltage values, except differential I/O bus voltages, are with respect to network ground terminal.
- (3) Tested in accordance with JEDEC Standard 22, Test Method A114-B.
- (4) Tested in accordance with JEDEC Standard 22, Test Method C101.

DISSIPATION RATING TABLE

PACKAGE	$T_A \leq 25^\circ\text{C}$ POWER RATING	DERATING FACTOR ABOVE $T_A = 25^\circ\text{C}$	$T_A = 85^\circ\text{C}$ POWER RATING
DA	1453 mW	11.6 mW/°C	756 mW

RECOMMENDED OPERATING CONDITIONS

		MIN	NOM	MAX	UNIT
V_{CC}	Supply voltage	3	3.3	3.6	V
V_{IH}	High-level input voltage	2			V
V_{IL}	Low-level input voltage			0.8	V
$ V_{ID} $	Magnitude of differential input voltage	0.1		0.6	V
V_{IC}	Common-mode input voltage	LCRI, MCI, CI	$\frac{ V_{ID} }{2}$	$2.4 - \frac{ V_{ID} }{2}$	V
					$V_{CC} - 0.8$
T_A	Operating free-air temperature	40		85	°C

TIMING REQUIREMENTS

PARAMETERS		TEST CONDITIONS	MIN	MAX	UNIT
$t_{su(1)}$	LCRI \uparrow setup time before MCI \uparrow	See Figure 2	0.5		ns
$t_{h(1)}$	LCRI hold time after MCI \uparrow		0.3		ns
$t_{su(2)}$	Data setup time, DI-0–DI-9 before MCI \uparrow after LCRI \uparrow	See Figure 3	0		ns
$t_{h(2)}$	Data hold time, DI-0–DI-9 valid after MCI \uparrow after LCRI \uparrow		2		ns
$t_{su(3)}$	CI setup time before MCI \uparrow	$T_A \leq 25^\circ\text{C}$	0.8		ns
		$T_A = 85^\circ\text{C}$	1.1		
$t_{h(3)}$	CI hold time after MCI \uparrow		2.5		ns
t_c	Clock cycle time	LCRI	20	200	ns
		MCI	5	50	
t_w	High-level clock pulse width duration	MCI, LCRI	$0.4 t_c$	$0.6 t_c$	ns

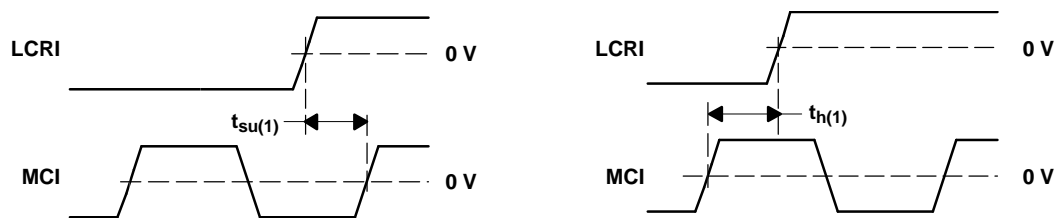

Figure 2. Clock Input Timing Requirements

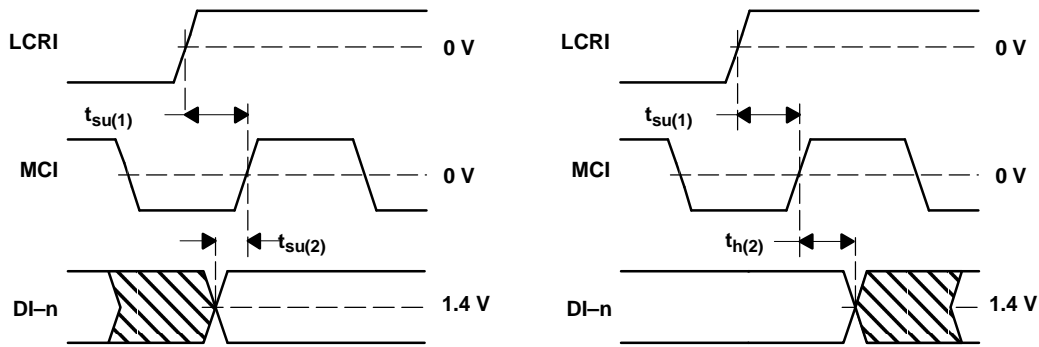

Figure 3. Data Input Timing Requirements

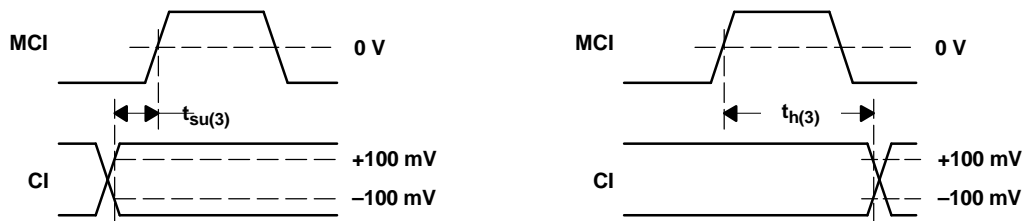

Figure 4. Cascade Input Timing Requirements

ELECTRICAL CHARACTERISTICS

over recommended operating conditions (unless otherwise noted)

PARAMETER		TEST CONDITIONS	MIN	TYP ⁽¹⁾	MAX	UNIT	
V_{ITH+}	Positive-going differential input voltage threshold	See Figure 5			100	mV	
V_{ITH-}	Negative-going differential input voltage threshold					mV	
$ V_{OD(SS)} $	Steady-state differential output voltage magnitude	$R_L = 100 \Omega$, $V_{ID} = \pm 100$ mV, See Figure 6 and Figure 7	247	340	454	mV	
$\Delta V_{OD(SS)} $	Change in steady-state differential output voltage magnitude between logic states		-50		50	mV	
$V_{OC(SS)}$	Steady-state common-mode output voltage	See Figure 8	1.125		1.375	V	
$\Delta V_{OC(SS)}$	Change in steady-state common-mode output voltage between logic states		-50		50	mV	
$V_{OC(PP)}$	Peak-to-peak change common-mode output voltage			50	150	mV	
I_{CC}	Supply current	Enabled, $R_L = 100 \Omega$		22	30	mA	
		Disabled		0.5	1		
		$f_{(MCI)} = 200$ MHz, $f_{(LCRI)} = 20$ MHz, $R_L = 100 \Omega$, DI-n= 1010101010		35	65		
I_{ID}	Differential input current	$(I_{I+} - I_{I-})$ (CI input)	$V_{ID} = 0.4$ V, $V_{IC} = 2.2$ V or 0.2 V		3	4.4	mA
		$(I_{I+} - I_{I-})$ (LCRI, MCI inputs)	$V_{IC} = 0.05$ V to 2.35 V, $V_{ID} = \pm 0.1$ V		-2	2	μ A
I_I	Input current	LCRI, MCI inputs	$V_I = 0$ V		-2	-20	μ A
			$V_I = 2.4$ V		-1.2		
		CI input	$V_I = 0$ V		-4	-40	μ A
			$V_I = 2.4$ V		-2.4		
$I_{I(OFF)}$	Power-off output current	LCRI, MCI inputs	$V_{CC} = 0$ V, $V_I = 3.6$ V			20	μ A
		CI input				40	
I_{IH}	High-level input current	EN, LVI, DI-n, LCO_EN	$V_{IH} = 2$ V			20	μ A
I_{IL}	Low-level input current	EN, LVI, DI-n, LCO_EN	$V_{IL} = 0.8$ V			10	μ A
I_{OS}	Short-circuit output current	DO, LCO	V_{O+} or $V_{O-} = 0$ V		-10	10	mA
			$V_{OD} = 0$ V		-10	10	

(1) All typical values are at $T_A = 25^\circ\text{C}$ and with $V_{CC} = 3.3$ V.

ELECTRICAL CHARACTERISTICS (continued)

over recommended operating conditions (unless otherwise noted)

PARAMETER		TEST CONDITIONS	MIN	TYP ⁽¹⁾	MAX	UNIT
I_{OZ}	High-impedance output current	$V_O = 0\text{ V or }V_{CC}$	-5		5	μA
$I_{O(OFF)}$	Power-off output current	$V_{CC} = 1.5\text{ V}, V_I = 3.6\text{ V}$	-5		5	μA
C_i	Input capacitance	LCRI, MCI inputs		3		pF

SWITCHING CHARACTERISTICS

over recommended operating conditions (unless otherwise noted)

PARAMETER		TEST CONDITIONS	MIN	TYP	MAX	UNIT	
$t_{d(1)}$	Propagation delay time, MCI \uparrow to DO \uparrow	$R_L = 100\ \Omega, C_L = 10\ \text{pF}$, See Figure 9	3	5	5.8	ns	
							$T_A \leq 25^\circ\text{C}$
$t_{d(2)}$	Propagation delay time, MCI \uparrow to DO \downarrow		$T_A = 85^\circ\text{C}$				
			$T_A \leq 25^\circ\text{C}$				
$t_{d(3)}$	Propagation delay time, MCI \uparrow to LCO \uparrow		$T_A = 85^\circ\text{C}$				
			$T_A \leq 25^\circ\text{C}$				
t_r	Differential output signal rise time	$R_L = 100\ \Omega, C_L = 10\ \text{pF}$, See Figure 10	0.3	0.8	1.5	ns	
t_f	Differential output signal fall time		0.3	0.8	1.5	ns	
$t_{sk(p)}$	Pulse skew ($ t_{PHL} - t_{PLH} $), DO		-250	0	250	ps	
$t_{sk(pp)}$	Part-to-part output skew, DO			0	2.3	ns	
$t_{sk(\omega)}$	Multiple-frequency skew, LCO \uparrow to DO \uparrow or DO \downarrow		See Figure 11	-250	0	250	ps
t_{PZL}	Propagation delay time, high-impedance to low-level		EN input to DO, LCO output, See Figure 12		3	20	ns
t_{PLZ}	Propagation delay time, low-level to high-impedance			3	10	ns	
t_{PHZ}	Propagation delay time, high-level to high-impedance			4	10	ns	

PARAMETER MEASUREMENT INFORMATION

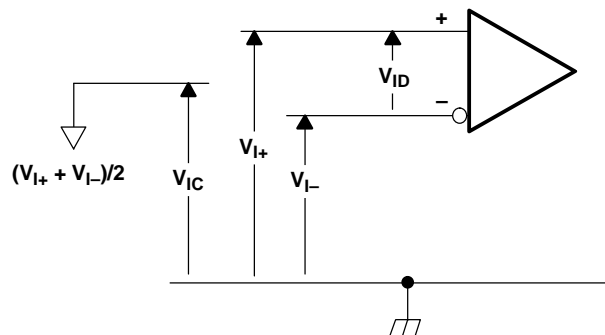

Figure 5. Receiver Voltage Definitions

Table 3. Receiver Minimum and Maximum Input Threshold Test Voltages

APPLIED VOLTAGES		RESULTING DIFFERENTIAL INPUT VOLTAGE	RESULTING COMMON-MODE INPUT VOLTAGE
V_{I+}	V_{I-}	V_{ID}	V_{IC}
1.25 V	1.15 V	100 mV	1.2 V
1.15 V	1.25 V	-100 mV	1.2 V
2.4 V	2.3 V	100 mV	2.35 V
2.3 V	2.4 V	-100 mV	2.35 V
0.1 V	0 V	100 mV	0.05 V
0 V	0.1 V	-100 mV	0.05 V
1.5 V	0.9 V	600 mV	1.2 V
0.9 V	1.5 V	-600 mV	1.2 V
2.4 V	1.8 V	600 mV	2.1 V
1.8 V	2.4 V	-600 mV	2.1 V
0.6 V	0 V	600 mV	0.3 V
0 V	0.6 V	-600 mV	0.3 V

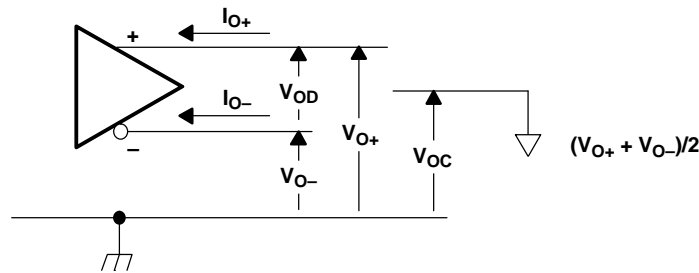

Figure 6. Driver Voltage and Current Definitions

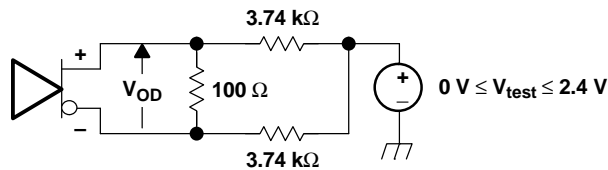
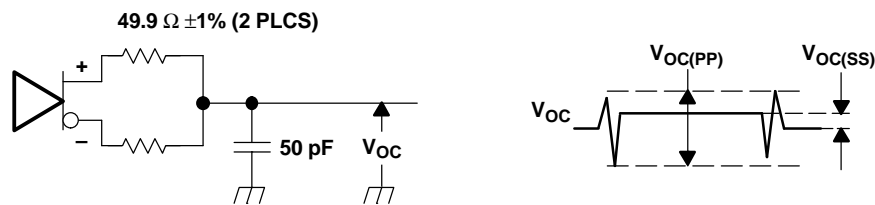

Figure 7. V_{OD} Test Circuit



- A. All input pulses are supplied by a generator having the following characteristics: t_r or $t_f \leq 1$ ns, pulse repetition rate (PRR) = 0.5 Mpps, Pulse width = 500 ± 10 ns. C_L includes instrumentation and fixture capacitance within 0.06 m of the D.U.T. The measurement of $V_{OC(PP)}$ is made on test equipment with a -3 dB bandwidth of at least 5 GHz.

Figure 8. Test Circuit and Definitions for the Driver Common-Mode Output Voltage

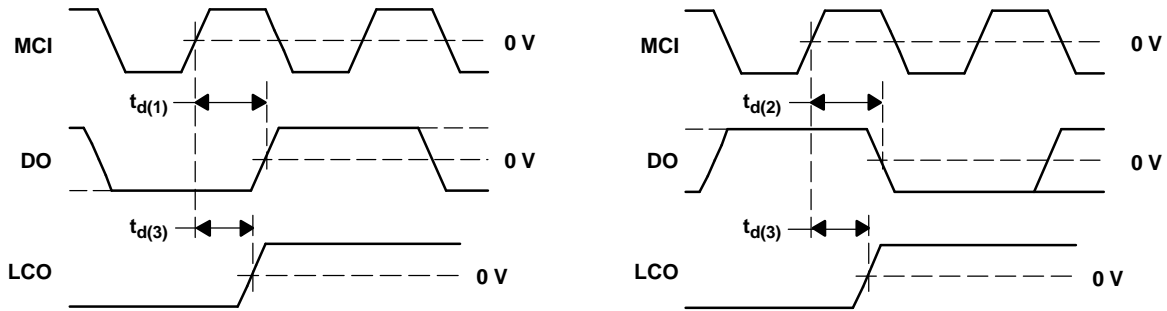
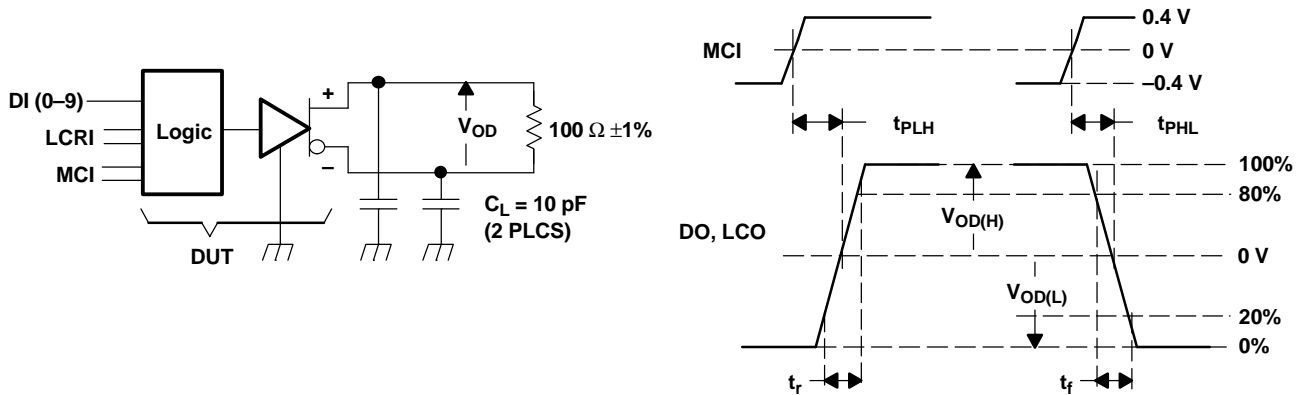

Figure 9. Output Timing Waveforms



- A. All input pulses are supplied by generators having the following characteristics: t_r or $t_f \leq 1$ ns, MCI pulse repetition rate (PRR) = 50 Mpps, MCI Pulse width = 10 ± 0.2 ns, LCRI pulse repetition rate (PRR) = 5 Mpps, LCRI pulse width = 100 ± 20 ns. C_L includes instrumentation and fixture capacitance within 0,06 m of the D.U.T.

Figure 10. Test Circuit, Timing, and Voltage Definitions for the Differential Output Signal

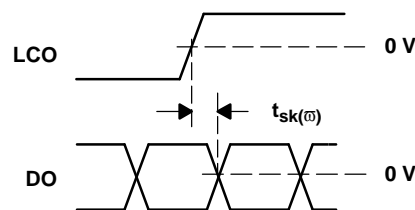

Figure 11. LCO to DO Multiple-Frequency Skew Waveforms

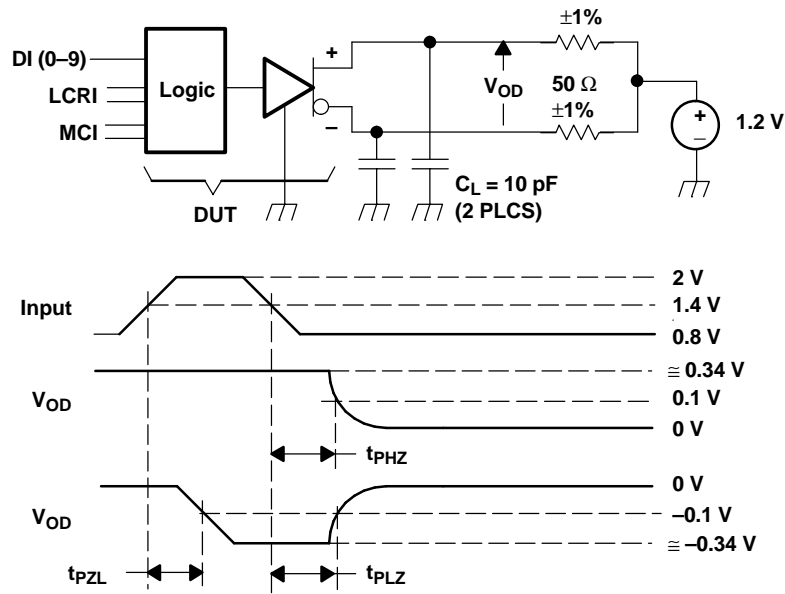

Figure 12. Enable/Disable Time Waveforms

TYPICAL CHARACTERISTICS
AVERAGE SUPPLY CURRENT
VS
FREQUENCY

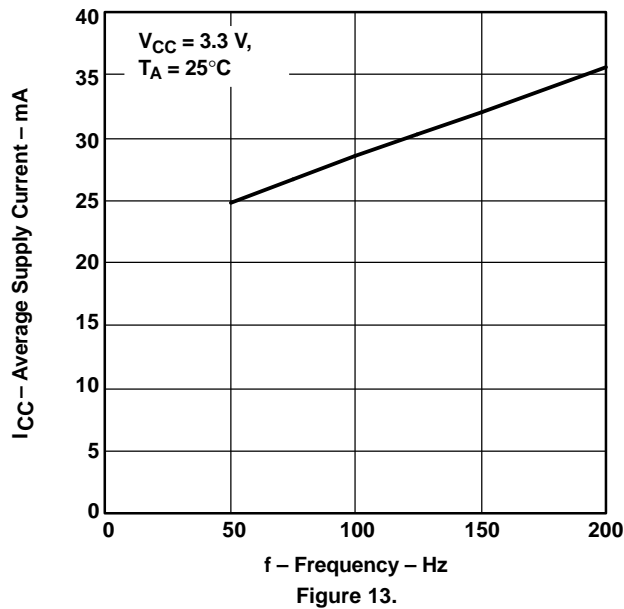

Figure 13.

IMPORTANT NOTICE

Texas Instruments Incorporated and its subsidiaries (TI) reserve the right to make corrections, modifications, enhancements, improvements, and other changes to its products and services at any time and to discontinue any product or service without notice. Customers should obtain the latest relevant information before placing orders and should verify that such information is current and complete. All products are sold subject to TI's terms and conditions of sale supplied at the time of order acknowledgment.

TI warrants performance of its hardware products to the specifications applicable at the time of sale in accordance with TI's standard warranty. Testing and other quality control techniques are used to the extent TI deems necessary to support this warranty. Except where mandated by government requirements, testing of all parameters of each product is not necessarily performed.

TI assumes no liability for applications assistance or customer product design. Customers are responsible for their products and applications using TI components. To minimize the risks associated with customer products and applications, customers should provide adequate design and operating safeguards.

TI does not warrant or represent that any license, either express or implied, is granted under any TI patent right, copyright, mask work right, or other TI intellectual property right relating to any combination, machine, or process in which TI products or services are used. Information published by TI regarding third-party products or services does not constitute a license from TI to use such products or services or a warranty or endorsement thereof. Use of such information may require a license from a third party under the patents or other intellectual property of the third party, or a license from TI under the patents or other intellectual property of TI.

Reproduction of TI information in TI data books or data sheets is permissible only if reproduction is without alteration and is accompanied by all associated warranties, conditions, limitations, and notices. Reproduction of this information with alteration is an unfair and deceptive business practice. TI is not responsible or liable for such altered documentation. Information of third parties may be subject to additional restrictions.

Resale of TI products or services with statements different from or beyond the parameters stated by TI for that product or service voids all express and any implied warranties for the associated TI product or service and is an unfair and deceptive business practice. TI is not responsible or liable for any such statements.

TI products are not authorized for use in safety-critical applications (such as life support) where a failure of the TI product would reasonably be expected to cause severe personal injury or death, unless officers of the parties have executed an agreement specifically governing such use. Buyers represent that they have all necessary expertise in the safety and regulatory ramifications of their applications, and acknowledge and agree that they are solely responsible for all legal, regulatory and safety-related requirements concerning their products and any use of TI products in such safety-critical applications, notwithstanding any applications-related information or support that may be provided by TI. Further, Buyers must fully indemnify TI and its representatives against any damages arising out of the use of TI products in such safety-critical applications.

TI products are neither designed nor intended for use in military/aerospace applications or environments unless the TI products are specifically designated by TI as military-grade or "enhanced plastic." Only products designated by TI as military-grade meet military specifications. Buyers acknowledge and agree that any such use of TI products which TI has not designated as military-grade is solely at the Buyer's risk, and that they are solely responsible for compliance with all legal and regulatory requirements in connection with such use.

TI products are neither designed nor intended for use in automotive applications or environments unless the specific TI products are designated by TI as compliant with ISO/TS 16949 requirements. Buyers acknowledge and agree that, if they use any non-designated products in automotive applications, TI will not be responsible for any failure to meet such requirements.

Following are URLs where you can obtain information on other Texas Instruments products and application solutions:

Products

Amplifiers	amplifier.ti.com
Data Converters	dataconverter.ti.com
DSP	dsp.ti.com
Clocks and Timers	www.ti.com/clocks
Interface	interface.ti.com
Logic	logic.ti.com
Power Mgmt	power.ti.com
Microcontrollers	microcontroller.ti.com
RFID	www.ti-rfid.com
RF/IF and ZigBee® Solutions	www.ti.com/lprf

Applications

Audio	www.ti.com/audio
Automotive	www.ti.com/automotive
Broadband	www.ti.com/broadband
Digital Control	www.ti.com/digitalcontrol
Medical	www.ti.com/medical
Military	www.ti.com/military
Optical Networking	www.ti.com/opticalnetwork
Security	www.ti.com/security
Telephony	www.ti.com/telephony
Video & Imaging	www.ti.com/video
Wireless	www.ti.com/wireless

Mailing Address: Texas Instruments, Post Office Box 655303, Dallas, Texas 75265
Copyright © 2008, Texas Instruments Incorporated