

# SN74SSTU32866A

## 25-BIT CONFIGURABLE REGISTERED BUFFER WITH ADDRESS-PARITY TEST

SCAS803A – JUNE 2005 – REVISED NOVEMBER 2007

- Member of the Texas Instruments Widebus+™ Family
- Pinout Optimizes DDR2 DIMM PCB Layout
- Configurable as 25-Bit 1:1 or 14-Bit 1:2 Registered Buffer
- Chip-Select Inputs Gate the Data Outputs from Changing State and Minimizes System Power Consumption
- Output Edge-Control Circuitry Minimizes Switching Noise in an Unterminated Line
- Supports SSTL\_18 Data Inputs
- Differential Clock (CLK and  $\overline{\text{CLK}}$ ) Inputs
- Supports LVCMOS Switching Levels on the Control and  $\overline{\text{RESET}}$  Inputs
- Checks Parity on DIMM-Independent Data Inputs
- Able to Cascade with a Second SN74SSTU32866A
- $\overline{\text{RESET}}$  Input Disables Differential Input Receivers, Resets All Registers, and Forces All Outputs Low, Except  $\overline{\text{QERR}}$
- Latch-Up Performance Exceeds 100 mA Per JESD 78, Class II
- ESD Protection Exceeds JESD 22
  - 2000-V Human-Body Model (A114-A)
  - 200-V Machine Model (A115-A)
  - 1000-V Charged-Device Model (C101)

### description/ordering information

This 25-bit 1:1 or 14-bit 1:2 configurable registered buffer is designed for 1.7-V to 1.9-V  $V_{CC}$  operation. In the 1:1 pinout configuration, only 1 device per DIMM is required to drive 9 SDRAM loads. In the 1:2 pinout configuration, 2 devices per DIMM are required to drive 18 SDRAM loads.

All inputs are SSTL\_18, except the reset ( $\overline{\text{RESET}}$ ) and control (Cn) inputs which are LVCMOS. All outputs are edge-controlled circuits optimized for unterminated DIMM loads and meet SSTL\_18 specifications, except the open-drain error ( $\overline{\text{QERR}}$ ) output.

The SN74SSTU32866A buffer operates from a differential clock (CLK and  $\overline{\text{CLK}}$ ). Data are registered at the crossing of CLK going high and  $\overline{\text{CLK}}$  going low.

The SN74SSTU32866A buffer accepts a parity bit from the memory controller on the parity bit (PAR\_IN) input, compares it with the data received on the DIMM-independent D-inputs (D2–D3, D5–D6, D8–D25 when C0 = 0 and C1 = 0; D2–D3, D5–D6, D8–D14 when C0 = 0 and C1=1; or D1–D6, D8–D13 when C0 = 1 and C1 = 1) and indicates whether a parity error has occurred on the open-drain  $\overline{\text{QERR}}$  pin (active low). The convention is even parity; i.e., valid parity is defined as an even number of ones across the DIMM-independent data inputs, combined with the parity input bit. To calculate parity, all DIMM-independent data inputs must be tied to a known logic state.

When used as a single device, the C0 and C1 inputs are tied low. In this configuration, parity is checked on the PAR\_IN input signal, which arrives one cycle after the input data to which it applies. Two clock cycles after the data are registered, the corresponding partial-parity-out (PPO) and  $\overline{\text{QERR}}$  signals are generated.

### ORDERING INFORMATION

T <sub>A</sub>	PACKAGE†	ORDERABLE PART NUMBER	TOP-SIDE MARKING
0°C to 70°C	LFBGA – ZKE    Tape and reel	SN74SSTU32866AZKER	SU866A

† Package drawings, standard packing quantities, thermal data, symbolization, and PCB design guidelines are available at [www.ti.com/sc/package](http://www.ti.com/sc/package).



Please be aware that an important notice concerning availability, standard warranty, and use in critical applications of Texas Instruments semiconductor products and disclaimers thereto appears at the end of this data sheet.

Widebus+ is a trademark of Texas Instruments.

PRODUCTION DATA information is current as of publication date. Products conform to specifications per the terms of Texas Instruments standard warranty. Production processing does not necessarily include testing of all parameters.



POST OFFICE BOX 655303 • DALLAS, TEXAS 75265

Copyright © 2005, Texas Instruments Incorporated

# SN74SSTU32866A

## 25-BIT CONFIGURABLE REGISTERED BUFFER WITH ADDRESS-PARITY TEST

SCAS803A – JUNE 2005 – REVISED NOVEMBER 2007

---

### description/ordering information (continued)

When used in pairs, the C0 input of the first register is tied low, and the C0 input of the second register is tied high. The C1 input of both registers is tied high. Parity, which arrives one cycle after the data input to which it applies, is checked on the PAR\_IN input signal of the first device. Two clock cycles after the data are registered, the corresponding PPO and  $\overline{QERR}$  signals are generated on the second device. The PPO output of the first register is cascaded to the PAR\_IN of the second SN74SSTU32866A. The  $\overline{QERR}$  output of the first SN74SSTU32866A is left floating, and the valid error information is latched on the  $\overline{QERR}$  output of the second SN74SSTU32866A.

If an error occurs and the  $\overline{QERR}$  output is driven low, then it stays latched low for a minimum of two clock cycles or until  $\overline{RESET}$  is driven low. If two or more consecutive parity errors occur, then the  $\overline{QERR}$  output is driven low and latched low for a clock duration equal to the parity-error duration or until  $\overline{RESET}$  is driven low. The DIMM-dependent signals ( $\overline{DCKE}$ ,  $\overline{DCS}$ ,  $\overline{DODT}$ , and  $\overline{CSR}$ ) are not included in the parity-check computation.

The C0 input controls the pinout configuration of the 1:2 pinout from register-A configuration (when low) to register-B configuration (when high). The C1 input controls the pinout configuration from 25-bit 1:1 (when low) to 14-bit 1:2 (when high). C0 and C1 must not be switched during normal operation. They must be hard-wired to a valid low or high level to configure the register in the desired mode. In the 25-bit 1:1 pinout configuration, the A6, D6, and H6 terminals are driven low and are do-not-use (DNU) pins.

In the DDR2 RDIMM application,  $\overline{RESET}$  is specified to be completely asynchronous with respect to CLK and  $\overline{CLK}$ . Therefore, no timing relationship can be ensured between the two. When entering reset, the register is cleared, and the data outputs are driven low quickly, relative to the time required to disable the differential input receivers. However, when coming out of reset, the register becomes active quickly, relative to the time required to enable the differential input receivers. As long as the data inputs are low, and the clock is stable during the time from the low-to-high transition of  $\overline{RESET}$  until the input receivers are fully enabled, the design of the SN74SSTU32866A ensures that the outputs remain low, thus ensuring there will be no glitches on the output.

To ensure defined outputs from the register before a stable clock has been supplied,  $\overline{RESET}$  must be held in the low state during power up.

The device supports low-power standby operation. When  $\overline{RESET}$  is low, the differential input receivers are disabled, and undriven (floating) data, clock, and reference voltage ( $V_{REF}$ ) inputs are allowed. In addition, when  $\overline{RESET}$  is low, all registers are reset and all outputs are forced low, except  $\overline{QERR}$ . The LVCMOS  $\overline{RESET}$  and Cn inputs always must be held at a valid logic high or low level.

The device also supports low-power active operation by monitoring both system chip select ( $\overline{DCS}$  and  $\overline{CSR}$ ) inputs and gates the Qn and PPO outputs from changing states when both  $\overline{DCS}$  and  $\overline{CSR}$  inputs are high. If either  $\overline{DCS}$  or  $\overline{CSR}$  input is low, then the Qn and PPO outputs function normally. Also, if the internal low-power signal ( $\overline{LPS1}$ ) is high (one cycle after  $\overline{DCS}$  and  $\overline{CSR}$  go high), then the device gates the  $\overline{QERR}$  output from changing states. If  $\overline{LPS1}$  is low, then the  $\overline{QERR}$  output functions normally. The  $\overline{RESET}$  input has priority over the  $\overline{DCS}$  and  $\overline{CSR}$  control and, when driven low, forces the Qn and PPO outputs low and forces the  $\overline{QERR}$  output high. If the  $\overline{DCS}$  control functionality is not desired, then the  $\overline{CSR}$  input can be hard-wired to ground, in which case the setup-time requirement for  $\overline{DCS}$  is the same as for the other D data inputs. To control the low-power mode with  $\overline{DCS}$  only, the  $\overline{CSR}$  input must be pulled up to  $V_{CC}$  through a pullup resistor.

The two  $V_{REF}$  pins (A3 and T3) are connected together internally by approximately 150  $\Omega$ . However, it is necessary to connect only one of the two  $V_{REF}$  pins to the external  $V_{REF}$  power supply. An unused  $V_{REF}$  pin must be terminated with a  $V_{REF}$  coupling capacitor.

# SN74SSTU32866A

## 25-BIT CONFIGURABLE REGISTERED BUFFER WITH ADDRESS-PARITY TEST

SCAS803A – JUNE 2005 – REVISED NOVEMBER 2007

**ZKE PACKAGE  
(TOP VIEW)**

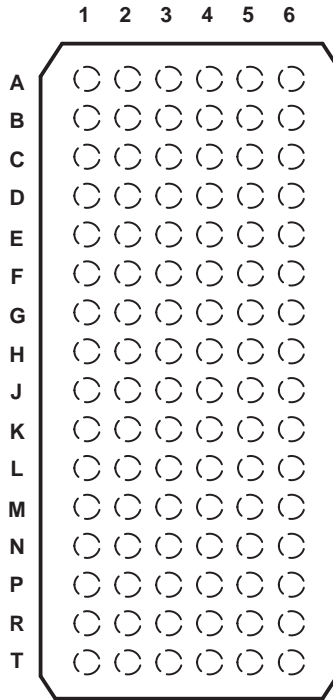

**terminal assignments for 1:1 register (C0 = 0, C1 = 0)**

	1	2	3	4	5	6
A	D1 (DCKE)	PPO	V <sub>REF</sub>	V <sub>CC</sub>	Q1 (QCKE)	DNU
B	D2	D15	GND	GND	Q2	Q15
C	D3	D16	V <sub>CC</sub>	V <sub>CC</sub>	Q3	Q16
D	D4 (DODT)	$\overline{QERR}$	GND	GND	Q4 (QODT)	DNU
E	D5	D17	V <sub>CC</sub>	V <sub>CC</sub>	Q5	Q17
F	D6	D18	GND	GND	Q6	Q18
G	PAR_IN	$\overline{RESET}$	V <sub>CC</sub>	V <sub>CC</sub>	C1	C0
H	CLK	D7 ( $\overline{DCS}$ )	GND	GND	Q7 ( $\overline{QCS}$ )	DNU
J	$\overline{CLK}$	$\overline{CSR}$	V <sub>CC</sub>	V <sub>CC</sub>	NC	NC
K	D8	D19	GND	GND	Q8	Q19
L	D9	D20	V <sub>CC</sub>	V <sub>CC</sub>	Q9	Q20
M	D10	D21	GND	GND	Q10	Q21
N	D11	D22	V <sub>CC</sub>	V <sub>CC</sub>	Q11	Q22
P	D12	D23	GND	GND	Q12	Q23
R	D13	D24	V <sub>CC</sub>	V <sub>CC</sub>	Q13	Q24
T	D14	D25	V <sub>REF</sub>	V <sub>CC</sub>	Q14	Q25

Each pin name in parentheses indicates the DDR2 DIMM signal name.

DNU – Do not use

NC – No internal connection

# SN74SSTU32866A

## 25-BIT CONFIGURABLE REGISTERED BUFFER

### WITH ADDRESS-PARITY TEST

SCAS803A – JUNE 2005 – REVISED NOVEMBER 2007

logic diagram for 1:1 register configuration (positive logic); C0 = 0, C1 = 0

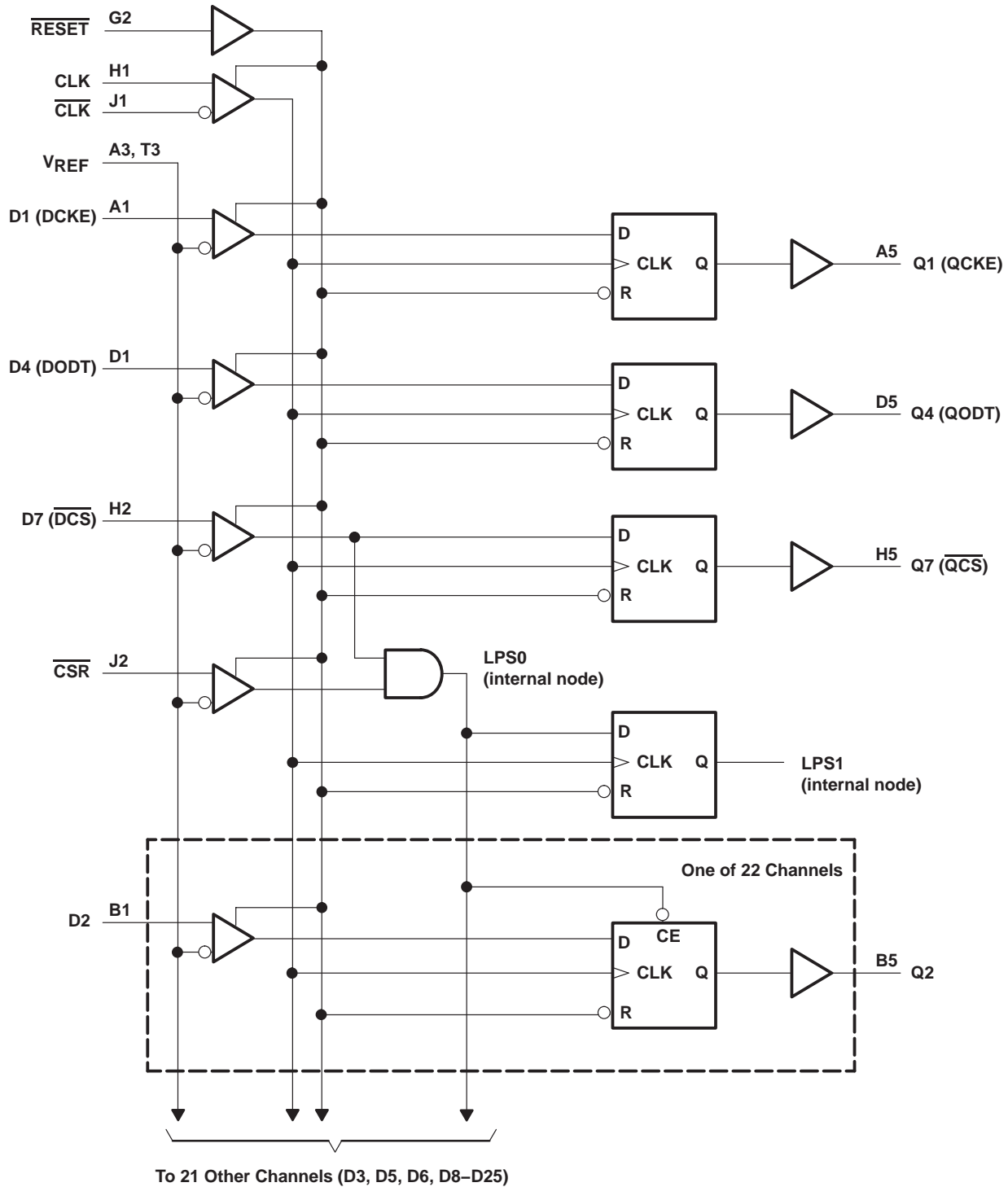

# SN74SSTU32866A 25-BIT CONFIGURABLE REGISTERED BUFFER WITH ADDRESS-PARITY TEST

SCAS803A – JUNE 2005 – REVISED NOVEMBER 2007

parity logic diagram for 1:1 register configuration (positive logic); C0 = 0, C1 = 0

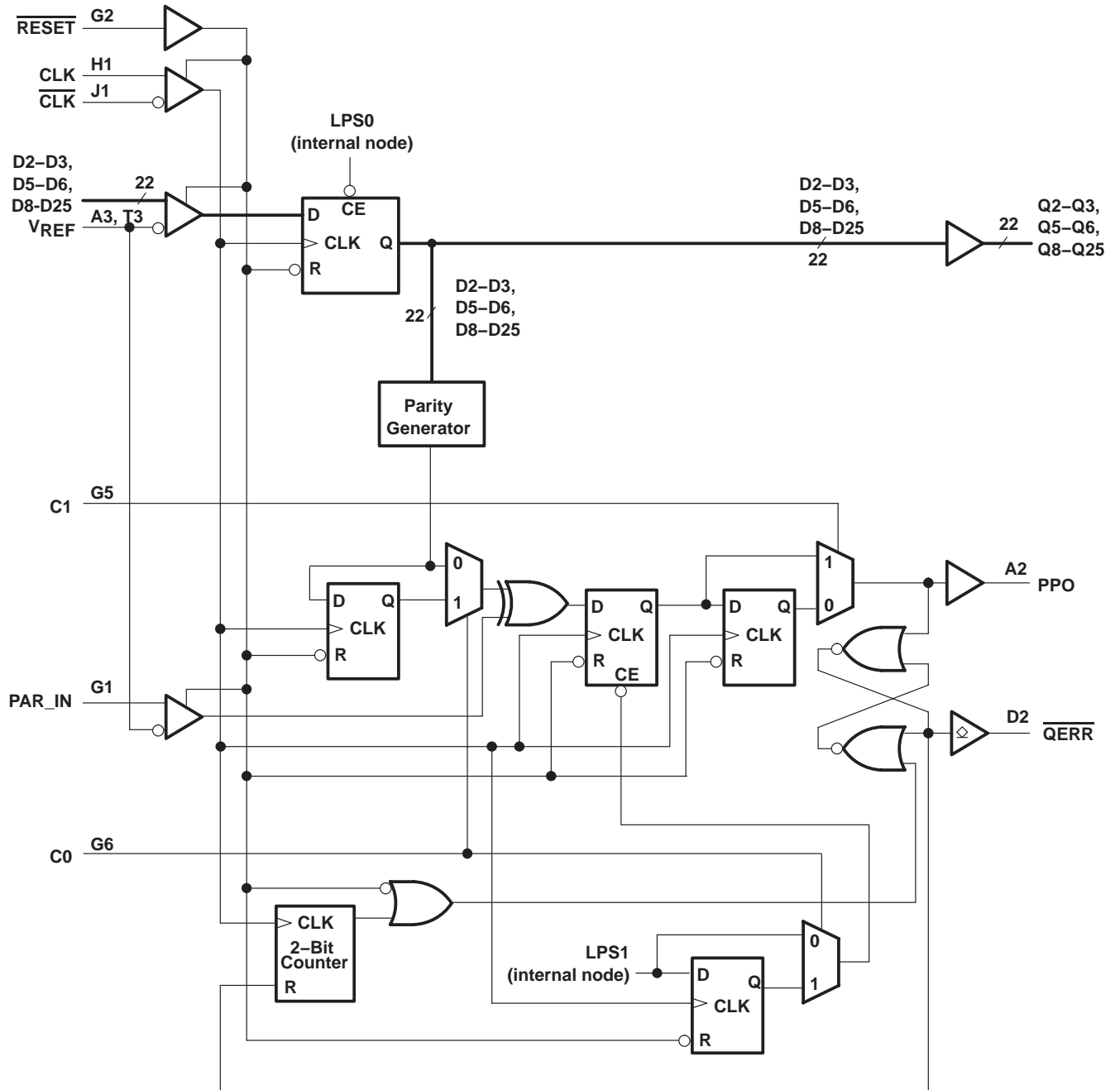

# SN74SSTU32866A

## 25-BIT CONFIGURABLE REGISTERED BUFFER WITH ADDRESS-PARITY TEST

SCAS803A – JUNE 2005 – REVISED NOVEMBER 2007

### ZKE PACKAGE (TOP VIEW)

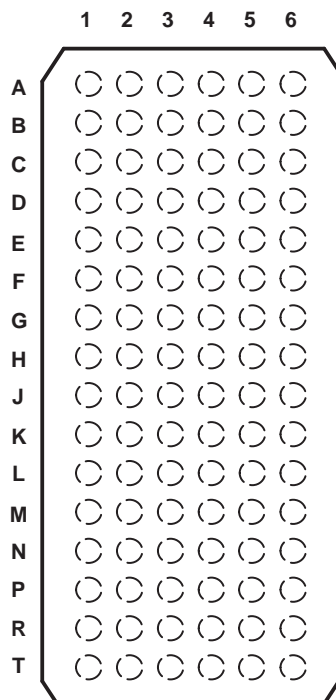

### terminal assignments for 1:2 register-A (C0 = 0, C1 = 1)

	1	2	3	4	5	6
A	D1 (DCKE)	PPO	VREF	VCC	Q1A (QCKEA)	Q1B (QCKEB)
B	D2	DNU	GND	GND	Q2A	Q2B
C	D3	DNU	VCC	VCC	Q3A	Q3B
D	D4 (DODT)	$\overline{QERR}$	GND	GND	Q4A (QODTA)	Q4B (QODTB)
E	D5	DNU	VCC	VCC	Q5A	Q5B
F	D6	DNU	GND	GND	Q6A	Q6B
G	PAR_IN	$\overline{RESET}$	VCC	VCC	C1	C0
H	CLK	D7 ( $\overline{DCS}$ )	GND	GND	Q7A (QCSA)	Q7B (QCSB)
J	$\overline{CLK}$	$\overline{CSR}$	VCC	VCC	NC	NC
K	D8	DNU	GND	GND	Q8A	Q8B
L	D9	DNU	VCC	VCC	Q9A	Q9B
M	D10	DNU	GND	GND	Q10A	Q10B
N	D11	DNU	VCC	VCC	Q11A	Q11B
P	D12	DNU	GND	GND	Q12A	Q12B
R	D13	DNU	VCC	VCC	Q13A	Q13B
T	D14	DNU	VREF	VCC	Q14A	Q14B

Each pin name in parentheses indicates the DDR2 DIMM signal name.

DNU – Do not use

NC – No internal connection

# SN74SSTU32866A

## 25-BIT CONFIGURABLE REGISTERED BUFFER WITH ADDRESS-PARITY TEST

SCAS803A – JUNE 2005 – REVISED NOVEMBER 2007

logic diagram for 1:2 register-A configuration (positive logic); C0 = 0, C1 = 1

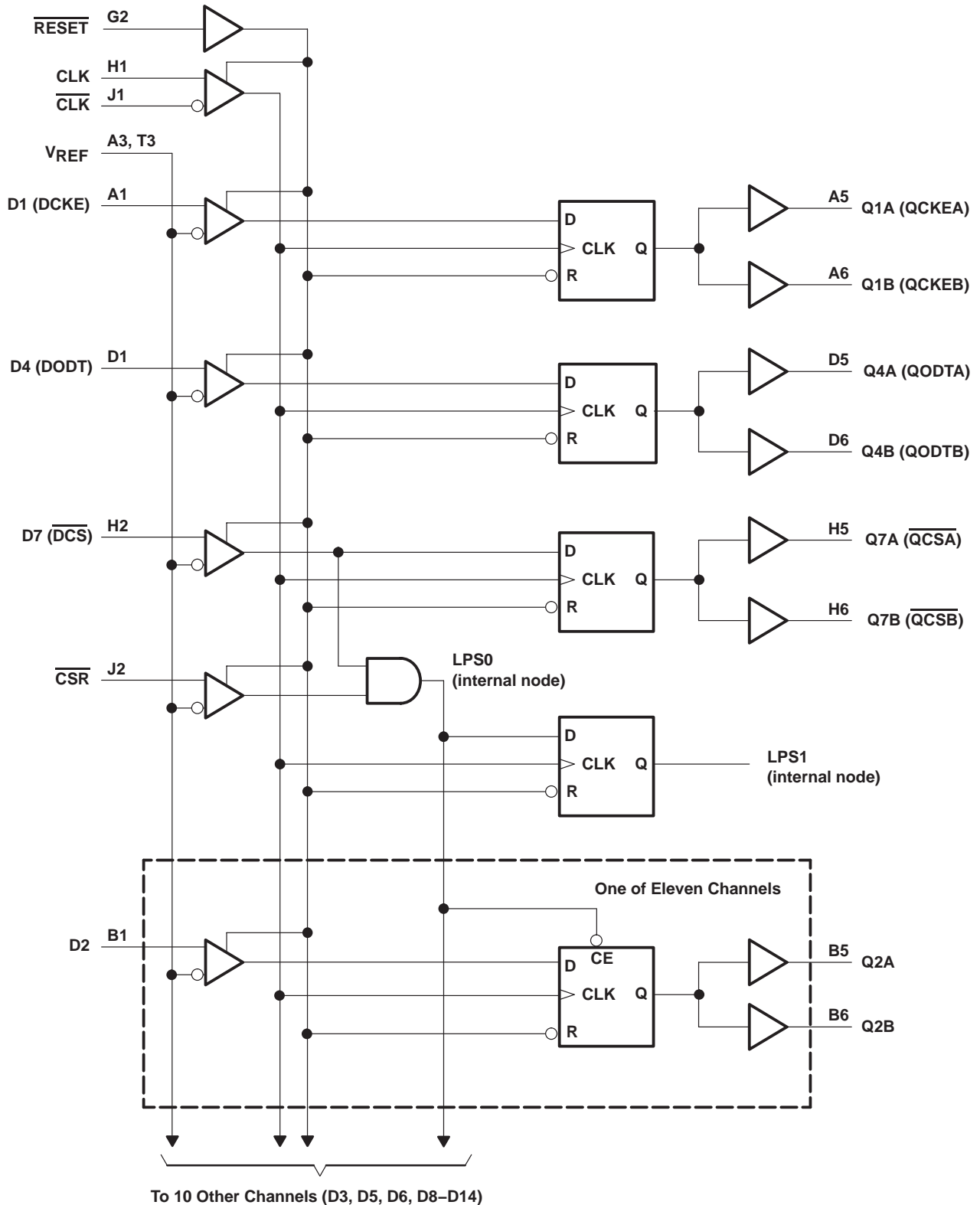

# SN74SSTU32866A

## 25-BIT CONFIGURABLE REGISTERED BUFFER

### WITH ADDRESS-PARITY TEST

SCAS803A – JUNE 2005 – REVISED NOVEMBER 2007

parity logic diagram for 1:2 register-A configuration (positive logic); C0 = 0, C1 = 1

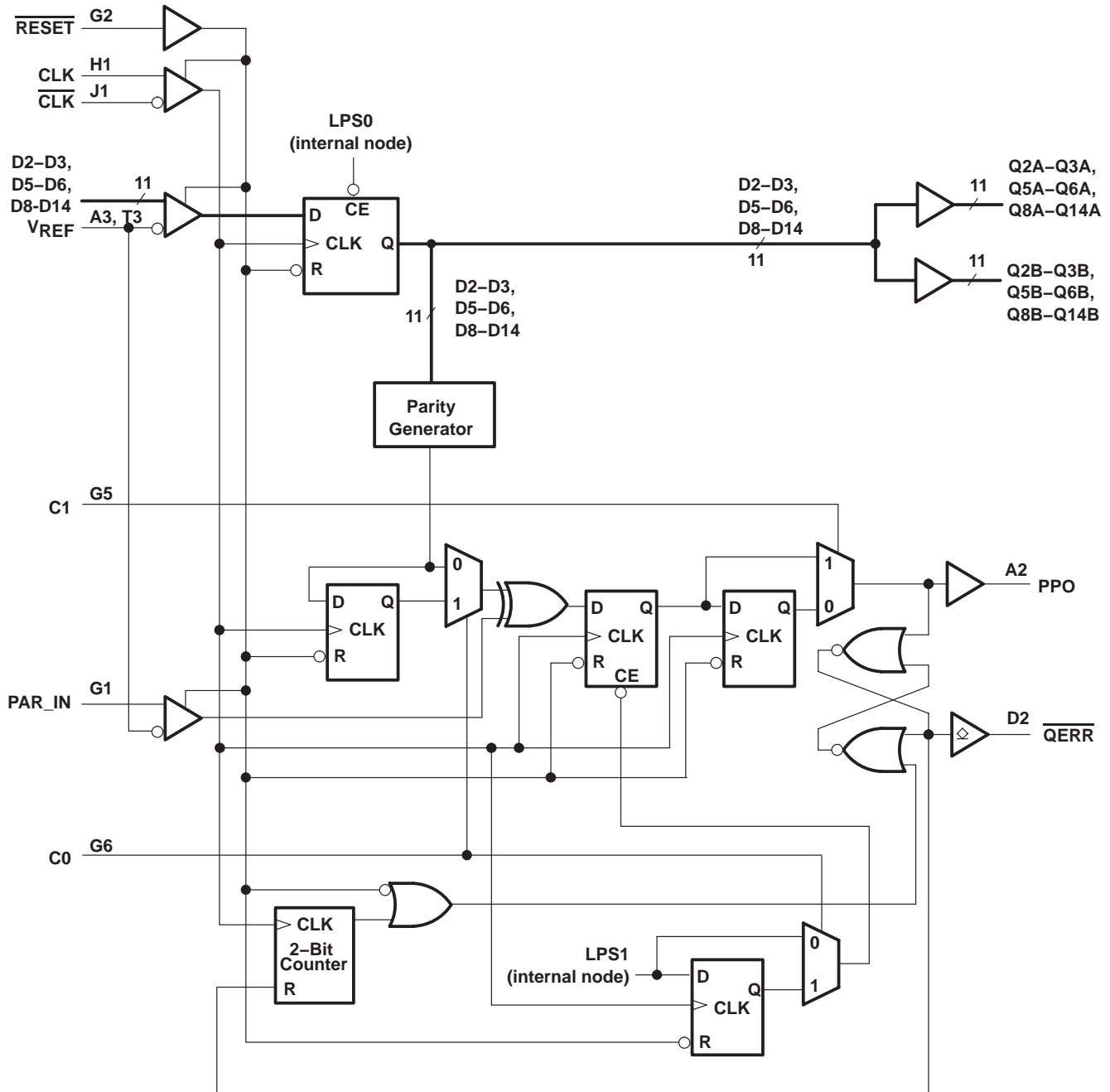



**SN74SSTU32866A**  
**25-BIT CONFIGURABLE REGISTERED BUFFER**  
**WITH ADDRESS-PARITY TEST**

SCAS803A – JUNE 2005 – REVISED NOVEMBER 2007

**ZKE PACKAGE**  
**(TOP VIEW)**

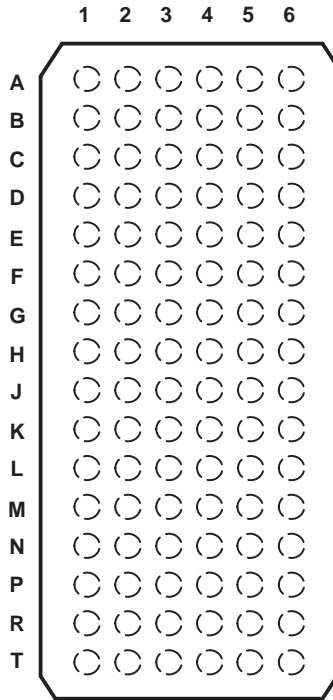

**terminal assignments for 1:2 register-B (C0 = 1, C1 = 1)**

	1	2	3	4	5	6
A	D1	PPO	V <sub>REF</sub>	V <sub>CC</sub>	Q1A	Q1B
B	D2	DNU	GND	GND	Q2A	Q2B
C	D3	DNU	V <sub>CC</sub>	V <sub>CC</sub>	Q3A	Q3B
D	D4	$\overline{QERR}$	GND	GND	Q4A	Q4B
E	D5	DNU	V <sub>CC</sub>	V <sub>CC</sub>	Q5A	Q5B
F	D6	DNU	GND	GND	Q6A	Q6B
G	PAR_IN	$\overline{RESET}$	V <sub>CC</sub>	V <sub>CC</sub>	C1	C0
H	CLK	D7 ( $\overline{DCS}$ )	GND	GND	$\overline{Q7A}$ (QCSA)	$\overline{Q7B}$ (QCSB)
J	$\overline{CLK}$	$\overline{CSR}$	V <sub>CC</sub>	V <sub>CC</sub>	NC	NC
K	D8	DNU	GND	GND	Q8A	Q8B
L	D9	DNU	V <sub>CC</sub>	V <sub>CC</sub>	Q9A	Q9B
M	D10	DNU	GND	GND	Q10A	Q10B
N	D11 (DODT)	DNU	V <sub>CC</sub>	V <sub>CC</sub>	Q11A (QODTA)	Q11B (QODTB)
P	D12	DNU	GND	GND	Q12A	Q12B
R	D13	DNU	V <sub>CC</sub>	V <sub>CC</sub>	Q13A	Q13B
T	D14 (DCKE)	DNU	V <sub>REF</sub>	V <sub>CC</sub>	Q14A (QCKEA)	Q14B (QCKEB)

Each pin name in parentheses indicates the DDR2 DIMM signal name.

DNU – Do not use

NC – No internal connection

# SN74SSTU32866A

## 25-BIT CONFIGURABLE REGISTERED BUFFER

### WITH ADDRESS-PARITY TEST

SCAS803A – JUNE 2005 – REVISED NOVEMBER 2007

logic diagram for 1:2 register-B configuration (positive logic); C0 = 1, C1 = 1

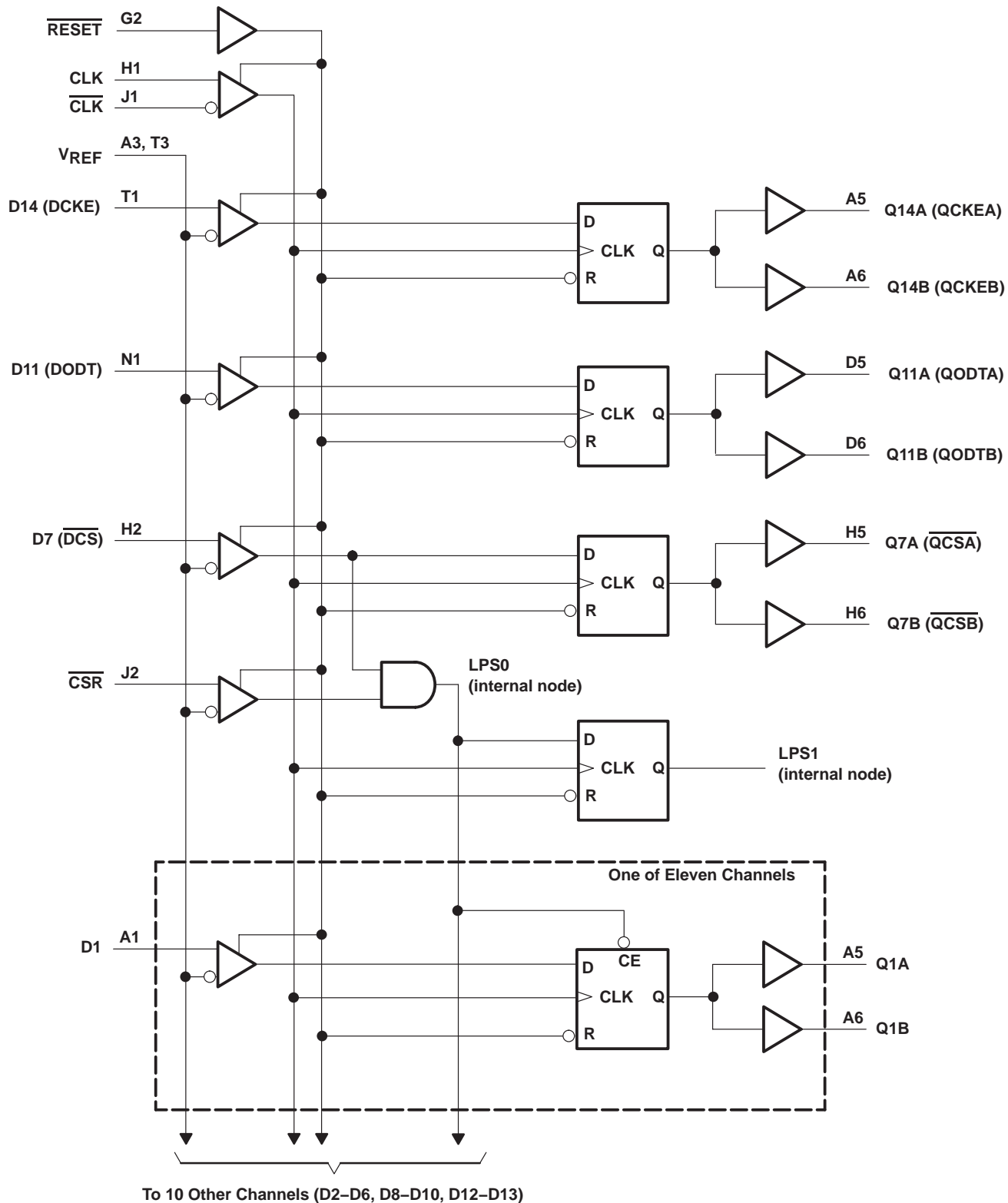

# SN74SSTU32866A

## 25-BIT CONFIGURABLE REGISTERED BUFFER WITH ADDRESS-PARITY TEST

SCAS803A – JUNE 2005 – REVISED NOVEMBER 2007

parity logic diagram for 1:2 register-B configuration (positive logic); C0 = 1, C1 = 1

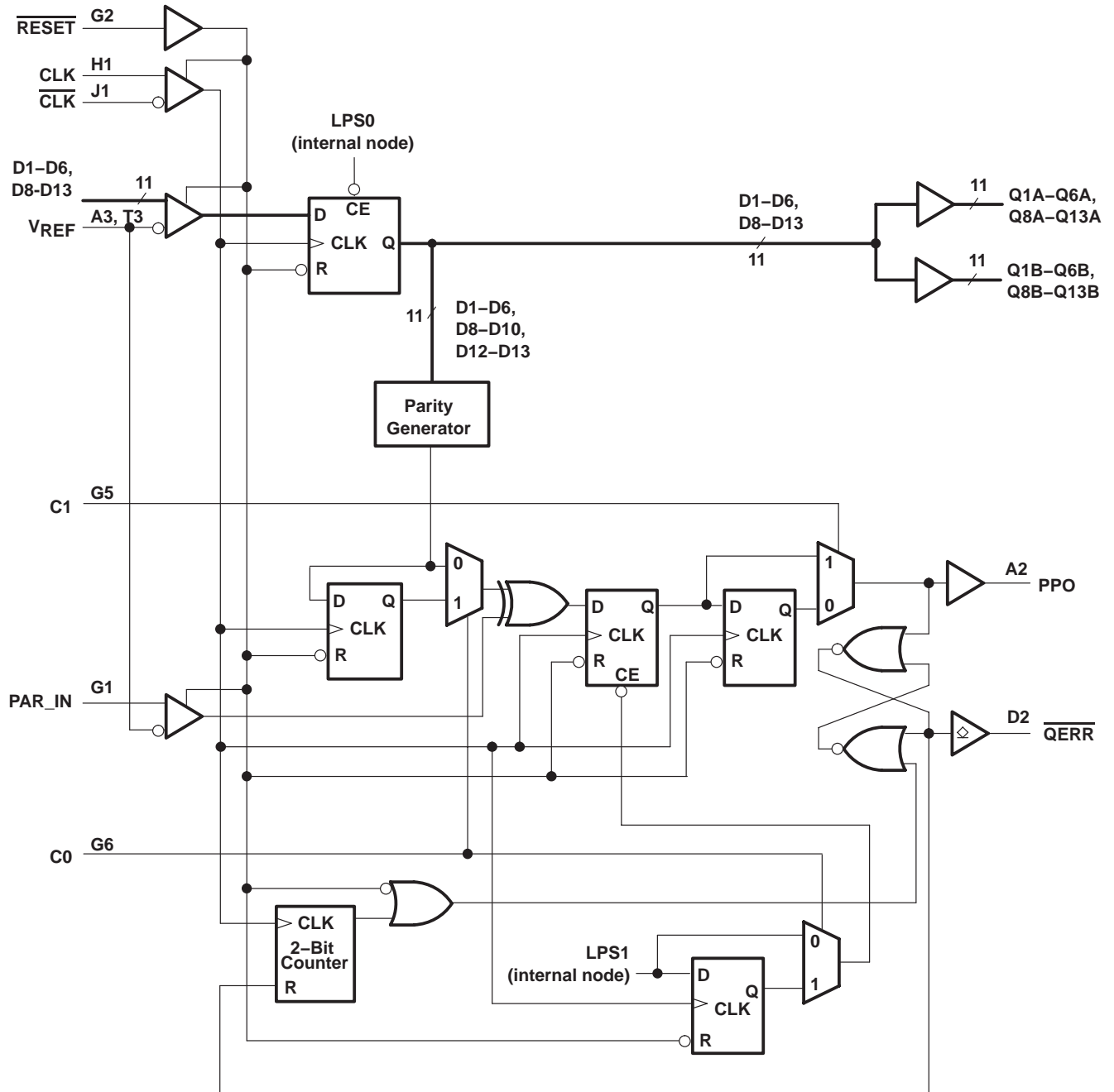

# SN74SSTU32866A

## 25-BIT CONFIGURABLE REGISTERED BUFFER WITH ADDRESS-PARITY TEST

SCAS803A – JUNE 2005 – REVISED NOVEMBER 2007

### TERMINAL FUNCTIONS

TERMINAL NAME	DESCRIPTION	ELECTRICAL CHARACTERISTICS
GND	Ground	Ground input
VCC	Power-supply voltage	1.8 V nominal
VREF	Input reference voltage	0.9 V nominal
CLK	Positive master clock input	Differential input
$\overline{\text{CLK}}$	Negative master clock input	Differential input
C0, C1	Configuration control input. Register A or Register B and 1:1 mode or 1:2 mode select.	LVC MOS input
$\overline{\text{RESET}}$	Asynchronous reset input. Resets registers and disables VREF, data, and clock differential-input receivers. When RESET is low, all Q outputs are forced low and the QERR output is forced high.	LVC MOS input
D1–D25	Data input. Clocked in on the crossing of the rising edge of CLK and the falling edge of $\overline{\text{CLK}}$ .	SSTL_18 inputs
$\overline{\text{CSR}}$ , $\overline{\text{DCS}}$	Chip select inputs. Disables D1–D25 <sup>†</sup> outputs switching when both inputs are high.	SSTL_18 inputs
DOT	The outputs of this register bit will not be suspended by the $\overline{\text{DCS}}$ and $\overline{\text{CSR}}$ control	SSTL_18 input
DCKE	The outputs of this register bit will not be suspended by the $\overline{\text{DCS}}$ and $\overline{\text{CSR}}$ control	SSTL_18 input
PAR_IN	Parity input. Arrives one clock cycle after the corresponding data input.	SSTL_18 input
Q1–Q25 <sup>‡</sup>	Data outputs that are suspended by the $\overline{\text{DCS}}$ and $\overline{\text{CSR}}$ control	1.8 V CMOS outputs
PPO	Partial parity out. Indicates odd parity of inputs D1–D25. <sup>†</sup>	1.8 V CMOS output
$\overline{\text{QCS}}$	Data output that will not be suspended by the $\overline{\text{DCS}}$ and $\overline{\text{CSR}}$ control	1.8 V CMOS output
QODT	Data output that will not be suspended by the $\overline{\text{DCS}}$ and $\overline{\text{CSR}}$ control	1.8 V CMOS output
QCKE	Data output that will not be suspended by the $\overline{\text{DCS}}$ and $\overline{\text{CSR}}$ control	1.8 V CMOS output
$\overline{\text{QERR}}$	Output error bit. Timing is determined by the device mode.	Open-drain output
NC	No internal connection	
DNU	Do not use. Inputs are in standby-equivalent mode, and outputs are driven low.	

<sup>†</sup> Data inputs = D2, D3, D5, D6, D8–D25 when C0 = 0 and C1 = 0

Data inputs = D2, D3, D5, D6, D8–D14 when C0 = 0 and C1 = 1

Data inputs = D1–D6, D8–D10, D12, D13 when C0 = 1 and C1 = 1.

<sup>‡</sup> Data outputs = Q2, Q3, Q5, Q6, Q8–Q25 when C0 = 0 and C1 = 0

Data outputs = Q2, Q3, Q5, Q6, Q8–Q14 when C0 = 0 and C1 = 1

Data outputs = Q1–Q6, Q8–Q10, Q12, Q13 when C0 = 1 and C1 = 1.

### FUNCTION TABLES

INPUTS						OUTPUTS
$\overline{\text{RESET}}$	$\overline{\text{DCS}}$	$\overline{\text{CSR}}$	CLK	$\overline{\text{CLK}}$	Dn	Qn
H	L	X	↑	↓	L	L
H	L	X	↑	↓	H	H
H	X	L	↑	↓	L	L
H	X	L	↑	↓	H	H
H	H	H	↑	↓	X	Q <sub>0</sub>
H	X	X	L or H	L or H	X	Q <sub>0</sub>
L	X or floating	X or floating	X or floating	X or floating	X or floating	L



**SN74SSTU32866A**  
**25-BIT CONFIGURABLE REGISTERED BUFFER**  
**WITH ADDRESS-PARITY TEST**

SCAS803A – JUNE 2005 – REVISED NOVEMBER 2007

**Function Tables (Continued)**

INPUTS				OUTPUTS
$\overline{\text{RESET}}$	CLK	$\overline{\text{CLK}}$	$\overline{\text{DCKE}},$ $\overline{\text{DCS}},$ $\overline{\text{DODT}}$	$\overline{\text{QCKE}},$ $\overline{\text{QCS}},$ $\overline{\text{QODT}}$
H	↑	↓	H	H
H	↑	↓	L	L
H	L or H	L or H	X	Q <sub>0</sub>
L	X or floating	X or floating	X or floating	L

**PARITY AND STANDBY FUNCTION**

INPUTS							OUTPUTS	
$\overline{\text{RESET}}$	CLK	$\overline{\text{CLK}}$	$\overline{\text{DCS}}$	$\overline{\text{CSR}}$	$\Sigma$ OF INPUTS = H D1–D25 <sup>†</sup>	PAR_IN <sup>‡</sup>	PPO	$\overline{\text{QERR}}^{\S}$
H	↑	↓	L	X	Even	L	L	H
H	↑	↓	L	X	Odd	L	H	L
H	↑	↓	L	X	Even	H	H	L
H	↑	↓	L	X	Odd	H	L	H
H	↑	↓	H	L	Even	L	L	H
H	↑	↓	H	L	Odd	L	H	L
H	↑	↓	H	L	Even	H	H	L
H	↑	↓	H	L	Odd	H	L	H
H	↑	↓	H	H	X	X	PPO <sub>0</sub>	$\overline{\text{QERR}}_0$
H	L or H	L or H	X	X	X	X	PPO <sub>0</sub>	$\overline{\text{QERR}}_0$
L	X or floating	X or floating	X or floating	X or floating	X	X or floating	L	H

<sup>†</sup> Data inputs = D2–D3, D5–D6, D8–D25 when C0 = 0 and C1 = 0

    Data inputs = D2–D3, D5–D6, D8–D14 when C0 = 0 and C1 = 1

    Data inputs = D1–D6, D8–D13 when C0 = 1 and C1 = 1

<sup>‡</sup> PAR\_IN arrives one clock cycle (C0 = 0) or two clock cycles (C0 = 1) after the data to which it applies.

<sup>§</sup> This transition assumes that  $\overline{\text{QERR}}$  is high at the crossing of CLK going high and  $\overline{\text{CLK}}$  going low. If  $\overline{\text{QERR}}$  goes low, then it stays latched low for a minimum of two clock cycles or until  $\overline{\text{RESET}}$  is driven low. If two or more consecutive parity errors occur, then the  $\overline{\text{QERR}}$  output is driven low and latched low for a clock duration equal to the parity duration or until  $\overline{\text{RESET}}$  is driven low.

# SN74SSTU32866A

## 25-BIT CONFIGURABLE REGISTERED BUFFER WITH ADDRESS-PARITY TEST

SCAS803A – JUNE 2005 – REVISED NOVEMBER 2007

### PARITY ERROR DETECT IN LOW-POWER MODE<sup>¶</sup>

INPUT-DATA ERROR OCCURANCE <sup>#</sup>	1:1 MODE (C0 = 0, C1 = 0)		1:2 REGISTER-A MODE (C0 = 0, C1 = 1)		1:2 REGISTER-B MODE (C0 = 1, C1 = 1)		CASCADED MODE (Registers A and B)	
	PPO DURATION <sup>  </sup>	$\overline{QERR}$ DURATION <sup>  </sup>	PPO DURATION <sup>  </sup>	$\overline{QERR}$ DURATION <sup>  </sup>	PPO DURATION <sup>  </sup>	$\overline{QERR}$ DURATION <sup>  </sup>	PPO DURATION <sup>  </sup>	$\overline{QERR}$ DURATION <sup>  </sup>
n - 4	1 Cycle	2 Cycles	1 Cycle	2 Cycles	1 Cycle	2 Cycles	1 Cycle	2 Cycles
n - 3	1 Cycle	2 Cycles	1 Cycle	2 Cycles	1 Cycle	2 Cycles	1 Cycle	2 Cycles
n - 2	1 Cycle	2 Cycles	1 Cycle	2 Cycles	1 Cycle	2 Cycles	1 Cycle	2 Cycles
n - 1	LPM + 2 Cycles	LPM + 2 Cycles	LPM + 1 Cycle	LPM + 1 Cycle	LPM + 2 Cycles	LPM + 2 Cycles	LPM + 2 Cycles	LPM + 2 Cycles
n	Not detected	Not detected	Not detected	Not detected	Not detected	Not detected	Not detected	Not detected

<sup>¶</sup> If a parity error occurs before the device enters the low-power mode (LPM), then the behavior of PPO and  $\overline{QERR}$  is dependent on the mode of the device and the position of the parity error occurrence. This table illustrates the low-power-mode effect on parity detect. The low-power mode is activated on the n clock cycle when  $\overline{DCS}$  and  $\overline{CSR}$  go high.

<sup>#</sup> The clock-edge position of a one cycle data-input error relative to the clock-edge (n) which initiates LPM at the  $\overline{DCS}$  and  $\overline{CSR}$  inputs.

<sup>||</sup> If an error occurs, then the  $\overline{QERR}$  output may be driven low and the PPO output driven high. These columns show the clock duration for which the PPO signal will be high.



# SN74SSTU32866A

## 25-BIT CONFIGURABLE REGISTERED BUFFER WITH ADDRESS-PARITY TEST

SCAS803A – JUNE 2005 – REVISED NOVEMBER 2007

### absolute maximum ratings over operating free-air temperature range (unless otherwise noted)†

Supply voltage range, $V_{CC}$	–0.5 V to 2.5 V
Input voltage range, $V_I$ (see Notes 1 and 2)	–0.5 V to 2.5 V
Output voltage range, $V_O$ (see Notes 1 and 2)	–0.5 V to $V_{CC} + 0.5$ V
Input clamp current, $I_{IK}$ ( $V_I < 0$ or $V_I > V_{CC}$ )	±50 mA
Output clamp current, $I_{OK}$ ( $V_O < 0$ or $V_O > V_{CC}$ )	±50 mA
Continuous output current, $I_O$ ( $V_O = 0$ to $V_{CC}$ )	±50 mA
Continuous current through each $V_{CC}$ or GND	±100 mA
Package thermal impedance, $\theta_{JA}$ (see Note 3)	36°C/W
Storage temperature range, $T_{stg}$	–65°C to 150°C

† Stresses beyond those listed under “absolute maximum ratings” may cause permanent damage to the device. These are stress ratings only, and functional operation of the device at these or any other conditions beyond those indicated under “recommended operating conditions” is not implied. Exposure to absolute-maximum-rated conditions for extended periods may affect device reliability.

- NOTES:
- The input and output negative-voltage ratings may be exceeded if the input and output clamp-current ratings are observed.
  - This value is limited to 2.5 V maximum.
  - The package thermal impedance is calculated in accordance with JESD 51-7.

### recommended operating conditions (see Note 4)

		MIN	NOM	MAX	UNIT	
$V_{CC}$	Supply voltage	1.7		1.9	V	
$V_{REF}$	Reference voltage	$0.49 \times V_{CC}$	$0.5 \times V_{CC}$	$0.51 \times V_{CC}$	V	
$V_{TT}$	Termination voltage	$V_{REF} - 40$ mV	$V_{REF}$	$V_{REF} + 40$ mV	V	
$V_I$	Input voltage	0		$V_{CC}$	V	
$V_{IH}$	AC high-level input voltage	Data inputs, $\overline{CSR}$ , $\overline{PAR\_IN}$		$V_{REF} + 250$ mV	V	
$V_{IL}$	AC low-level input voltage	Data inputs, $\overline{CSR}$ , $\overline{PAR\_IN}$		$V_{REF} - 250$ mV	V	
$V_{IH}$	DC high-level input voltage	Data inputs, $\overline{CSR}$ , $\overline{PAR\_IN}$		$V_{REF} + 125$ mV	V	
$V_{IL}$	DC low-level input voltage	Data inputs, $\overline{CSR}$ , $\overline{PAR\_IN}$		$V_{REF} - 125$ mV	V	
$V_{IH}$	High-level input voltage	$\overline{RESET}$ , $C_n$		$0.65 \times V_{CC}$	V	
$V_{IL}$	Low-level input voltage	$\overline{RESET}$ , $C_n$		$0.35 \times V_{CC}$	V	
$V_{ICR}$	Common-mode input voltage range	CLK, $\overline{CLK}$		0.675	1.125	V
$V_{I(PP)}$	Peak-to-peak input voltage	CLK, $\overline{CLK}$		600	mV	
$I_{OH}$	High-level output current	Q outputs, PPO		–8	8	mA
$I_{OL}$	Low-level output current	Q outputs, PPO		8	mA	
		QERR output		8		
$T_A$	Operating free-air temperature	0		70	°C	

NOTE 4: The  $\overline{RESET}$  and  $C_n$  inputs of the device must be held at valid logic voltage levels (not floating) to ensure proper device operation. The differential inputs must not be floating unless  $\overline{RESET}$  is low. Refer to the TI application report, *Implications of Slow or Floating CMOS Inputs*, literature number SCBA004.



# SN74SSTU32866A

## 25-BIT CONFIGURABLE REGISTERED BUFFER WITH ADDRESS-PARITY TEST

SCAS803A – JUNE 2005 – REVISED NOVEMBER 2007

electrical characteristics over recommended operating free-air temperature range (unless otherwise noted)

PARAMETER		TEST CONDITIONS	V <sub>CC</sub>	MIN	TYP†	MAX	UNIT	
V <sub>OH</sub>	Q outputs, PPO	I <sub>OH</sub> = -100 μA	1.7 V to 1.9 V	V <sub>CC</sub> -0.2		V		
		I <sub>OH</sub> = -6 mA	1.7 V	1.3				
V <sub>OL</sub>	Q outputs, PPO	I <sub>OL</sub> = 100 μA	1.7 V to 1.9 V			0.2	V	
		I <sub>OL</sub> = 6 mA	1.7 V			0.4		
	$\overline{\text{QERR}}$ output	I <sub>OL</sub> = 8 mA	1.7 V			0.35		
I <sub>I</sub>	All inputs‡	V <sub>I</sub> = V <sub>CC</sub> or GND	1.9 V			±5	μA	
I <sub>OZ</sub>	$\overline{\text{QERR}}$ output	V <sub>O</sub> = V <sub>CC</sub> or GND	1.9 V			±10	μA	
I <sub>CC</sub>	Static standby	$\overline{\text{RESET}}$ = GND	1.9 V			100	μA	
	Static operating	$\overline{\text{RESET}}$ = V <sub>CC</sub> , V <sub>I</sub> = V <sub>IH(AC)</sub> or V <sub>IL(AC)</sub>		I <sub>O</sub> = 0			50	mA
I <sub>CCD</sub>	Dynamic operating – clock only	$\overline{\text{RESET}}$ = V <sub>CC</sub> , V <sub>I</sub> = V <sub>IH(AC)</sub> or V <sub>IL(AC)</sub> , CLK and $\overline{\text{CLK}}$ switching 50% duty cycle	1.8 V			43	μA/MHz	
	Dynamic operating – per each data input, 1:1 configuration	$\overline{\text{RESET}}$ = V <sub>CC</sub> , V <sub>I</sub> = V <sub>IH(AC)</sub> or V <sub>IL(AC)</sub> , CLK and $\overline{\text{CLK}}$ switching 50% duty cycle, one data input switching at one-half clock frequency, 50% duty cycle		I <sub>O</sub> = 0			25	μA/clock MHz/D input
	Dynamic operating – per each data input, 1:2 configuration	$\overline{\text{RESET}}$ = V <sub>CC</sub> , V <sub>I</sub> = V <sub>IH(AC)</sub> or V <sub>IL(AC)</sub> , CLK and $\overline{\text{CLK}}$ switching 50% duty cycle, one data input switching at one-half clock frequency, 50% duty cycle		I <sub>O</sub> = 0			49	μA/clock MHz/D input
I <sub>CCDLP</sub>	Chip-select-enabled low-power active mode – clock only	$\overline{\text{RESET}}$ = V <sub>CC</sub> , V <sub>I</sub> = V <sub>IH(AC)</sub> or V <sub>IL(AC)</sub> , CLK and $\overline{\text{CLK}}$ switching 50% duty cycle	1.8 V			46	μA/MHz	
	Chip-select-enabled low-power active mode – 1:1 configuration	$\overline{\text{RESET}}$ = V <sub>CC</sub> , V <sub>I</sub> = V <sub>IH(AC)</sub> or V <sub>IL(AC)</sub> , CLK and $\overline{\text{CLK}}$ switching 50% duty cycle, one data input switching at one-half clock frequency, 50% duty cycle		I <sub>O</sub> = 0			2	μA/clock MHz/D input
	Chip-select-enabled low-power active mode – 1:2 configuration	$\overline{\text{RESET}}$ = V <sub>CC</sub> , V <sub>I</sub> = V <sub>IH(AC)</sub> or V <sub>IL(AC)</sub> , CLK and $\overline{\text{CLK}}$ switching 50% duty cycle, one data input switching at one-half clock frequency, 50% duty cycle		I <sub>O</sub> = 0			2	μA/clock MHz/D input
C <sub>i</sub>	Data inputs, $\overline{\text{CSR}}$ , $\overline{\text{PAR\_IN}}$	V <sub>I</sub> = V <sub>REF</sub> ± 250 mV	1.8 V	2.5	3	3.5	pF	
	CLK, $\overline{\text{CLK}}$	V <sub>ICR</sub> = 0.9 V, V <sub>I(PP)</sub> = 600 mV		2	3			
	$\overline{\text{RESET}}$	V <sub>I</sub> = V <sub>CC</sub> or GND		2.5				

† All typical values are at V<sub>CC</sub> = 1.8 V, T<sub>A</sub> = 25°C.

‡ Each V<sub>REF</sub> pin (A3 or T3) must be tested independently, with the other (untested) pin open. Since the two V<sub>REF</sub> pins are connected internally, the total maximum current on the V<sub>REF</sub> pin is doubled (±10 μA).



**SN74SSTU32866A**  
**25-BIT CONFIGURABLE REGISTERED BUFFER**  
**WITH ADDRESS-PARITY TEST**

SCAS803A – JUNE 2005 – REVISED NOVEMBER 2007

**timing requirements over recommended operating free-air temperature range (unless otherwise noted) (see Figure 1 and Note 5)**

		$V_{CC} = 1.8\text{ V} \pm 0.1\text{ V}$		UNIT	
		MIN	MAX	UNIT	
$f_{\text{clock}}$	Clock frequency	500		MHz	
$t_w$	Pulse duration, CLK, $\overline{\text{CLK}}$ high or low	1		ns	
$t_{\text{act}}$	Differential inputs active time (see Note 6)	10		ns	
$t_{\text{inact}}$	Differential inputs inactive time (see Note 7)	15		ns	
$t_{\text{su}}$	Setup time	$\overline{\text{DCS}}$ before CLK $\uparrow$ , $\overline{\text{CLK}}\downarrow$ , $\overline{\text{CSR}}$ high; $\overline{\text{CSR}}$ before CLK $\uparrow$ , $\overline{\text{CLK}}\downarrow$ , $\overline{\text{DCS}}$ high		0.6	ns
		$\overline{\text{DCS}}$ before CLK $\uparrow$ , $\overline{\text{CLK}}\downarrow$ , $\overline{\text{CSR}}$ low		0.5	
		DODT, DCKE, and Data before CLK $\uparrow$ , $\overline{\text{CLK}}\downarrow$		0.5	
		PAR_IN before CLK $\uparrow$ , $\overline{\text{CLK}}\downarrow$		0.5	
$t_h$	Hold time	$\overline{\text{DCS}}$ , DODT, DCKE, and Data after CLK $\uparrow$ , $\overline{\text{CLK}}\downarrow$		0.5	ns
		PAR_IN after CLK $\uparrow$ , $\overline{\text{CLK}}\downarrow$		0.5	

- NOTES: 5. All inputs slew rate is 1 V/ns  $\pm$  20%.  
6.  $V_{\text{REF}}$  must be held at a valid input level, and data inputs must be held low for a minimum time of  $t_{\text{act}}$  max, after  $\overline{\text{RESET}}$  is taken high.  
7.  $V_{\text{REF}}$ , data, and clock inputs must be held at valid voltage levels (not floating) for a minimum time of  $t_{\text{inact}}$  max, after  $\overline{\text{RESET}}$  is taken low.

**switching characteristics over recommended operating free-air temperature range (unless otherwise noted)**

PARAMETER		FROM (INPUT)	TO (OUTPUT)	$V_{CC} = 1.8\text{ V} \pm 0.1\text{ V}$		UNIT
				MIN	MAX	
$f_{\text{max}}$ (see Figure 1)				500		MHz
$t_{\text{pdm}}^\dagger$ (see Figure 1)		CLK and $\overline{\text{CLK}}$	Q	1.41	2.15	ns
$t_{\text{pd}}$	see Figure 4	CLK and $\overline{\text{CLK}}$	PPO	0.4	1.7	ns
$t_{\text{PLH}}$	see Figure 3	CLK and $\overline{\text{CLK}}$	$\overline{\text{QERR}}$	0.7	2.5	ns
$t_{\text{PHL}}$				0.7	2.1	
$t_{\text{pdmss}}^\dagger$ (see Figure 1)		CLK and $\overline{\text{CLK}}$	Q	2.35		ns
$t_{\text{RPHL}}^\dagger$ (see Figure 1)		$\overline{\text{RESET}}$	Q	3		ns
$t_{\text{RPHL}}$ (see Figure 4)			PPO	3		
$t_{\text{RPLH}}$ (see Figure 3)			$\overline{\text{QERR}}$	3		ns

$^\dagger$  Includes 350-ps test-load transmission-line delay.

**output slew rates over recommended operating free-air temperature range (unless otherwise noted) (see Figure 2)**

PARAMETER	FROM	TO	$V_{CC} = 1.8\text{ V} \pm 0.1\text{ V}$		UNIT
			MIN	MAX	
$dV/dt_r$	20%	80%	1	4	V/ns
$dV/dt_f$	80%	20%	1	4	V/ns
$dV/dt_{\Delta}^\ddagger$	20% or 80%	80% or 20%	1		V/ns

$^\ddagger$  Difference between  $dV/dt_r$  (rising edge rate) and  $dV/dt_f$  (falling edge rate).



# SN74SSTU32866A

## 25-BIT CONFIGURABLE REGISTERED BUFFER WITH ADDRESS-PARITY TEST

SCAS803A – JUNE 2005 – REVISED NOVEMBER 2007

### PARAMETER MEASUREMENT INFORMATION

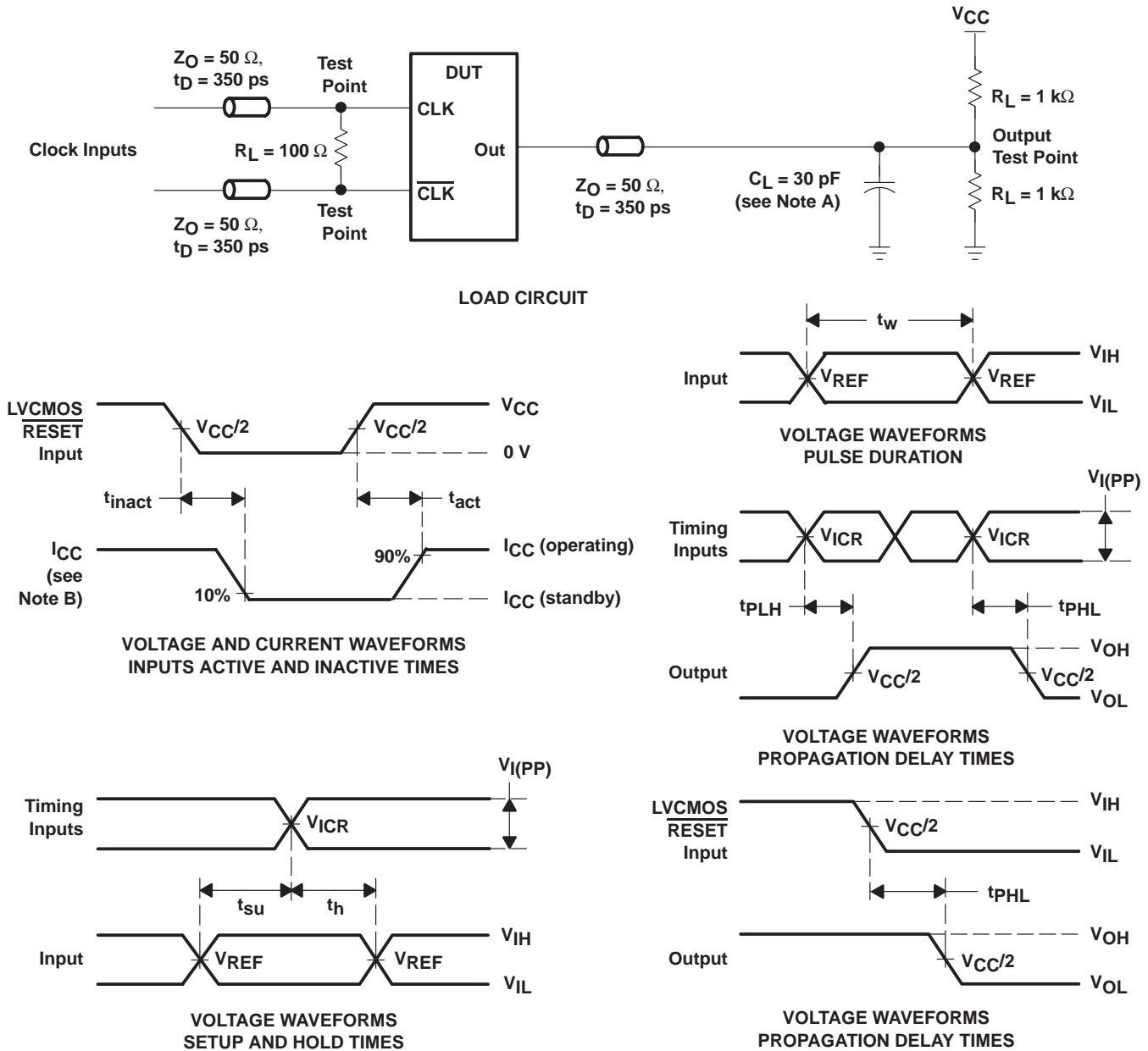

- NOTES:
- $C_L$  includes probe and jig capacitance.
  - $I_{CC}$  tested with clock and data inputs held at  $V_{CC}$  or GND, and  $I_O = 0\ \text{mA}$ .
  - All input pulses are supplied by generators having the following characteristics:  $\text{PRR} \leq 10\ \text{MHz}$ ,  $Z_O = 50\ \Omega$ , input slew rate =  $1\ \text{V/ns} \pm 20\%$  (unless otherwise noted).
  - The outputs are measured one at a time, with one transition per measurement.
  - $V_{REF} = V_{TT} = V_{CC}/2$
  - $V_{IH} = V_{REF} + 250\ \text{mV}$  (ac voltage levels) for differential inputs.  $V_{IH} = V_{CC}$  for LVC MOS input.
  - $V_{IL} = V_{REF} - 250\ \text{mV}$  (ac voltage levels) for differential inputs.  $V_{IL} = \text{GND}$  for LVC MOS input.
  - $V_{I(PP)} = 600\ \text{mV}$
  - $t_{PLH}$  and  $t_{PHL}$  are the same as  $t_{pd}$ .

Figure 1. Data Output Load Circuit and Voltage Waveforms

**PARAMETER MEASUREMENT INFORMATION**

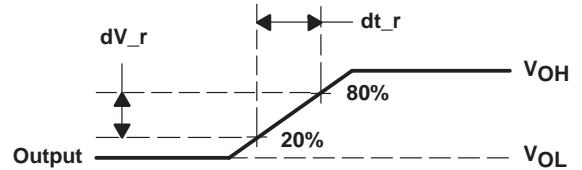
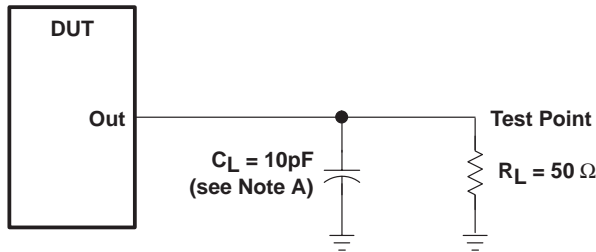
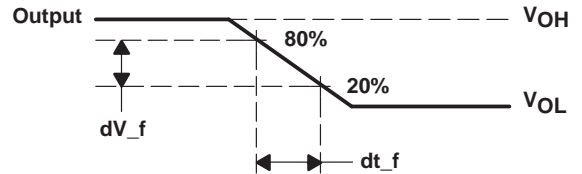
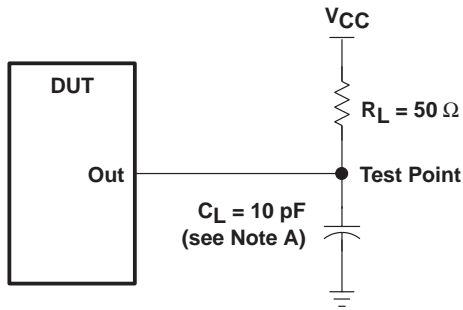

- NOTES: A.  $C_L$  includes probe and jig capacitance.  
 B. All input pulses are supplied by generators having the following characteristics: PRR  $\leq$  10 MHz,  $Z_O = 50 \Omega$ , input slew rate = 1 V/ns  $\pm$  20% (unless otherwise specified).

**Figure 2. Data Output Slew-Rate Measurement Information**

**SN74SSTU32866A**  
**25-BIT CONFIGURABLE REGISTERED BUFFER**  
**WITH ADDRESS-PARITY TEST**

SCAS803A – JUNE 2005 – REVISED NOVEMBER 2007

**PARAMETER MEASUREMENT INFORMATION**

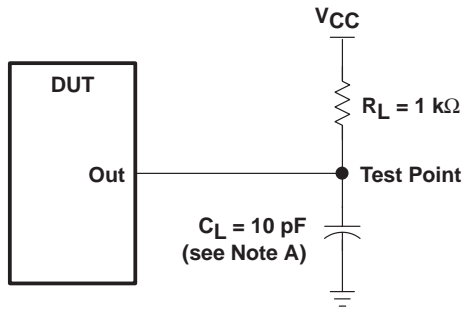

**LOAD CIRCUIT**

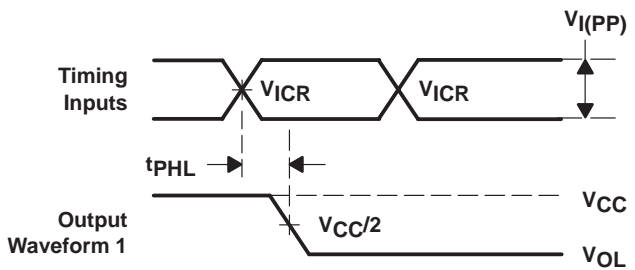

**VOLTAGE WAVEFORMS**  
**OPEN-DRAIN OUTPUT TRANSITION TIME**  
**(HIGH-TO-LOW)**

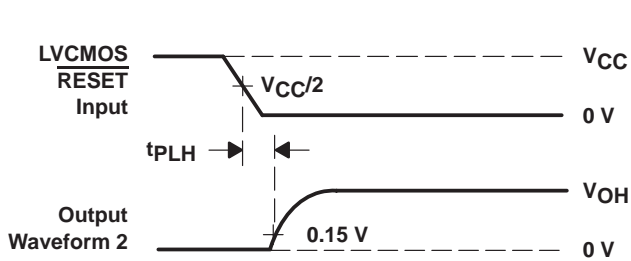

**VOLTAGE WAVEFORMS**  
**OPEN-DRAIN OUTPUT TRANSITION TIME**  
**(LOW-TO-HIGH)**

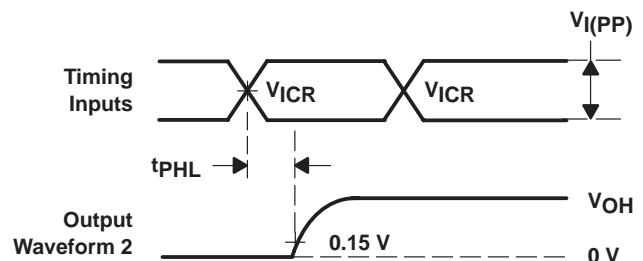

**VOLTAGE WAVEFORMS**  
**OPEN-DRAIN OUTPUT TRANSITION TIME**  
**(LOW-TO-HIGH)**

- NOTES: A.  $C_L$  includes probe and jig capacitance.  
 B. All input pulses are supplied by generators having the following characteristics:  $PRR \leq 10\text{ MHz}$ ,  $Z_O = 50\ \Omega$ , input slew rate =  $1\text{ V/ns} \pm 20\%$  (unless otherwise noted).  
 C.  $t_{PLH}$  and  $t_{PHL}$  are the same as  $t_{pd}$ .

**Figure 3. Error Output Load Circuit and Voltage Waveforms**

**PARAMETER MEASUREMENT INFORMATION**

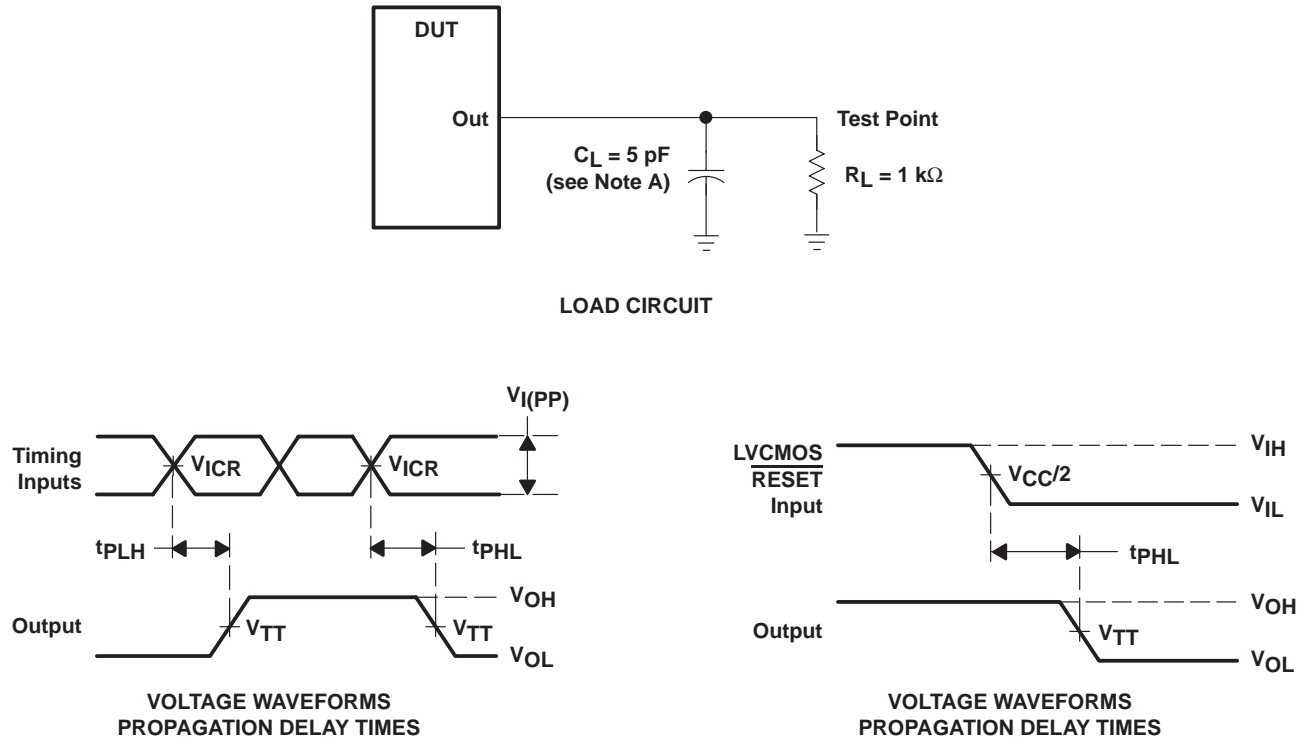

- NOTES:
- A.  $C_L$  includes probe and jig capacitance.
  - B. All input pulses are supplied by generators having the following characteristics:  $PRR \leq 10$  MHz,  $Z_O = 50 \Omega$ , input slew rate =  $1$  V/ns  $\pm 20\%$  (unless otherwise noted).
  - C.  $V_{REF} = V_{TT} = V_{CC}/2$
  - D.  $V_{IH} = V_{REF} + 250$  mV (ac voltage levels) for differential inputs.  $V_{IH} = V_{CC}$  for LVC MOS input.
  - E.  $V_{IL} = V_{REF} - 250$  mV (ac voltage levels) for differential inputs.  $V_{IL} = GND$  for LVC MOS input.
  - F.  $V_{I(PP)} = 600$  mV
  - G.  $t_{PLH}$  and  $t_{PHL}$  are the same as  $t_{pd}$ .

**Figure 4. Partial-Parity-Out Load Circuit and Voltage Waveforms**



# SN74SSTU32866A

## 25-BIT CONFIGURABLE REGISTERED BUFFER WITH ADDRESS-PARITY TEST

SCAS803A – JUNE 2005 – REVISED NOVEMBER 2007

timing diagram for SN74SSTU32866A used as a single device; C0 = 0, C1 = 0  
(RESET switches from L to H)

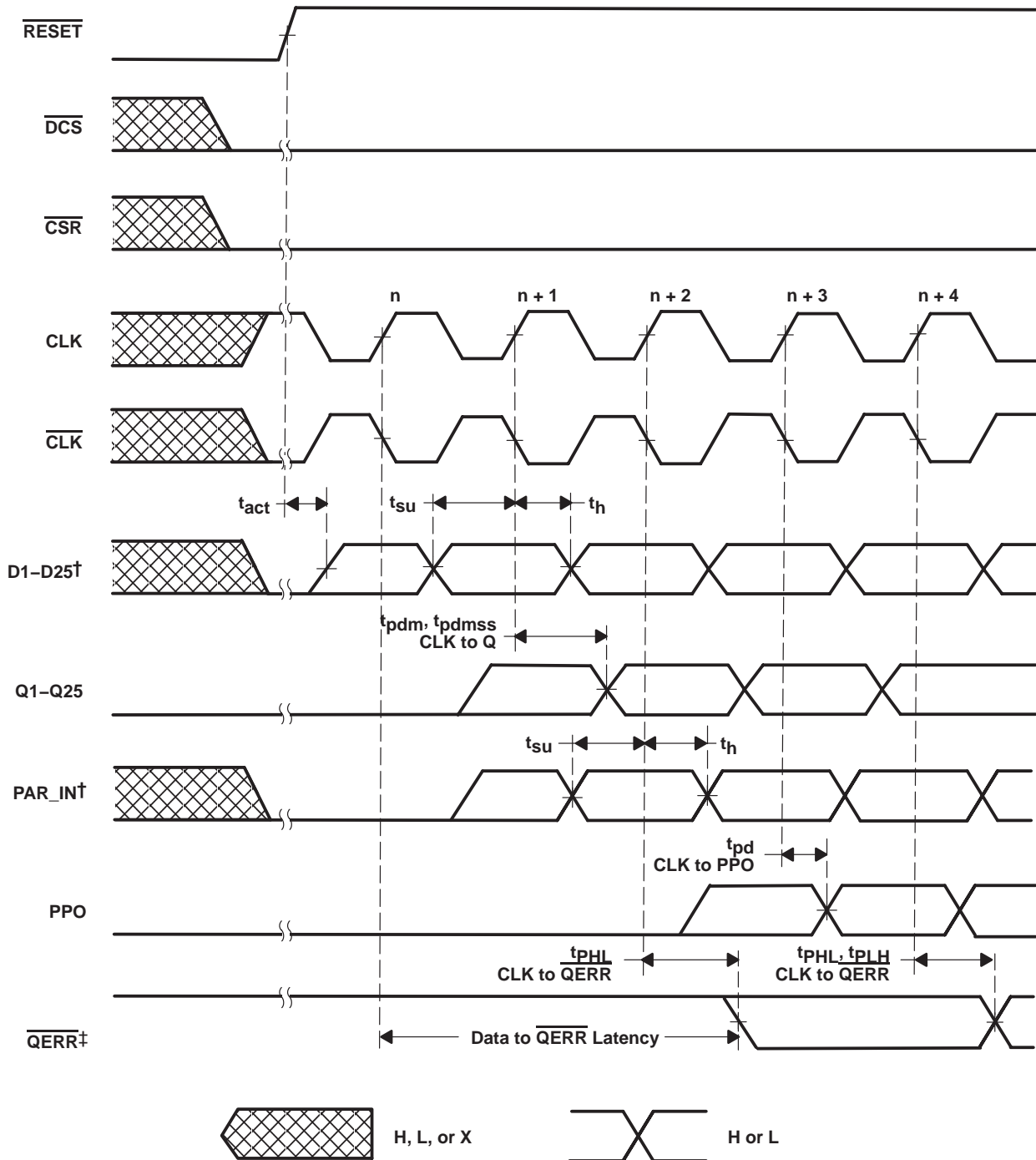

† After RESET is switched from low to high, all data and PAR\_IN input signals must be set and held low for a minimum time of  $t_{act}$  max, to avoid false error.

‡ If the data is clocked in on the n clock pulse, then the QERR output signal will be generated on the n + 2 clock pulse, and it will be valid on the n + 3 clock pulse.

# SN74SSTU32866A

## 25-BIT CONFIGURABLE REGISTERED BUFFER WITH ADDRESS-PARITY TEST

SCAS803A – JUNE 2005 – REVISED NOVEMBER 2007

timing diagram for SN74SSTU32866A used as a single device; C0 = 0, C1 = 0  
(RESET = H)

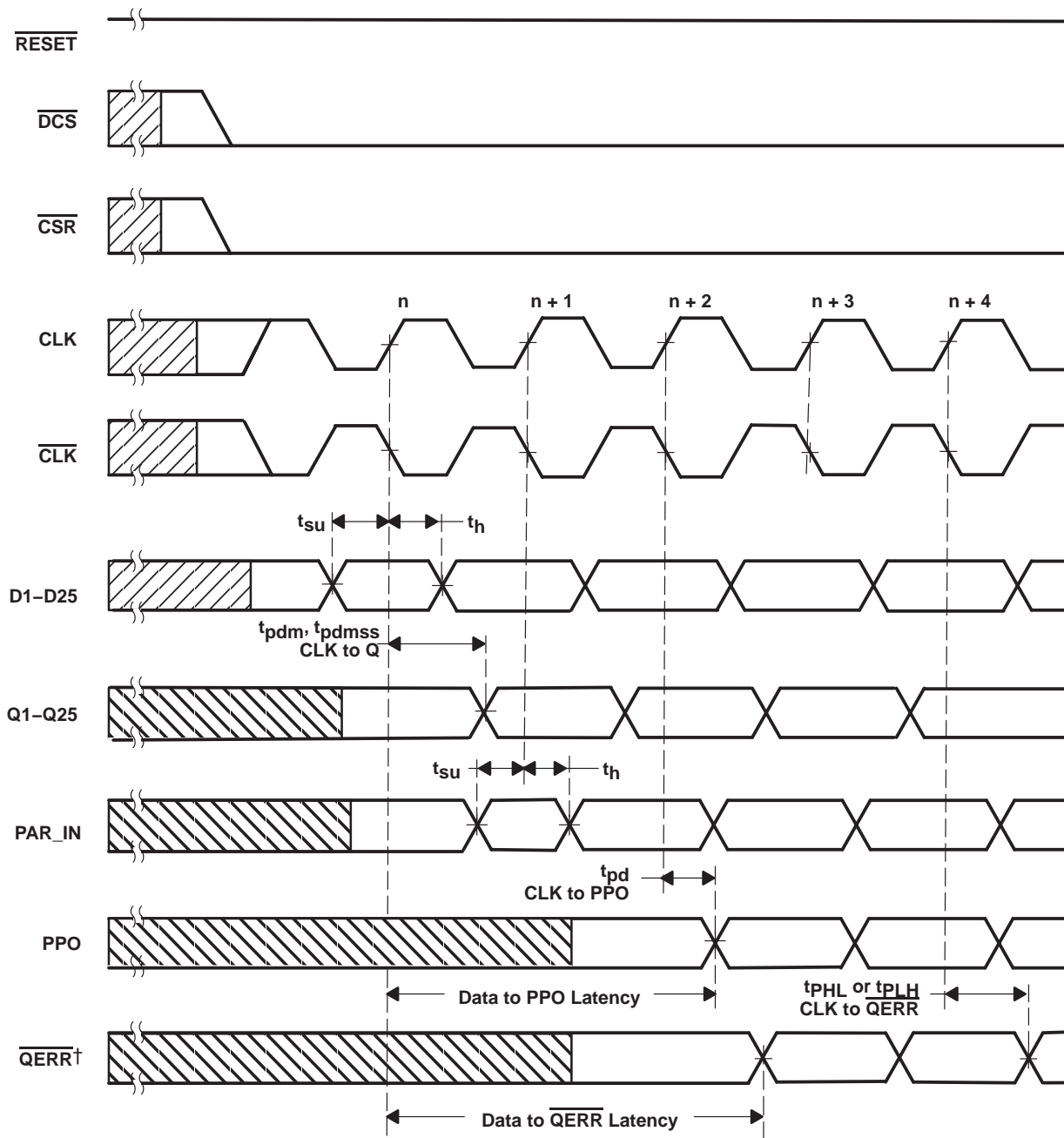

 Unknown input event

 Output signal is dependent on the prior unknown input event

 H or L

† If the data is clocked in on the n clock pulse, then the QERR output signal will be generated on the n + 2 clock pulse, and it will be valid on n + 3 clock pulse. If an error occurs and the QERR output is driven low, then it stays latched low for a minimum of two clock cycles or until RESET is driven low.



# SN74SSTU32866A 25-BIT CONFIGURABLE REGISTERED BUFFER WITH ADDRESS-PARITY TEST

SCAS803A – JUNE 2005 – REVISED NOVEMBER 2007

timing diagram for SN74SSTU32866A used as a single device; C0 = 0, C1 = 0  
(RESET switches from H to L)

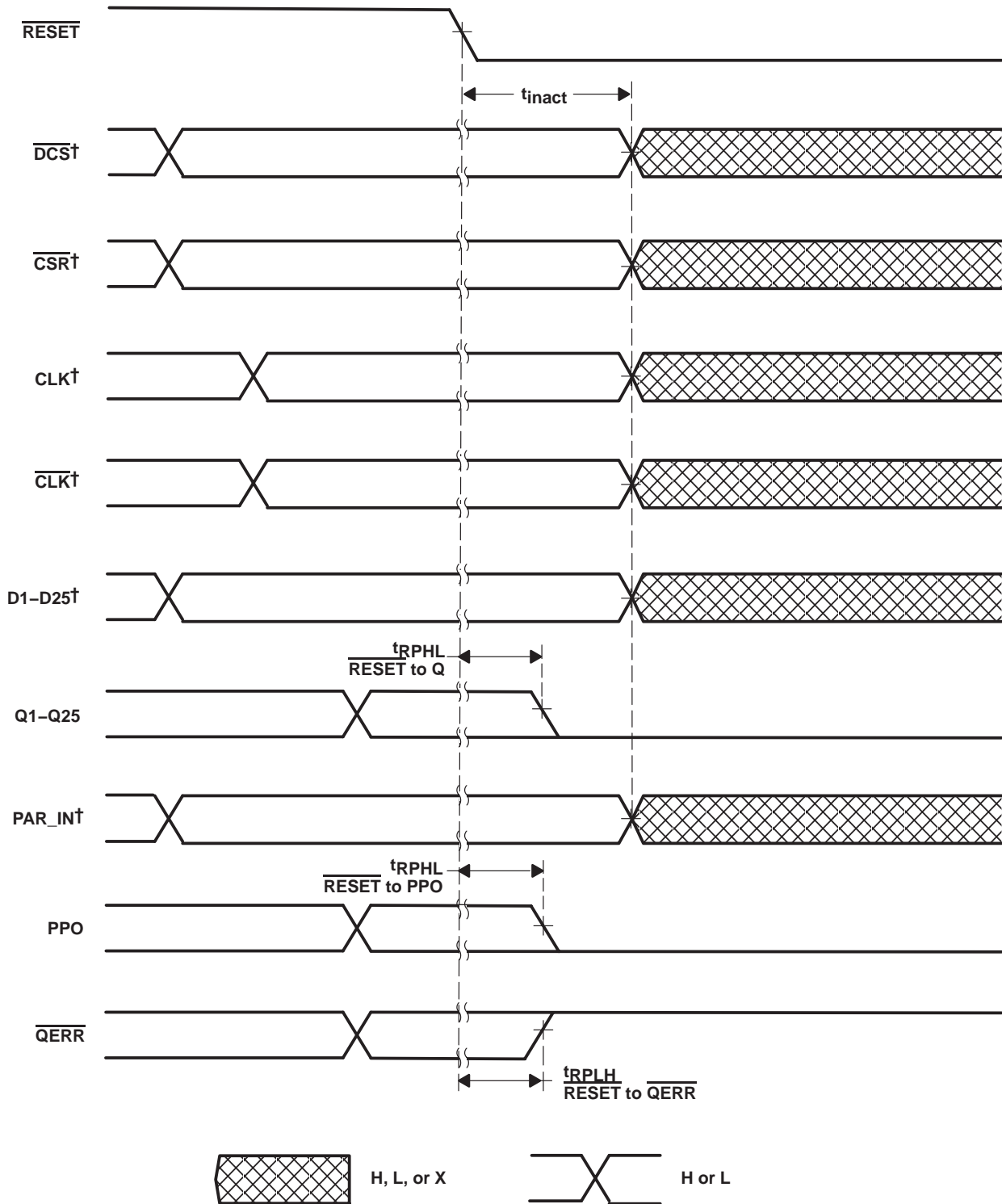

† After  $\overline{\text{RESET}}$  is switched from high to low, all data and clock input signals must be held at valid logic levels (not floating) for a minimum time of  $t_{inact}$  max.

# SN74SSTU32866A 25-BIT CONFIGURABLE REGISTERED BUFFER WITH ADDRESS-PARITY TEST

SCAS803A – JUNE 2005 – REVISED NOVEMBER 2007

## SN74SSTU32866A used in pair in the 1:2 register configuration

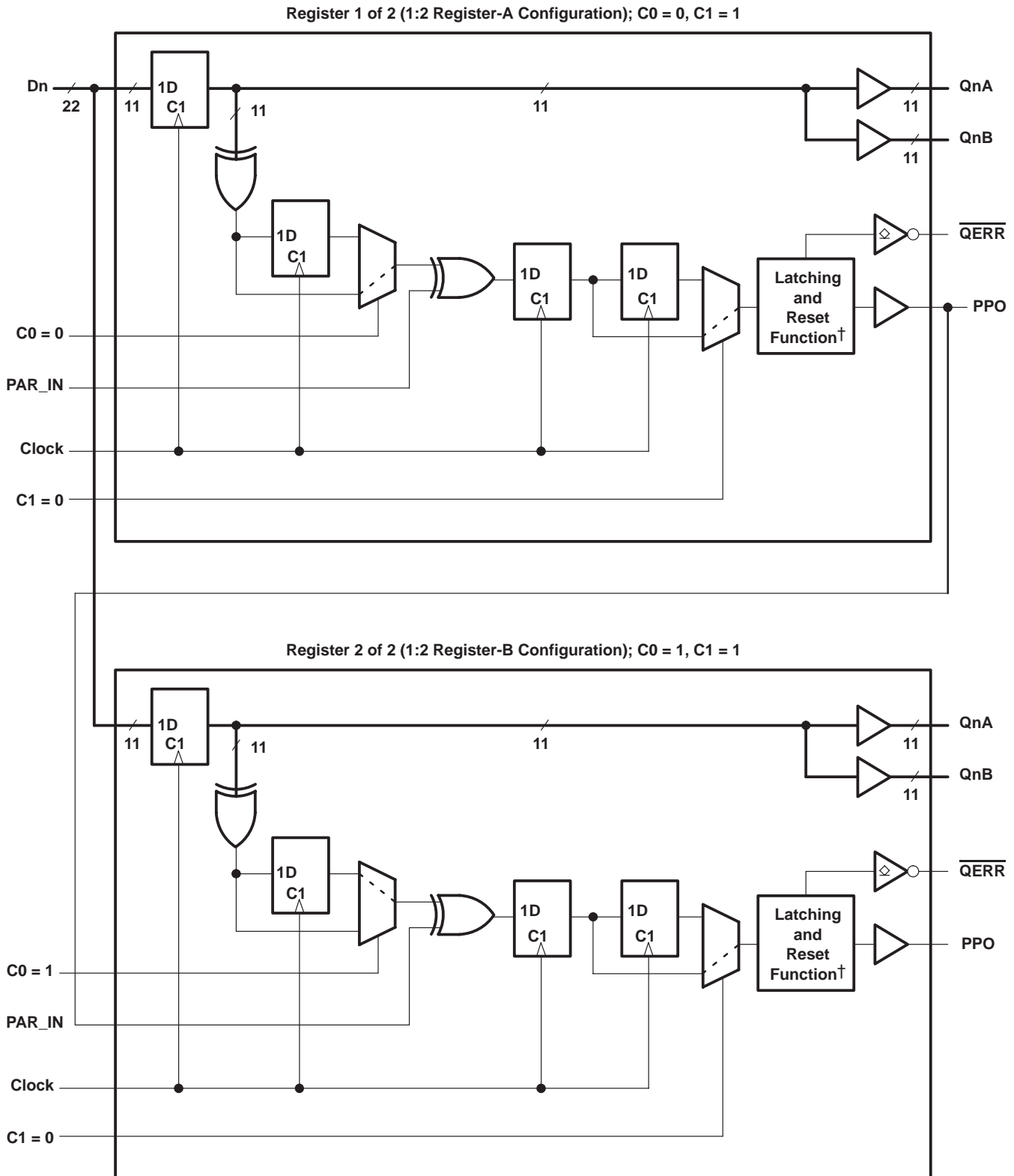

† This function holds the error for two cycles. For details, see the parity logic diagram.

# SN74SSTU32866A 25-BIT CONFIGURABLE REGISTERED BUFFER WITH ADDRESS-PARITY TEST

SCAS803A – JUNE 2005 – REVISED NOVEMBER 2007

timing diagram for the first SN74SSTU32866A (1:2 Register-A configuration) device used in pair;  
C0 = 0, C1 = 1 (RESET switches from L to H)

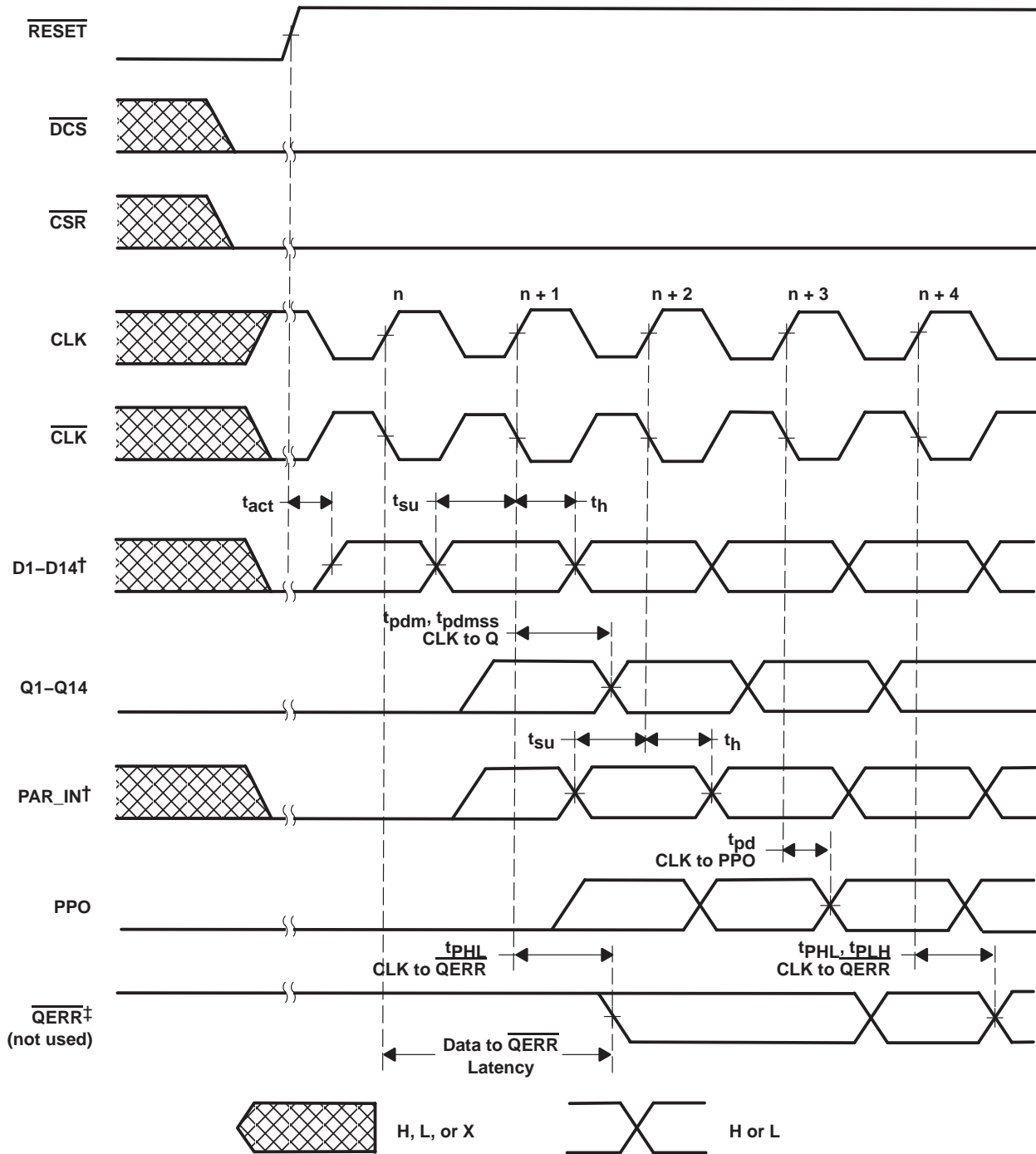

† After  $\overline{\text{RESET}}$  is switched from low to high, all data and  $\overline{\text{PAR\_IN}}$  input signals must be set and held low for a minimum time of  $t_{\text{act}}$  max, to avoid false error.

‡ If the data is clocked in on the  $n$  clock pulse, then the  $\overline{\text{QERR}}$  output signal will be generated on the  $n + 1$  clock pulse, and it will be valid on the  $n + 2$  clock pulse.

# SN74SSTU32866A 25-BIT CONFIGURABLE REGISTERED BUFFER WITH ADDRESS-PARITY TEST

SCAS803A – JUNE 2005 – REVISED NOVEMBER 2007

timing diagram for the first SN74SSTU32866A (1:2 Register-A configuration) device used in pair;  
C0 = 0, C1 = 1 (RESET = H)

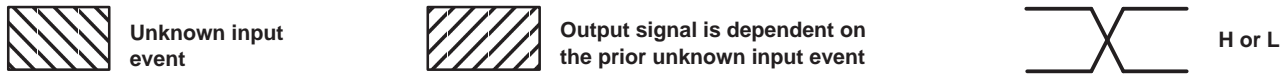
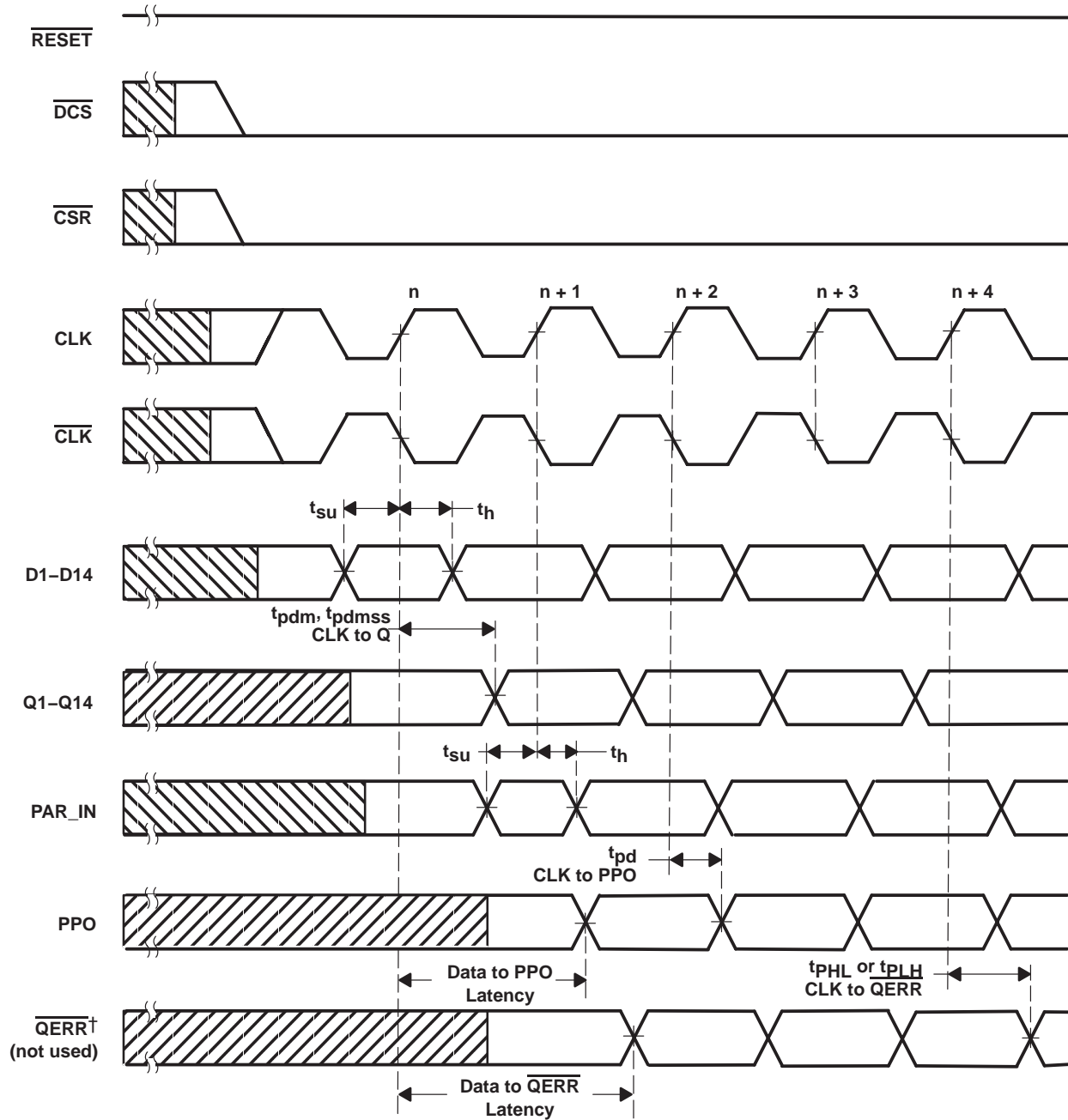

† If the data is clocked in on the n clock pulse, then the QERR output signal will be generated on the n + 1 clock pulse, and it will be valid on n + 2 clock pulse. If an error occurs and the QERR output is driven low, then it stays latched low for a minimum of two clock cycles or until RESET is driven low.

# SN74SSTU32866A 25-BIT CONFIGURABLE REGISTERED BUFFER WITH ADDRESS-PARITY TEST

SCAS803A – JUNE 2005 – REVISED NOVEMBER 2007

timing diagram for the first SN74SSTU32866A (1:2 Register-A configuration) device used in pair;  
C0 = 0, C1 = 1 (RESET switches from H to L)

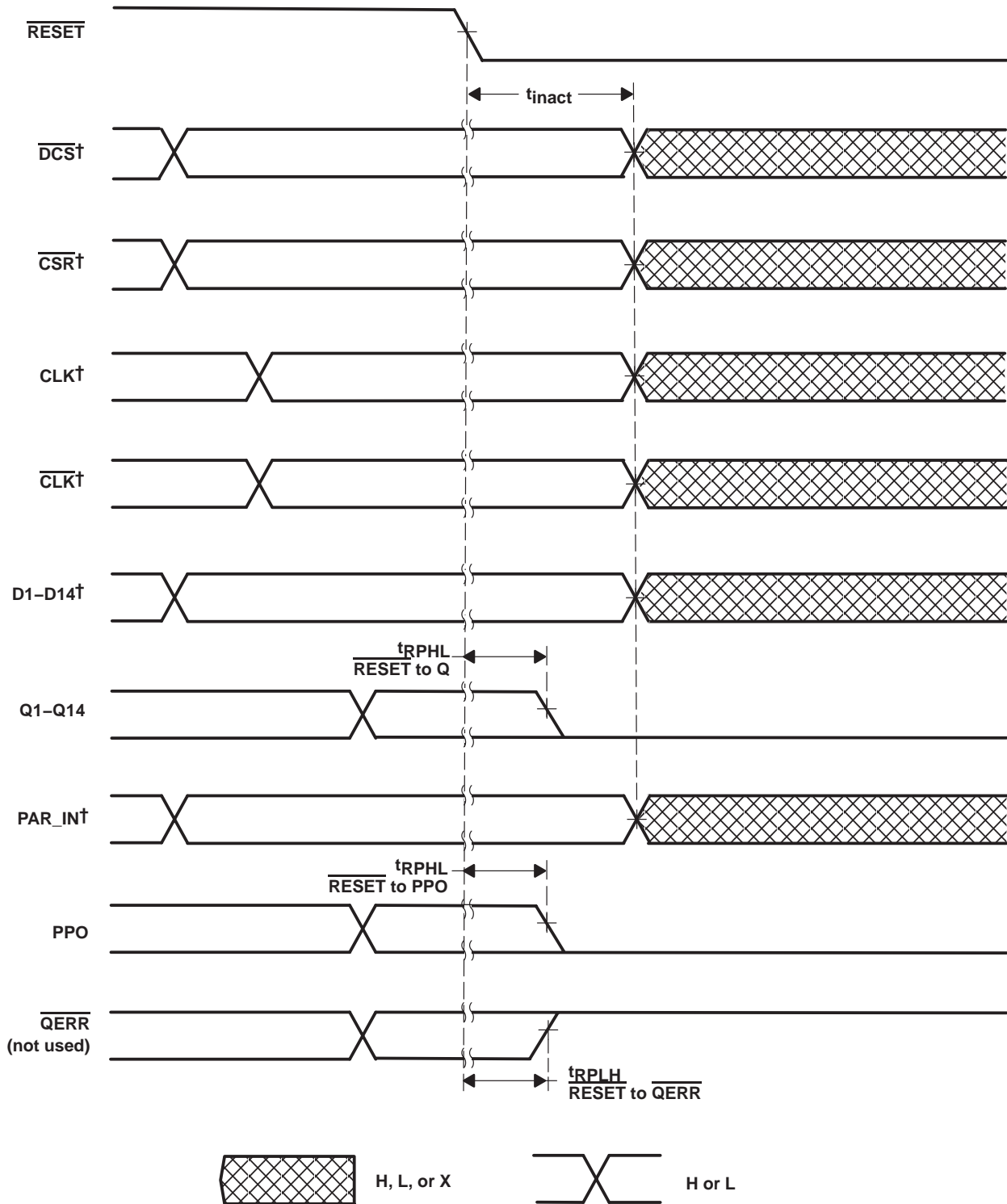

† After  $\overline{\text{RESET}}$  is switched from high to low, all data and clock input signals must be held at valid logic levels (not floating) for a minimum time of  $t_{\text{inact}}$  max.

# SN74SSTU32866A 25-BIT CONFIGURABLE REGISTERED BUFFER WITH ADDRESS-PARITY TEST

SCAS803A – JUNE 2005 – REVISED NOVEMBER 2007

timing diagram for the second SN74SSTU32866A (1:2 Register-B configuration) device used in pair; C0 = 1, C1 = 1 (RESET switches from L to H)

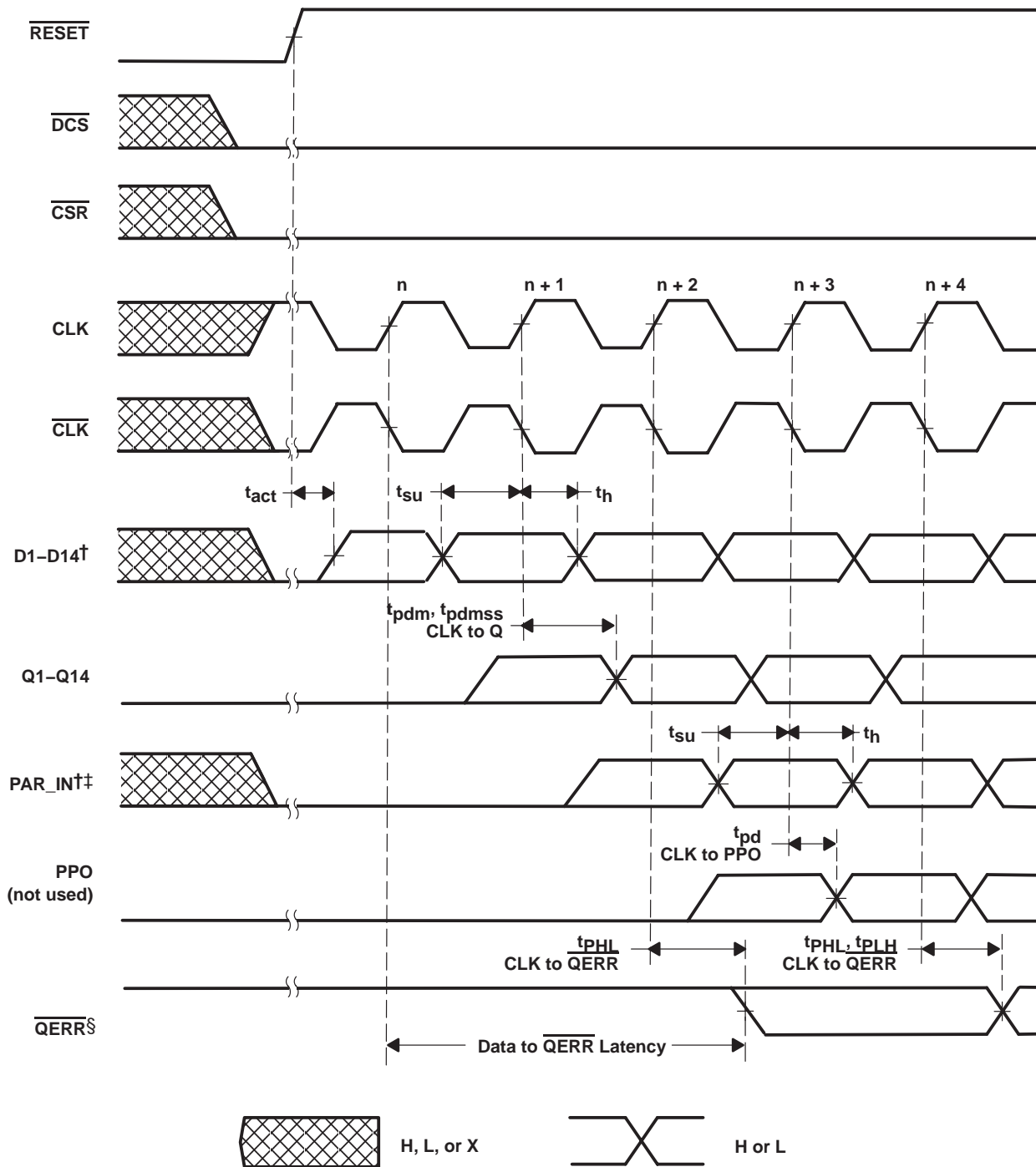

† After RESET is switched from low to high, all data and PAR\_IN input signals must be set and held low for a minimum time of  $t_{act}$  max, to avoid false error.

‡ PAR\_IN is driven from PPO of the first SN74SSTU32866A device.

§ If the data is clocked in on the n clock pulse, then the QERR output signal will be generated on the n + 2 clock pulse, and it will be valid on the n + 3 clock pulse.

# SN74SSTU32866A 25-BIT CONFIGURABLE REGISTERED BUFFER WITH ADDRESS-PARITY TEST

SCAS803A – JUNE 2005 – REVISED NOVEMBER 2007

timing diagram for the second SN74SSTU32866A (1:2 Register-B configuration) device used in pair; C0 = 1, C1 = 1 (RESET = H)

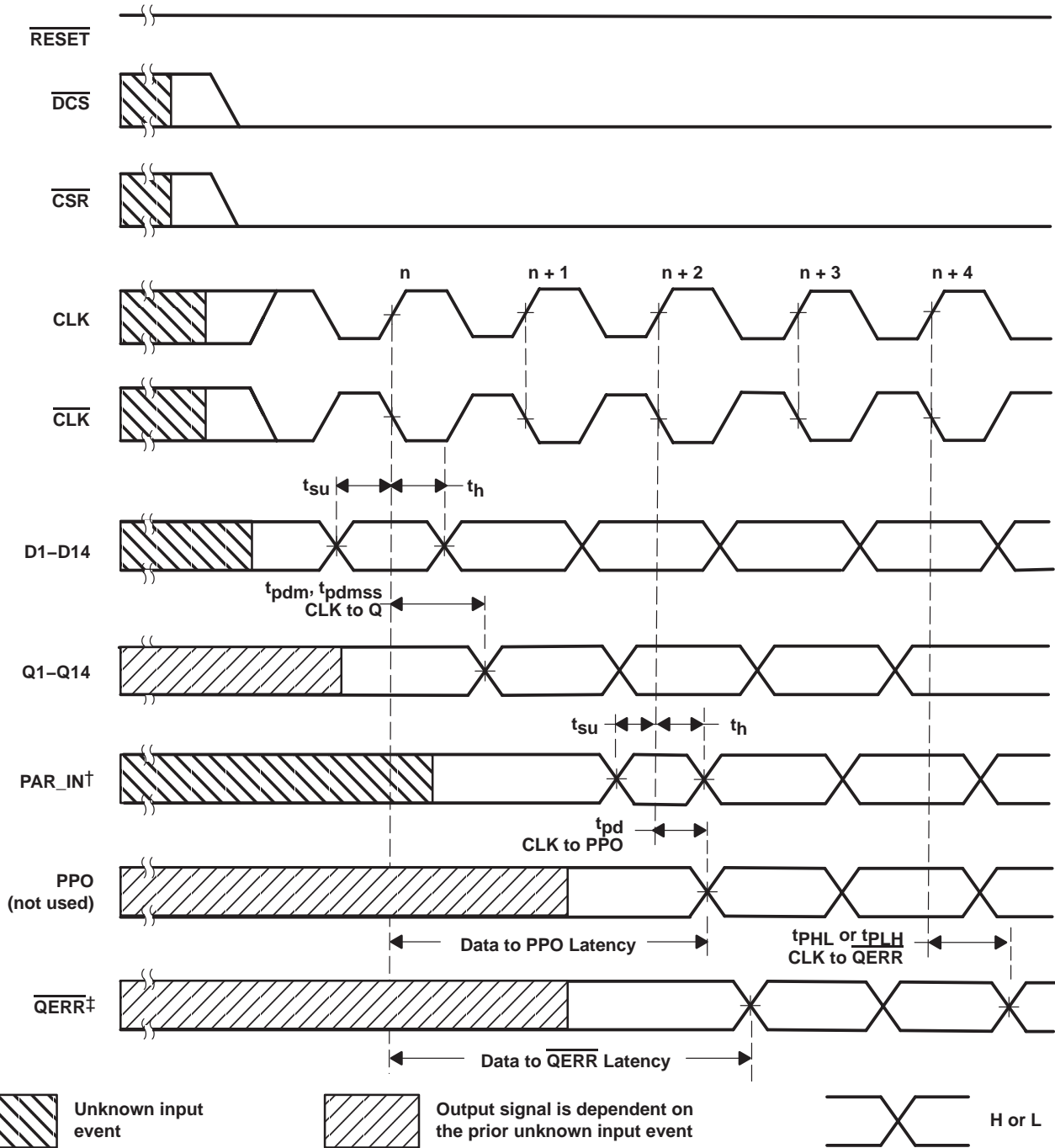

† PAR\_IN is driven from PPO of the first SN74SSTU32866A device.

‡ If the data is clocked in on the n clock pulse, then the QERR output signal will be generated on the n + 2 clock pulse, and it will be valid on n + 3 clock pulse. If an error occurs and the QERR output is driven low, then it stays latched low for a minimum of two clock cycles or until RESET is driven low.

# SN74SSTU32866A 25-BIT CONFIGURABLE REGISTERED BUFFER WITH ADDRESS-PARITY TEST

SCAS803A – JUNE 2005 – REVISED NOVEMBER 2007

timing diagram for the second SN74SSTU32866A (1:2 Register-B configuration) device used in pair; C0 = 1, C1 = 1 (RESET switches from H to L)

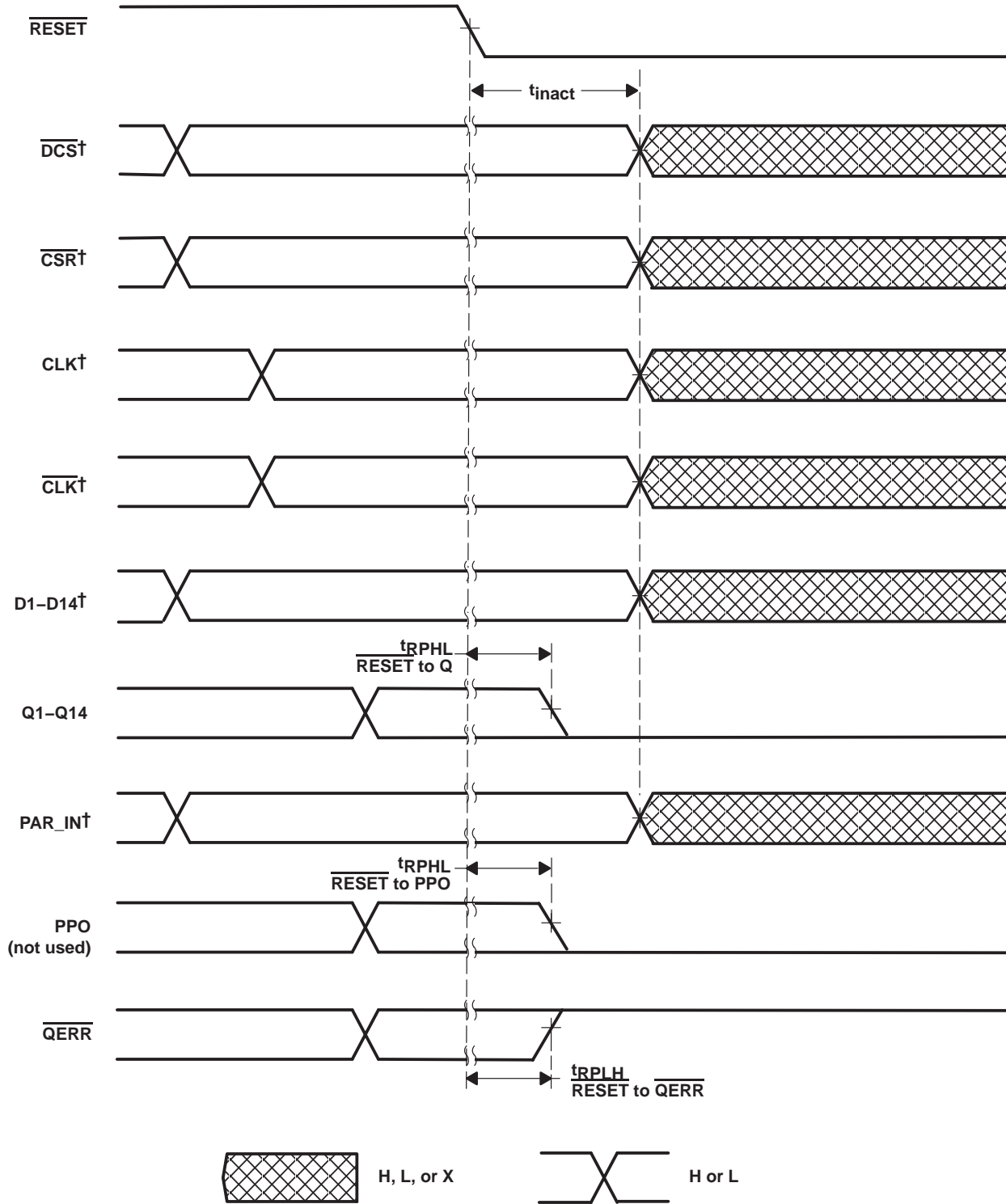

† After  $\overline{\text{RESET}}$  is switched from high to low, all data and clock input signals must be held at valid logic levels (not floating) for a minimum time of  $t_{\text{inact}}$  max.



GKE (R-PBGA-N96)

PLASTIC BALL GRID ARRAY

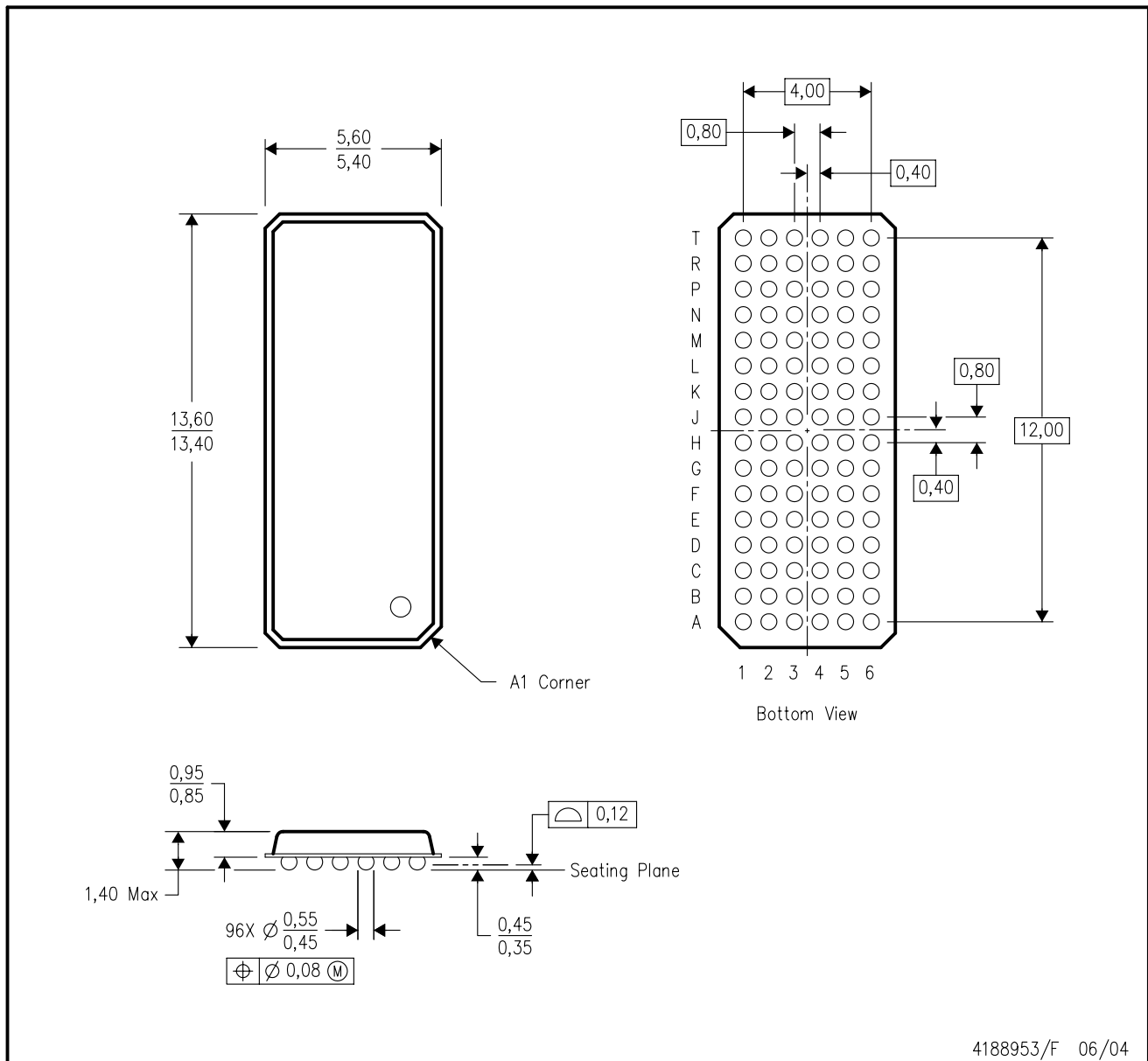

- NOTES:
- A. All linear dimensions are in millimeters.
  - B. This drawing is subject to change without notice.
  - C. Falls within JEDEC MO-205 variation CC.
  - D. This package is tin-lead (SnPb). Refer to the 96 ZKE package (drawing 4204493) for lead-free.

ZKE (R-PBGA-N96)

PLASTIC BALL GRID ARRAY

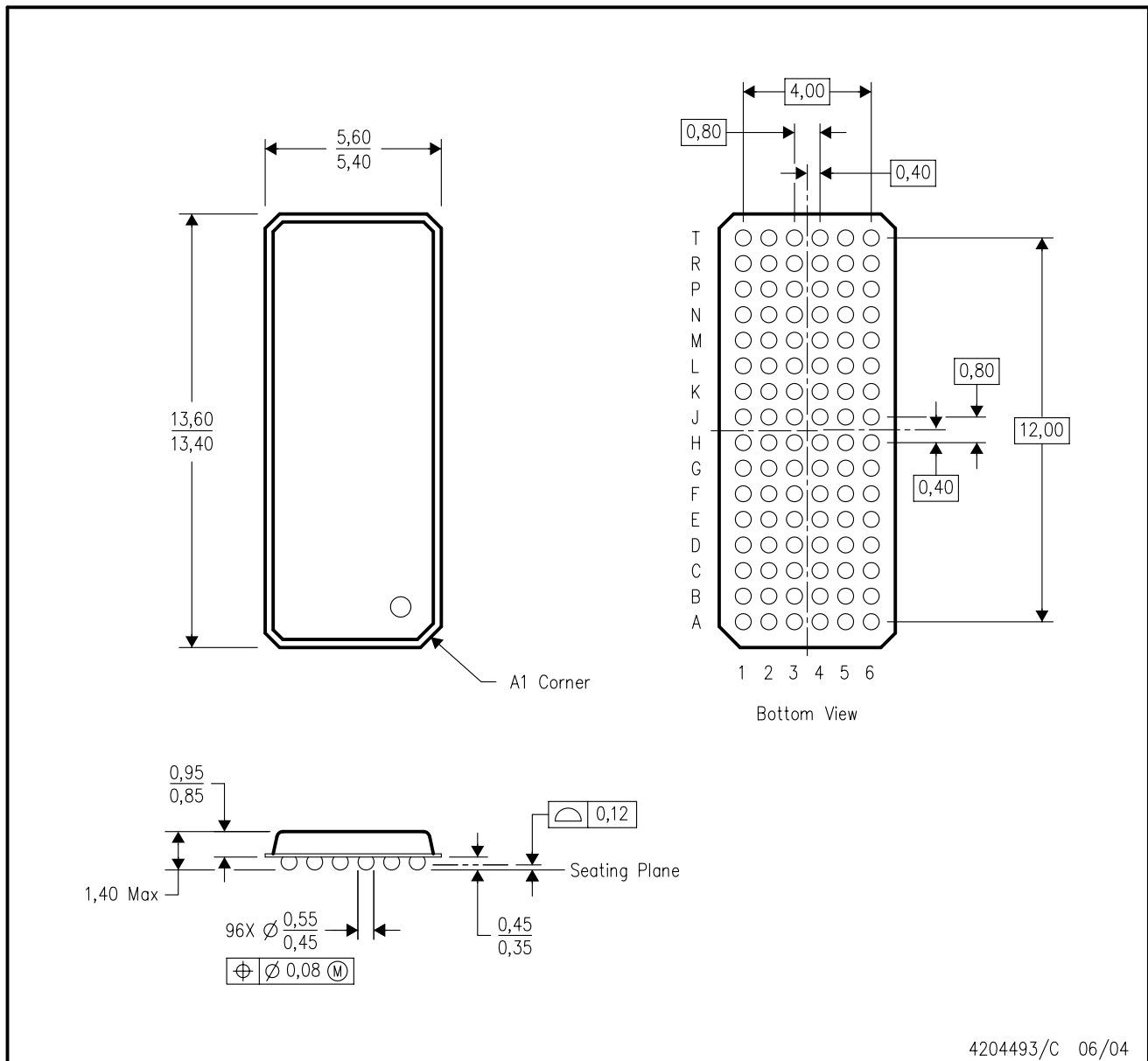

- NOTES:
- A. All linear dimensions are in millimeters.
  - B. This drawing is subject to change without notice.
  - C. Falls within JEDEC MO-205 variation CC.
  - D. This package is lead-free. Refer to the 96 GKE package (drawing 4188953) for tin-lead (SnPb).

## IMPORTANT NOTICE

Texas Instruments Incorporated and its subsidiaries (TI) reserve the right to make corrections, enhancements, improvements and other changes to its semiconductor products and services per JESD46, latest issue, and to discontinue any product or service per JESD48, latest issue. Buyers should obtain the latest relevant information before placing orders and should verify that such information is current and complete. All semiconductor products (also referred to herein as "components") are sold subject to TI's terms and conditions of sale supplied at the time of order acknowledgment.

TI warrants performance of its components to the specifications applicable at the time of sale, in accordance with the warranty in TI's terms and conditions of sale of semiconductor products. Testing and other quality control techniques are used to the extent TI deems necessary to support this warranty. Except where mandated by applicable law, testing of all parameters of each component is not necessarily performed.

TI assumes no liability for applications assistance or the design of Buyers' products. Buyers are responsible for their products and applications using TI components. To minimize the risks associated with Buyers' products and applications, Buyers should provide adequate design and operating safeguards.

TI does not warrant or represent that any license, either express or implied, is granted under any patent right, copyright, mask work right, or other intellectual property right relating to any combination, machine, or process in which TI components or services are used. Information published by TI regarding third-party products or services does not constitute a license to use such products or services or a warranty or endorsement thereof. Use of such information may require a license from a third party under the patents or other intellectual property of the third party, or a license from TI under the patents or other intellectual property of TI.

Reproduction of significant portions of TI information in TI data books or data sheets is permissible only if reproduction is without alteration and is accompanied by all associated warranties, conditions, limitations, and notices. TI is not responsible or liable for such altered documentation. Information of third parties may be subject to additional restrictions.

Resale of TI components or services with statements different from or beyond the parameters stated by TI for that component or service voids all express and any implied warranties for the associated TI component or service and is an unfair and deceptive business practice. TI is not responsible or liable for any such statements.

Buyer acknowledges and agrees that it is solely responsible for compliance with all legal, regulatory and safety-related requirements concerning its products, and any use of TI components in its applications, notwithstanding any applications-related information or support that may be provided by TI. Buyer represents and agrees that it has all the necessary expertise to create and implement safeguards which anticipate dangerous consequences of failures, monitor failures and their consequences, lessen the likelihood of failures that might cause harm and take appropriate remedial actions. Buyer will fully indemnify TI and its representatives against any damages arising out of the use of any TI components in safety-critical applications.

In some cases, TI components may be promoted specifically to facilitate safety-related applications. With such components, TI's goal is to help enable customers to design and create their own end-product solutions that meet applicable functional safety standards and requirements. Nonetheless, such components are subject to these terms.

No TI components are authorized for use in FDA Class III (or similar life-critical medical equipment) unless authorized officers of the parties have executed a special agreement specifically governing such use.

Only those TI components which TI has specifically designated as military grade or "enhanced plastic" are designed and intended for use in military/aerospace applications or environments. Buyer acknowledges and agrees that any military or aerospace use of TI components which have **not** been so designated is solely at the Buyer's risk, and that Buyer is solely responsible for compliance with all legal and regulatory requirements in connection with such use.

TI has specifically designated certain components as meeting ISO/TS16949 requirements, mainly for automotive use. In any case of use of non-designated products, TI will not be responsible for any failure to meet ISO/TS16949.

### Products

Audio	<a href="http://www.ti.com/audio">www.ti.com/audio</a>
Amplifiers	<a href="http://amplifier.ti.com">amplifier.ti.com</a>
Data Converters	<a href="http://dataconverter.ti.com">dataconverter.ti.com</a>
DLP® Products	<a href="http://www.dlp.com">www.dlp.com</a>
DSP	<a href="http://dsp.ti.com">dsp.ti.com</a>
Clocks and Timers	<a href="http://www.ti.com/clocks">www.ti.com/clocks</a>
Interface	<a href="http://interface.ti.com">interface.ti.com</a>
Logic	<a href="http://logic.ti.com">logic.ti.com</a>
Power Mgmt	<a href="http://power.ti.com">power.ti.com</a>
Microcontrollers	<a href="http://microcontroller.ti.com">microcontroller.ti.com</a>
RFID	<a href="http://www.ti-rfid.com">www.ti-rfid.com</a>
OMAP Applications Processors	<a href="http://www.ti.com/omap">www.ti.com/omap</a>
Wireless Connectivity	<a href="http://www.ti.com/wirelessconnectivity">www.ti.com/wirelessconnectivity</a>

### Applications

Automotive and Transportation	<a href="http://www.ti.com/automotive">www.ti.com/automotive</a>
Communications and Telecom	<a href="http://www.ti.com/communications">www.ti.com/communications</a>
Computers and Peripherals	<a href="http://www.ti.com/computers">www.ti.com/computers</a>
Consumer Electronics	<a href="http://www.ti.com/consumer-apps">www.ti.com/consumer-apps</a>
Energy and Lighting	<a href="http://www.ti.com/energy">www.ti.com/energy</a>
Industrial	<a href="http://www.ti.com/industrial">www.ti.com/industrial</a>
Medical	<a href="http://www.ti.com/medical">www.ti.com/medical</a>
Security	<a href="http://www.ti.com/security">www.ti.com/security</a>
Space, Avionics and Defense	<a href="http://www.ti.com/space-avionics-defense">www.ti.com/space-avionics-defense</a>
Video and Imaging	<a href="http://www.ti.com/video">www.ti.com/video</a>

### TI E2E Community

[e2e.ti.com](http://e2e.ti.com)