

SANYO

No. 4345A

STK6105**DC 3-phase Brushless Motor Driver
(Output Current 5A)****Overview**

The STK6105 is a hybrid IC incorporating a 3-phase brushless motor controller and driver into a single package, on the Sanyo IMST (Insulated Metal Substrate Technology) substrate. Revolution speed is controlled through the DC voltage level (V_{ref1}) external input and PWM control of motor phase winding current. The driver is MOSFET to minimize circuit loss and handle high-output current (rush current) demands.

Applications

- PPC and LBP drum motors
- Air conditioner fan motors

Features

- The output driver transistor is MOSFET for low power loss (half that of a bipolar transistor) and reliable handling of high-output current (rush current).
- Variation in V_{ref1} level causes the driver transistor to switch to PWM drive for high-efficiency motor speed variation.
- Normal and reverse revolution select function.
- Start/stop and brake functions.
- Current limiter function.

Specifications**Maximum Ratings at $T_a=25^\circ\text{C}$**

				Unit
Maximum supply voltage 1	V_{CC1} max	No input signal	50	V
Maximum supply voltage 2	V_{CC2} max	No input signal	7	V
Maximum output current	I_o max	Position detect input signal cycle = 30 ms, PWM duty = 50%, operation time 1s	8	A
Operating substrate temperature	T_c max		105	$^\circ\text{C}$
Junction temperature	T_j max		150	$^\circ\text{C}$
Storage temperature	T_{stg}		-40 to +125	$^\circ\text{C}$

Allowable Operating Ranges at $T_a=25^\circ\text{C}$

				unit
Supply voltage 1	V_{CC1}	With input signal	16 to 42	V
Output current	I_o ave	DC phases present	5	A
Supply voltage 2	V_{CC2}	With input signal	4.75 to 6.00	V
Brake current	I_{OB}	80 Hz full sine waves (all phases). Operating time 0.1 s, duty = 5% (see Note 1).	11	A

Package Dimensions

unit: mm

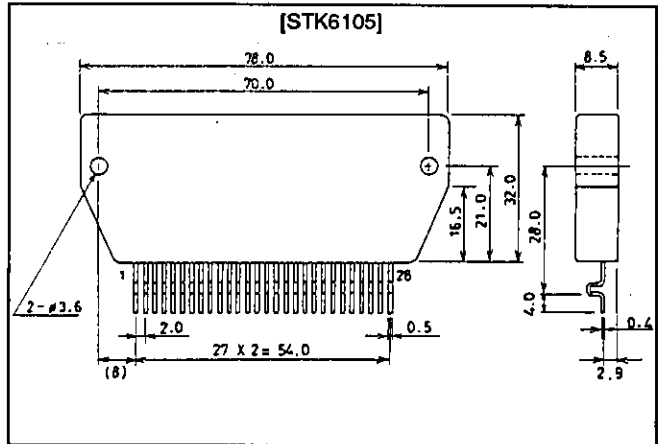
4130

STK6105

Electrical Characteristics at $T_c=25^\circ\text{C}$, $V_{CC1} = 24\text{V}$, $V_{CC2} = 5.0\text{V}$

			min	typ	max	Unit
Supply current 1 (pin 13)	I_{CCO1}	CW revolution		12	20	mA
Supply current 2 (pin 13)	I_{CCO2}	Braking		26	38	mA
Output saturation voltage 1	V_{st1}	V_{CC1} side TR, $I_o = 5\text{A}$		0.70	0.91	V
Output saturation voltage 2	V_{st2}	GND side TR, $I_o = 5\text{A}$		0.85	1.11	V
Internal MOSFET diode forward voltage	V_F	$I_F = 5\text{A}$		1.0	1.5	V
PWM oscillation frequency	f_C		20	25	30	kHz
Current limiter reference voltage	V_{ref2}		0.78	0.83	0.88	V
Position detect input sensitivity	V_H		20		500	mV
Position detect common mode range	CMRH		2.0		4.5	V
Input "L" current 1 (pins 2,3)	I_{IL1}	$V_{IL1} = \text{GND}$		130	200	μA
Input "L" voltage 1 (pins 2,3)	V_{IL1}				1.0	V
Input "L" current 2 (pin 4)	I_{IL2}	$V_{IL2} = \text{GND}$		570	910	μA
Input "L" voltage 2 (pin 4)	V_{IL2}				1.0	V
V_{ref1} "H" voltage	V_{ref1H}	GND side transistor not in PWM		2.82	3.20	V
V_{ref1} "L" voltage	V_{ref1L}	GND side transistor off	0.15	0.35		V
Zener voltage	V_Z		5.7	6.2	6.7	V
FG output current	I_{FGH}	$V_{FG} = 1.6\text{V}$	80			μA
FG output "L" voltage	V_{FGL}	$I_{FG} = 0.3\text{mA}$			0.4	V
FG output pulse width	τ_{FG}	$C_P = 0.1\mu\text{F}$, $R_P = 10\text{k}\Omega$	0.9	1.0	1.1	ms

Equivalent Circuit

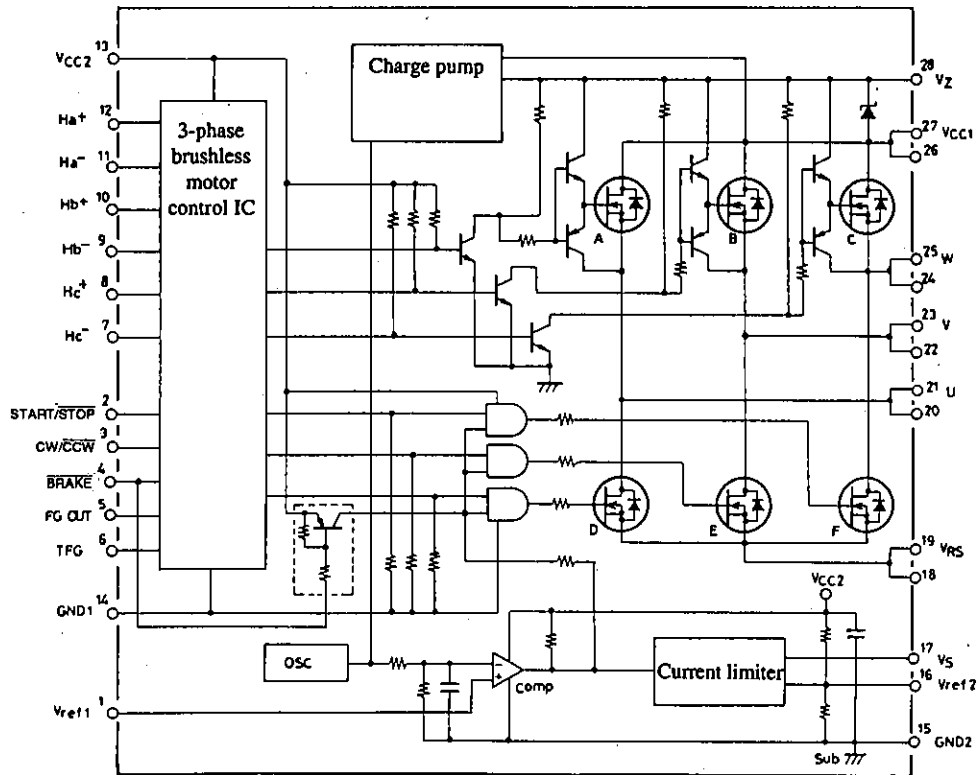

Pin Functions

Pin No.	Symbol	Function
1	Vref ₁	GND-side driver transistor PWM control pin; range 0.15 to 3.2V
2	START/STOP	"H" = start, "L" = stop (all transistors off)
3	CW/CCW	"H" = CW, "L" = CCW
4	BRAKE	"H" = rotate, "L" = Only GND-side transistor on
5	FG OUT	Position detect signal: output 6 pulses per cycle
6	TFG	For setting FG OUT "L" level pulse width. R _F and C _F pins.
7	H _{C-}	Motor position detect signal input pin (to Hall device)
8	H _{C+}	Motor position detect signal input pin (to Hall device)
9	H _{b-}	Motor position detect signal input pin (to Hall device)
10	H _{b+}	Motor position detect signal input pin (to Hall device)
11	H _{a-}	Motor position detect signal input pin (to Hall device)
12	H _{a+}	Motor position detect signal input pin (to Hall device)
13	V _{CC2}	Motor controller supply voltage pin
14	GND1	Motor controller IC GND pin; signal gnd (SG)
15	GND2	External R _S GND-side connection pin; power gnd (PG)
16	Vref ₂	Current limiter set pin; 0.167V _{CC2} when open.
17	V _S	External R _S current limiter detect pin
18, 19	V _{RS}	External R _S connect pin
20, 21	U	Output pin (to motor winding)
22, 23	V	Output pin (to motor winding)
24, 25	W	Output pin (to motor winding)
26, 27	V _{CC1}	Supply voltage pin (to motor)
28	V _Z	Zener voltage (6.2V typ) for V _{CC1} driver transistor base source supply

Input Type

Input pin No.	Type
② ③	
④	

Note 1: I_{OB} indicates the operating current waveform peak as shown below.

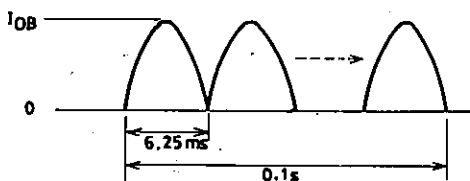

Sample Application Circuit

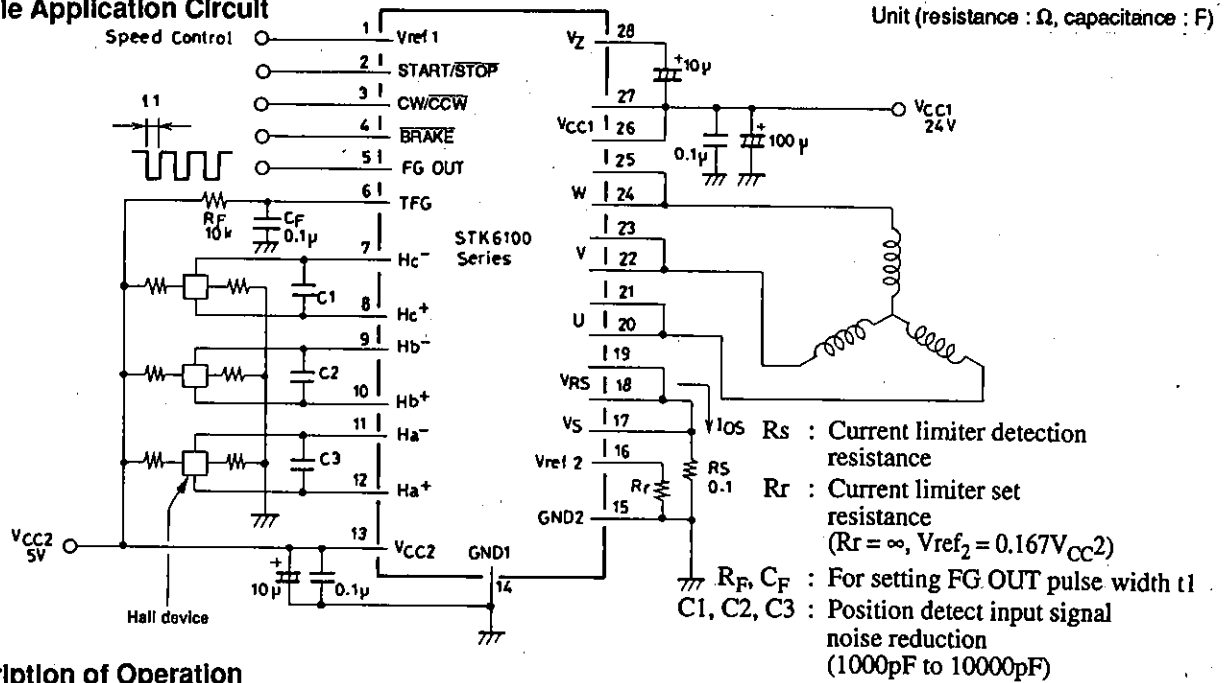

Description of Operation

The DC 3-phase brushless motor generally uses a permanent magnet for the rotor and places the stator coil around it. When the rotor and stator coil are excited, magnetic force is generated between the poles, which is used for revolution torque. For efficient revolution it is necessary to know precisely where the rotor pole is in relation to the stator pole. In the brushless motor Hall devices and Hall ICs are widely used for this purpose, by detecting the electric power generated along the lines of magnetic force.

(1) Motor rotating force

The block diagram for this HIC is given in Fig. 2.

The conditions before input of VCC1, with VCC2 on, are START/STOP pin H level, CW/CCW pin H level, BRAKE pin H level and Vref1 pin (speed control input) H level. The position detect signal at this time, due to the effect of the rotor magnetic field, will be output signals from 1 or 2 devices (of the 3) so that Hx+ > Hx- is input to HIC pins 7-12. The signals input to pins 7-12 are input to the motor controller and converted into signals compatible with 3-phase brushless motor revolution. When VCC1 is supplied the charge pump circuit activates, generating VCC1 MOSFET gate voltage VZ. This outputs excitation current to the motor phase windings as indicated in the timing chart (Fig. 3), and rotating the motor.

For revolution speed control, the Vref1 pin voltage is converted and used for PWM drive to increase GND transistor efficiency, controlling the conduction of motor current Io (Fig. 1). Control of Io means control of power supplied to the motor, which controls motor rpm. In general motor rpm N is proportional to the PWM on duty (when motor load is constant). The PWM on duty is proportional to the size of Vref1 (see Fig. 13), and the relation of N is as outlined below.

$$N \propto \text{PWM ON Duty} \propto V_{ref1}$$

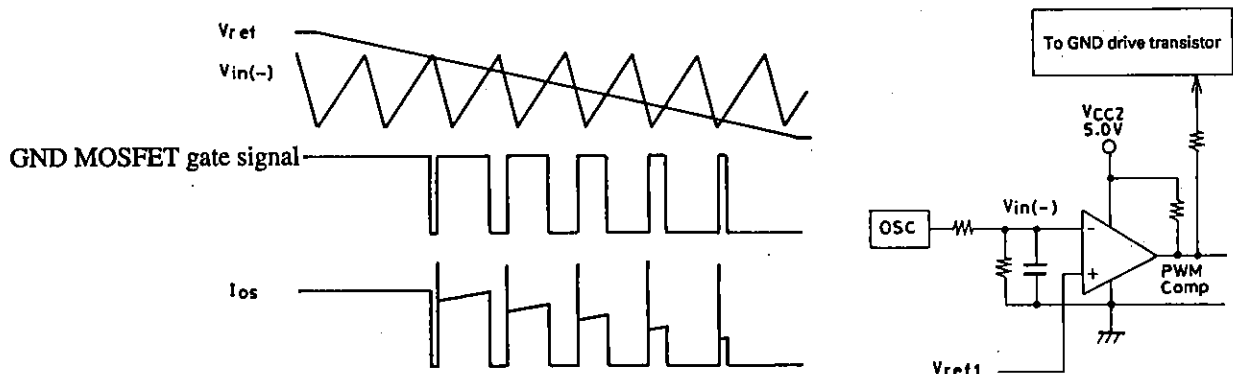

Fig.1 PWM Drive Principle

Motor revolution is stopped by setting START/STOP to L level to turn off all drive transistors, and cut the supply of current to the motor. Motor inertia will prevent instantaneous stopping. The brake function works to shorten the amount of time needed to come to a complete stop. In input level L the V_{CC1} driver transistor is turned off, all GND driver transistors are turned on, and the amount of power generated by the rotating motor windings reduced to reduce the rpms. This brake function has priority over all START/STOP, CW/CCW and position detect input conditions.

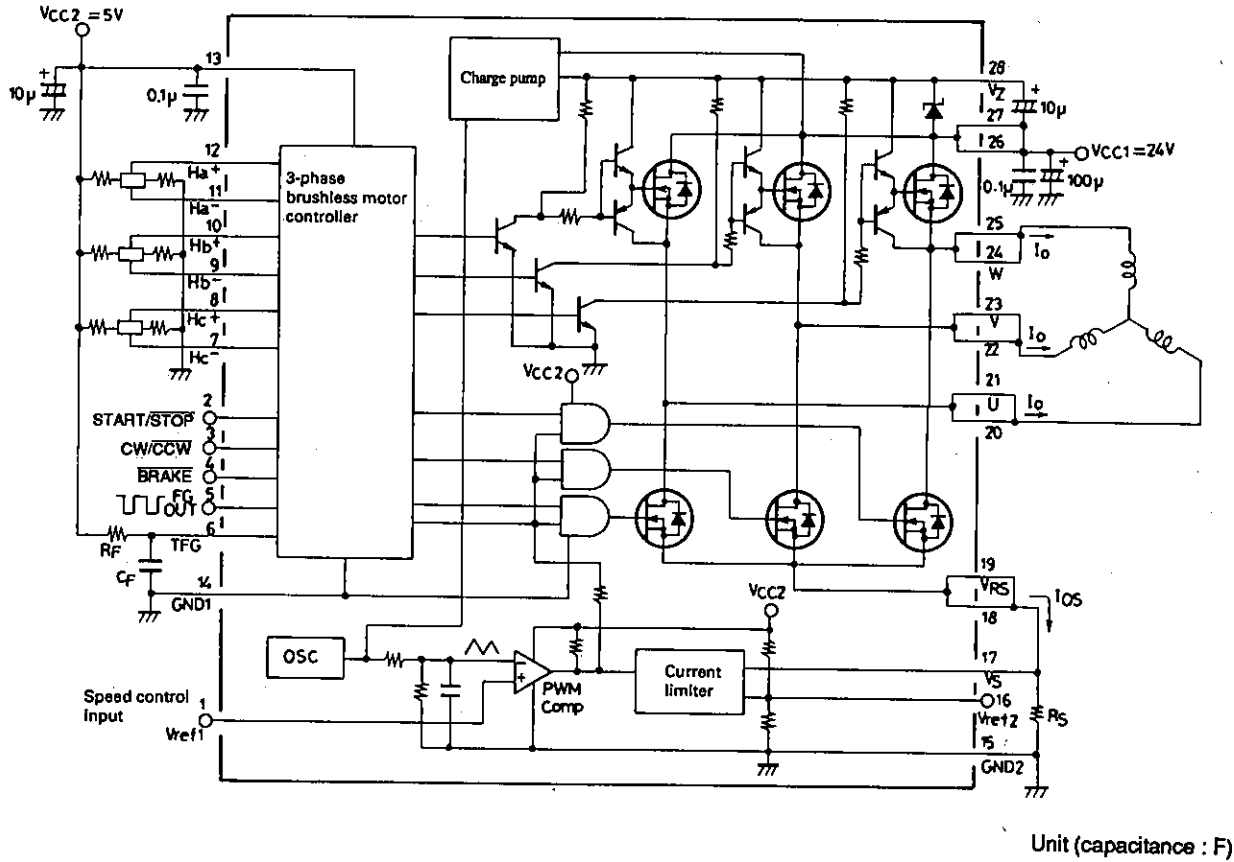

Fig. 2 Block Diagram

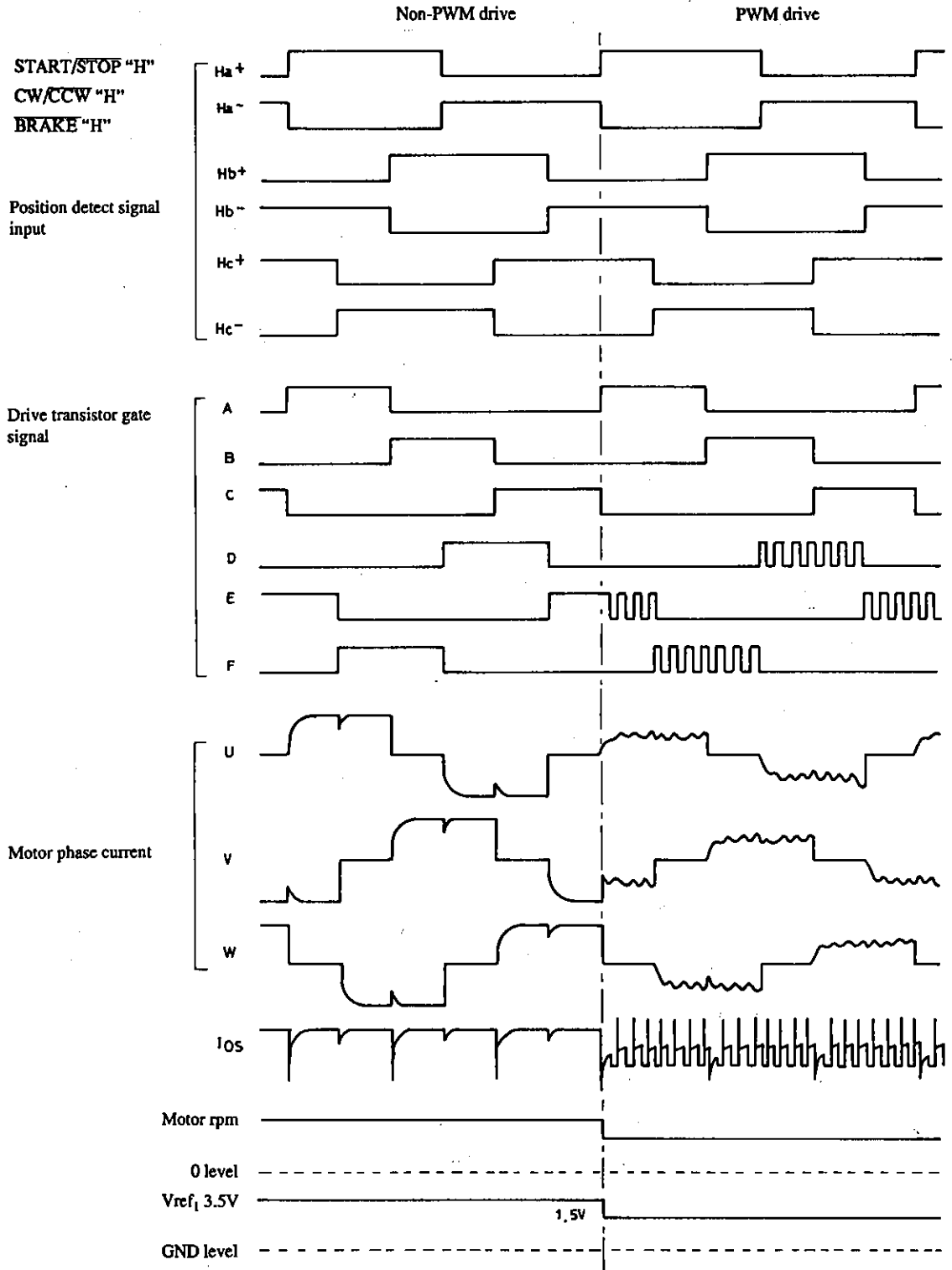

Fig. 3 I/O Timing Chart

(2) Other functions

① CW/CCW

The direction of motor revolution can be selected by setting the input level to H or L. CW is H level and CCW is L level. The CW timing chart is indicated in Fig. 3, and the CCW timing chart in Fig. 5.

② Current limiter function

The current limiter converts the GND driver transistor source current into V_{RS} through the external R_S , and controls GND driver transistor conduction based on a comparison of this voltage to V_{ref2} . V_{ref2} generates a $0.167V_{CC2}$ voltage in pin open state. V_{ref2} is generated by the voltage division between $15\text{ k}\Omega$ and $3\text{ k}\Omega$ resistances, and so the V_{ref2} level can be readily reduced by attaching an external resistor. To prevent HIC destruction in the event of motor lock, a current limiter can be enabled by setting V_{ref2} at or below I_o ave. If no such protection is required, set V_{ref2} between I_o max and I_o ave to limit rush current.

③ FG OUT

This pin outputs a square wave pulse proportional to one motor revolution, which can be used as the motor servo-control PLL IC FG input signal. The square wave L level time t_1 is set by the time constant of C_F and R_F connected to the TFG pin (Fig. 4).

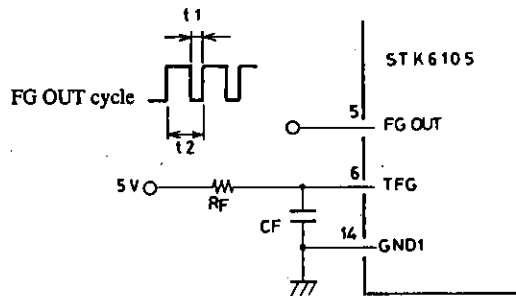

Fig.4

In general, when the n-pole 3-phase brushless motor fixed-speed rpm is expressed as $N(\text{rpm})$, the setting for t_1 so that $t_1 = 0.5 t_2$ is given by expression ①.

$$t_1 = \frac{1000}{\frac{N}{60} \times 6 \times \frac{n}{2}} \times 0.5 \quad [\text{ms}] \dots\dots\dots \text{①}$$

The relation between C_F , R_F and t_1 is given by expression ②.

$$t_1 = a \cdot R_F \cdot C_F \dots\dots\dots \text{②}$$

$$\text{However, } a = 1 \left(\frac{\text{s}}{\Omega \cdot \text{F}} \right), R_F = 3\text{ k}\Omega \text{ to } 30\text{ k}\Omega, t_1 > 50\ \mu\text{s}$$

Expression ① is designed to be half that of fixed speed t_2 , but when an FV conversion circuit is connected to the FG OUT pin, it is necessary to reduce the duty to under 50%. In this case, adjust R_F or C_F as needed.

(3) Precautions in drive

① Start current (rush current)

The motor start R_s current waveform is shown in Fig. 6. Current peak I_{OH} must not exceed I_o max.

② Position detect signal

Because signal input sensitivity V_H is $\pm 500\text{ mV}$ max, the level of the output signal (open collector) from the Hall IC must be reduced through conversion. A sample of this circuit is shown in Fig. 7. The position detect signal must be compatible with the motor phase winding even in the time chart state shown in Fig. 3, or the motor may not revolve smoothly.

③ Motor phase winding current during braking

The motor phase winding current during braking must not exceed I_o max even during peak, although several times set current levels are input.

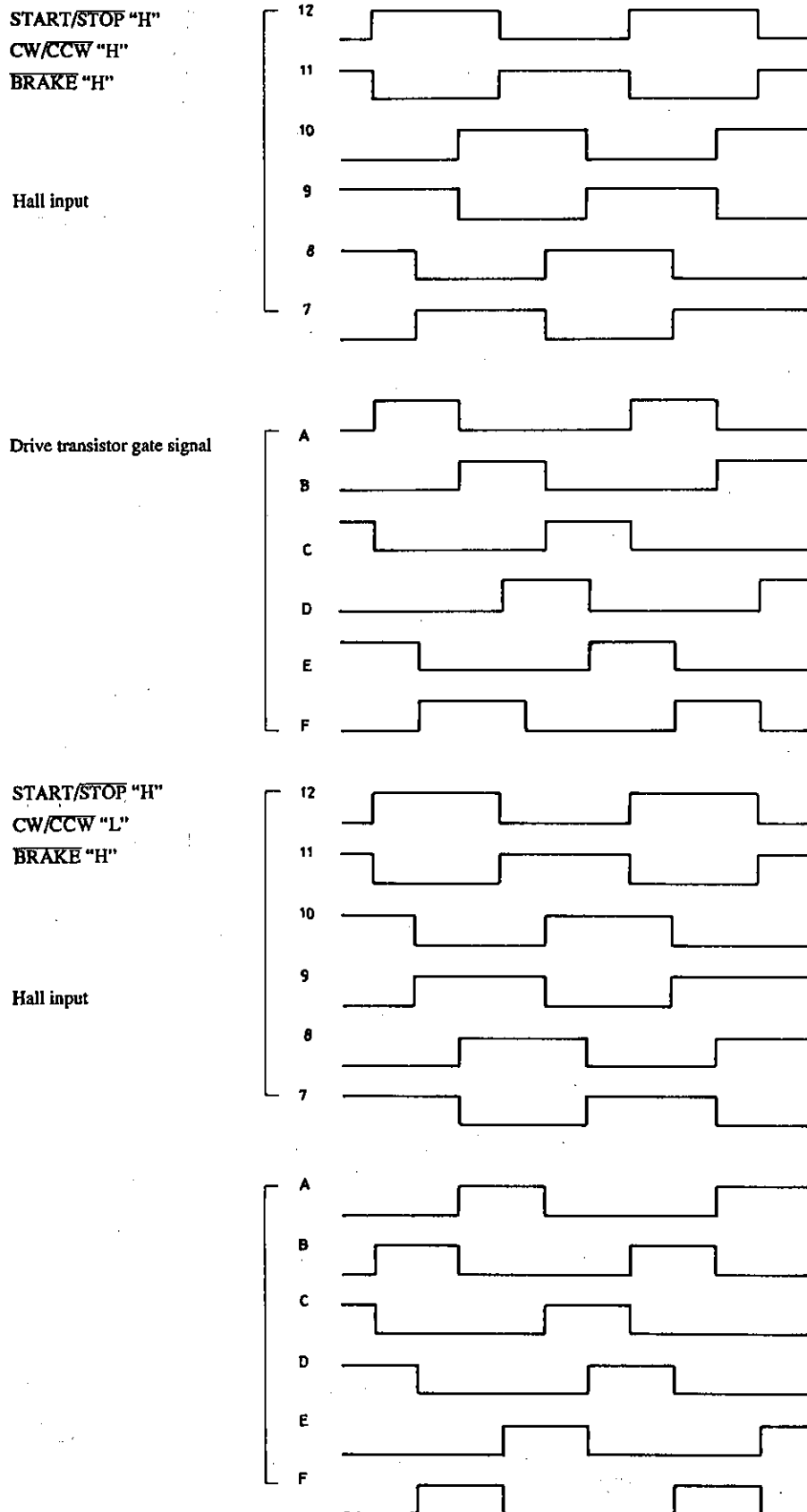

Fig. 5 CW/CCW I/O Timing Chart



Fig.6 Starting Current

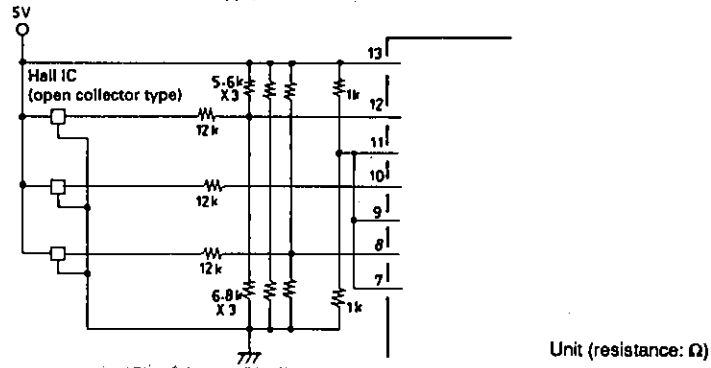

Fig.7 Conversion Circuit for Hall IC and Hall Device Signal

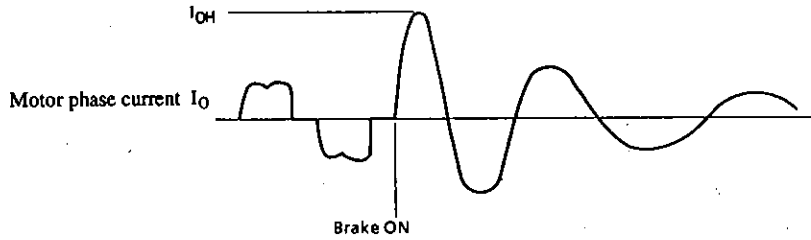

Fig.8

Thermal Radiation Design

(1) Internal average power dissipation Pd

The driver transistors represent the majority of the power dissipation in operation. Other losses are V_{CC2} and the charge pump circuit. In PWM drive in particular, the diode in the V_{CC1} transistor is being used as a flywheel diode, increasing V_{CC1} transistor loss. When these are included, internal mean power dissipation is:

$$Pd = I_o (V_{st1} + V_F d_2 + V_{st2} d_1) + Pd_A + Pd_B + Pd_C \dots\dots\dots \textcircled{1}$$

- I_o : Motor current
- V_{st1} : V_{CC1} transistor saturation voltage
- V_{st2} : GND transistor saturation voltage
- d₁ : GND transistor PWM operation on duty
- d₂ : GND transistor PWM operation off duty
- Pd_A : V_{CC2} loss
- Pd_B : Charge pump circuit loss
- Pd_C : GND transistor switching loss
- V_F : V_{CC1} transistor internal diode normal direction voltage

Because the driver transistor is a MOSFET, V_{st1} and V_{st2} will increase with an increase in I_O or substrate temperature T_c.

Pd_A and Pd_B are generally given as:

$$Pd_A \approx V_{CC2} \times I_{CCO1} \dots\dots\dots \textcircled{2}$$

$$Pd_B \approx V_{CC1} \times (0.49V_{CC1} - 4.2) \times 0.001 \dots\dots\dots \textcircled{3}$$

where, V_{CC1} = 16 to 42V

Refer to Figs. 11-14 for data on V_{st1}, V_{st2}, d₁ and V_F.

(2) Thermal radiation design

Actual thermal radiation design requires determination of the IC internal average power Pd from the motor phase current Io (Fig. 9). Pd is then used to determine the thermal resistance for the radiator from the following expression.

$$\theta_{c-a} = \frac{T_{c \max} - T_a}{P_d} \text{ (}^\circ\text{C/W)}$$

where $T_{c \max} = 105^\circ\text{C}$
 $T_a = \text{ambient temperature}$

With a 2.00 mm radiation plate, the required area can be determined from Fig. 10. Note that substrate temperature will vary widely with set internal air temperature, and Tc for the mounted state must be 105°C max.

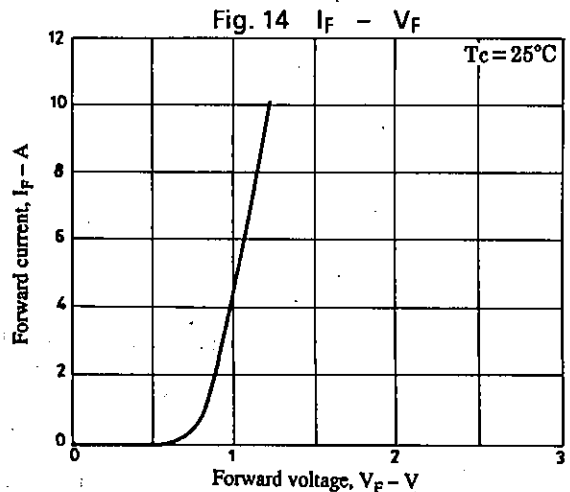
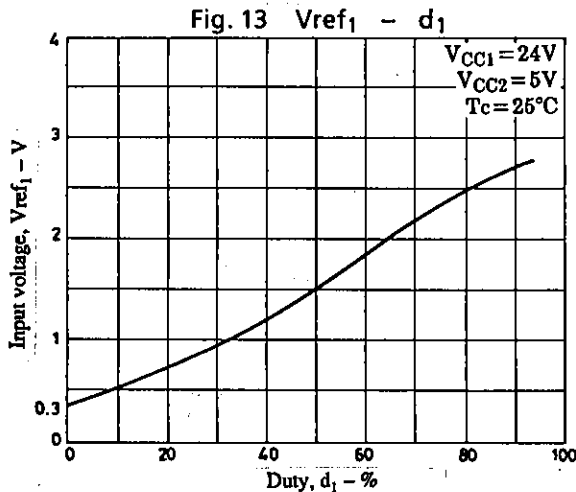
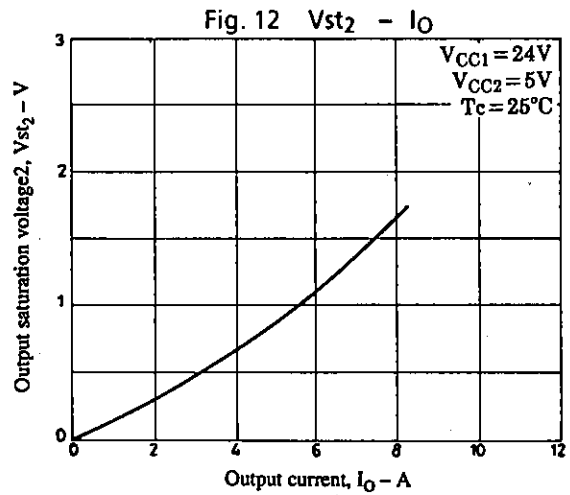
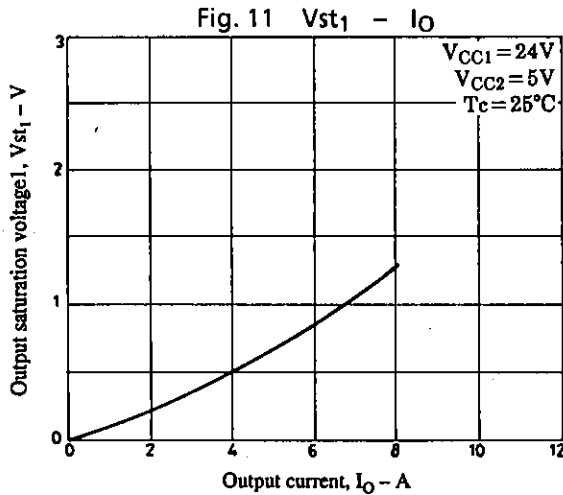
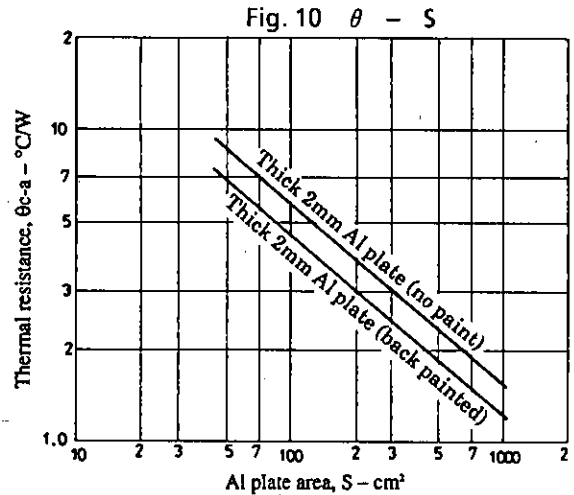
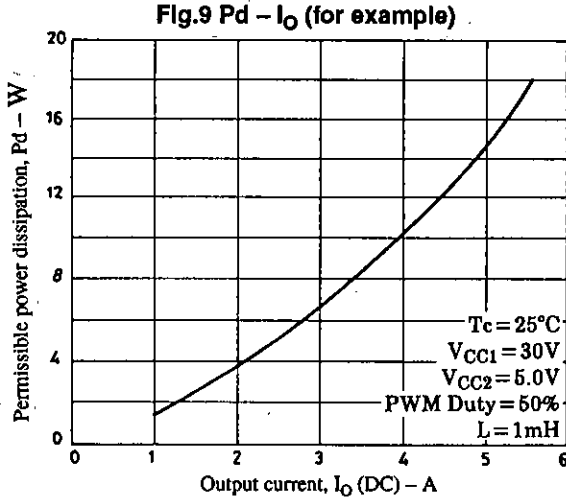

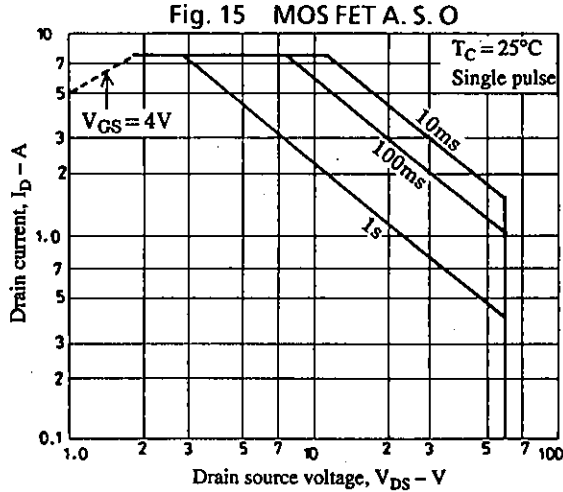

- No products described or contained herein are intended for use in surgical implants, life-support systems, aerospace equipment, nuclear power control systems, vehicles, disaster/crime-prevention equipment and the like, the failure of which may directly or indirectly cause injury, death or property loss.
- Anyone purchasing any products described or contained herein for an above-mentioned use shall:
 - ① Accept full responsibility and indemnify and defend SANYO ELECTRIC CO., LTD., its affiliates, subsidiaries and distributors and all their officers and employees, jointly and severally, against any and all claims and litigation and all damages, cost and expenses associated with such use:
 - ② Not impose any responsibility for any fault or negligence which may be cited in any such claim or litigation on SANYO ELECTRIC CO., LTD., its affiliates, subsidiaries and distributors or any of their officers and employees jointly or severally.
- Information (including circuit diagrams and circuit parameters) herein is for example only; it is not guaranteed for volume production. SANYO believes information herein is accurate and reliable, but no guarantees are made or implied regarding its use or any infringements of intellectual property rights or other rights of third parties.

This catalog provide information as of May, 1995. Specifications and information herein are subject to change without notice.