

DC to VHF WIDEBAND DIFFERENTIAL INPUT AND OUTPUT AMPLIFIER IC

DESCRIPTION

The μPC1663 is a differential input, differential output wideband amplifier IC that uses an high frequency silicon bipolar process. This process improves bandwidth phase characteristics, input noise voltage characteristics, and low power consumption when compared to conventional HF-band differential amplifier ICs.

These features make this device suitable as a wideband amplifier in high-definition TVs, high-resolution monitors, broadcasting satellite receivers, and video cameras, as a sense amplifier in high-density CCD and optical pick-up products, or as a pulse amplifier for optical data links.

These ICs are manufactured using NEC's 6 GHz fr NESAT™ I silicon bipolar process. This process uses silicon nitride passivation film and gold electrodes. These materials can protect chip surface from external pollution and prevent corrosion/migration. Thus, these ICs have excellent performance, uniformity and reliability.

FEATURES

- Bandwidth and typical gain: 120 MHz @ $A_{VOL} = 300$
700 MHz @ $A_{VOL} = 10$
- Phase delay : -85 deg. @ $A_{VOL} = 100$, 100 MHz
- Input Noise Voltage : $3 \mu V_{r.m.s.}$ ($R_s = 50 \Omega$, 10 k to 10 MHz)
- Supply Current : 13mA TYP. @ $V_{CC}^{\pm} = \pm 6 V$
- Gain adjustable from 10 to 300 with external resistor
- No frequency compensation required (Small phase delay at 10 MHz or less)

ORDERING INFORMATION

Part Number	Package	Marking	Supplying Form
μPC1663G-E1	8-pin plastic SOP (225 mil)	1663	Embossed tape 12 mm wide. Pin 1 is in tape pull-out direction. Qty 2.5 kp/reel.
μPC1663GV-E1	8-pin plastic SSOP (175 mil)		Embossed tape 8 mm wide. Pin 1 is in tape pull-out direction. Qty 1 kp/reel.

Remark To order evaluation samples, please contact your local NEC sales office. (Part number for sample order: μPC1663G, μPC1663GV)

Caution μPC1663C (8-pin plastic DIP) is discontinued.

Caution Electro-static sensitive devices

The information in this document is subject to change without notice. Before using this document, please confirm that this is the latest version.
Not all devices/types available in every country. Please check with local NEC representative for availability and additional information.

CONNECTION DIAGRAM

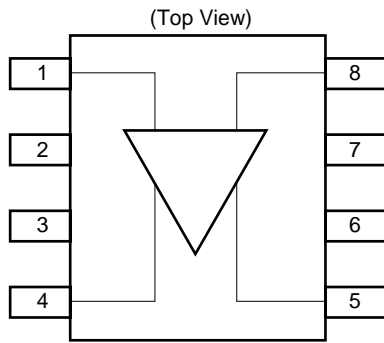

Pin No.	Pin Name
1	IN ₂
2	G _{1B}
3	V _{CC} ⁻
4	OUT ₂
5	OUT ₁
6	V _{CC} ⁺
7	G _{1A}
8	IN ₁

PIN EXPLANATIONS

Pin No.	Pin Name	In Dual Bias (V)	In Single Bias (V)	Functions and Applications	Internal Equivalent Circuit
8 1	IN ₁ IN ₂	Pin voltage 0	Apply voltage V _{CC} /2	Input pin	<p>Internal circuit constants should be referred to application note.</p>
5 4	OUT ₁ OUT ₂	Pin voltage 0	Apply voltage V _{CC} /2	Output pin	
6	V _{CC} ⁺	±2 to ±6.5	-0.3 to +14	Plus voltage supply pin. This pin should be connected with bypass capacitor to minimize AC impedance.	
3	V _{CC} ⁻		GND	Minus voltage supply pin. This pin should be connected with bypass capacitor to minimize AC impedance.	
7 2	G _{1A} G _{1B}	—	—	Gain adjustment pin. External resistor from 0 to 10 kΩ can be inserted between pin 2 and 7 to determine gain value.	

Note μPC1664 which had G_{2A}, G_{2B} of the other gain adjustment pins is discontinued.

ABSOLUTE MAXIMUM RATINGS (T_A = +25 °C)

Parameter	Symbol	μPC1663G	μPC1663GV	Unit
Supply Voltage	V _{CC±}	±7	±7	V
Power Dissipation	P _D	280 (T _A = +75°C) ^{Note}	280 (T _A = +75 °C) ^{Note}	mW
Differential Input Voltage	V _{ID}	±5	±5	V
Input Voltage	V _{ICM}	±6 (within V _{CC-} to V _{CC+} range)	±6 (within V _{CC-} to V _{CC+} range)	V
Output Current	I _O	35	35	mA
Operating Ambient Temperature	T _A	-45 to +75	-45 to +75	°C
Storage Temperature	T _{stg}	-55 to +150	-55 to +150	°C

Note Mounted on double sided copper clad 50 × 50 × 1.6 mm epoxy glass PWB

RECOMMENDED OPERATING CONDITIONS

Parameter	Symbol	MIN.	TYP.	MAX.	Unit
Supply Voltage	V _{CC±}	±2	±6	±6.5	V
Output Source Current	I _{O source}	—	—	20	mA
Output Sink Current	I _{O sink}	—	—	2.5	mA
Operating Frequency Range	f _{opt}	DC	—	200	MHz

ELECTRICAL CHARACTERISTICS (T_A = +25 °C, V_{CC}[±] = ±6 V)

Parameter		Symbol	Conditions	MIN.	TYP.	MAX.	Unit
Differential Voltage Gain	Gain 1	A _{vd}	f = 10 MHz ^{Note 1}	200	320	500	—
	Gain 2		f = 10 MHz ^{Note 2}	8	10	12	
Bandwidth	Gain 1	BW	R _S = 50 Ω (3 dB down point)	—	120	—	MHz
	Gain 2			—	700	—	
Rise Time	Gain 1	t _r	R _S = 50 Ω, V _{out} = 1 V _{P-P}	—	2.9	—	ns
	Gain 2			—	2.7	—	
Propagation Delay	Gain 1	t _{pd}	R _S = 50 Ω, V _{out} = 1 V _{P-P}	—	2	—	ns
	Gain 2			—	1.2	—	
Input Resistance	Gain 1	R _{in}		—	4.0	—	kΩ
	Gain 2			50	180	—	
Input Capacitance		C _{in}		—	2	—	pF
Input Offset Current		I _{io}		—	0.4	5.0	μA
Input Bias Current		I _B		—	20	40	μA
Input Noise Voltage		V _n	R _S = 50 Ω, 10 k to 10 MHz	—	3	—	μV _{r.m.s.}
Input Voltage Range		V _i		±1.0	—	—	V
Common Mode Rejection Ratio	Gain 2	CMR	V _{cm} = ±1 V, f ≤ 100 kHz	53	94	—	dB
Supply Voltage Rejection Ratio		SVR	ΔV = ±0.5 V	50	70	—	dB
Output Offset Voltage	Gain 1	V _{O(off)}	V _{O(off)} = OUT ₁ - OUT ₂	—	0.3	1.5	V
	Gain 2			—	0.1	1.0	
Output Common Mode Voltage		V _{O(CM)}		2.4	2.9	3.4	V
Output Voltage Swing		V _{OP-P}	Single-ended	3.0	4.0	—	V _{P-P}
Output Sink Current		I _{sink}		2.5	3.6	—	mA
Power Supply Current		I _{CC}		—	13	20	mA

- Notes**
- Gain select pins G_{1A} and G_{1B} are connected.
 - All gain select pins are opened.

TEST CIRCUIT

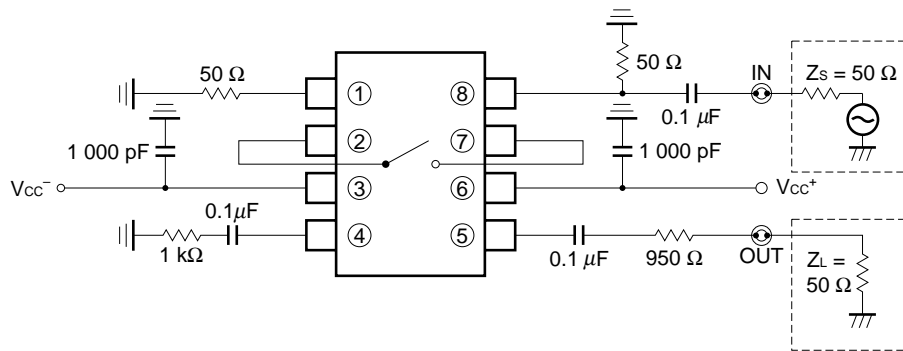

Remark Measurement value at OUT connector should be converted into DUT's output value at pin 5.

Remark Definition and test circuit of each characteristic should be referred to application note 'Usage of μPC1663 (Document No. G12290E)'.

NOTES ON CORRECT USE

- (1) Observe precautions for handling because of electro-static sensitive devices.
- (2) Form a ground pattern as wide as possible to minimize ground impedance (to prevent undesired oscillation).
- (3) The bypass capacitor should be attached to V_{cc} line.
- (4) When gain between Gain 1 and Gain 2 is necessary, insert adjustment resistor (0 to 10 kΩ) between G_{1A} and G_{1B} to determine gain value.
- (5) Due to high-frequency characteristics, the physical circuit layout is very critical. Supply voltage line bypass, double-sided printed-circuit board, and wide-area ground line layout are necessary for stable operation. Two signal resistors connected to both inputs and two load resistors connected to both outputs should be balanced for stable operation.

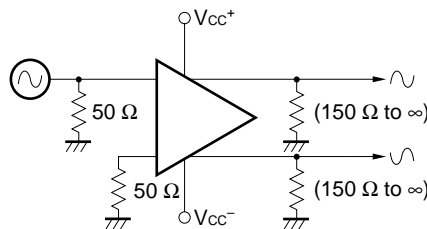

TYPICAL CHARACTERISTICS (Unless otherwise specified $T_A = +25\text{ }^\circ\text{C}$)

SINGLE-ENDED VOLTAGE GAIN vs. FREQUENCY

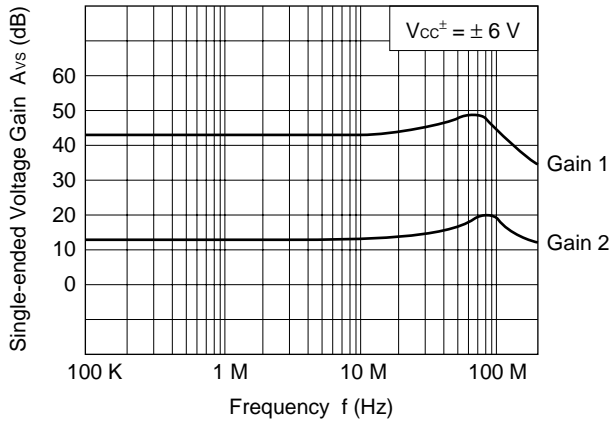

Remark Differential voltage gain is double of single-ended voltage gain.

RELATIVE VOLTAGE GAIN vs. OPERATING AMBIENT TEMPERATURE

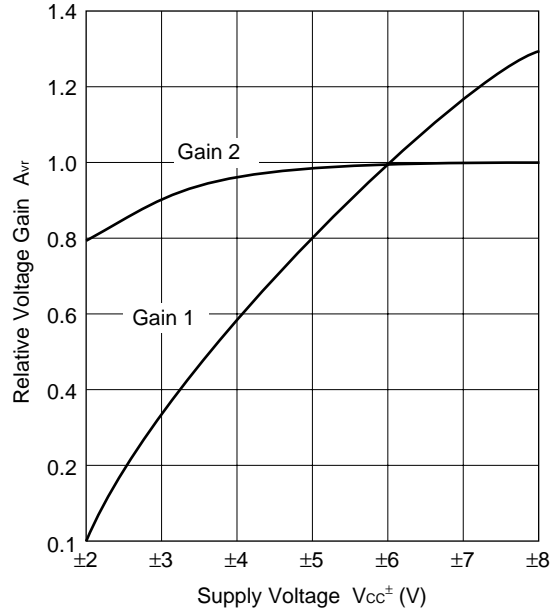

RELATIVE GAIN vs. OPERATING AMBIENT TEMPERATURE

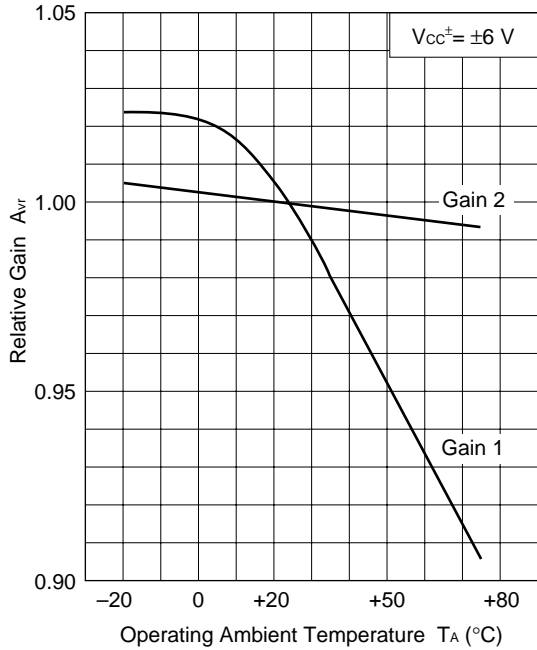

OUTPUT SINK CURRENT vs. OPERATING AMBIENT TEMPERATURE

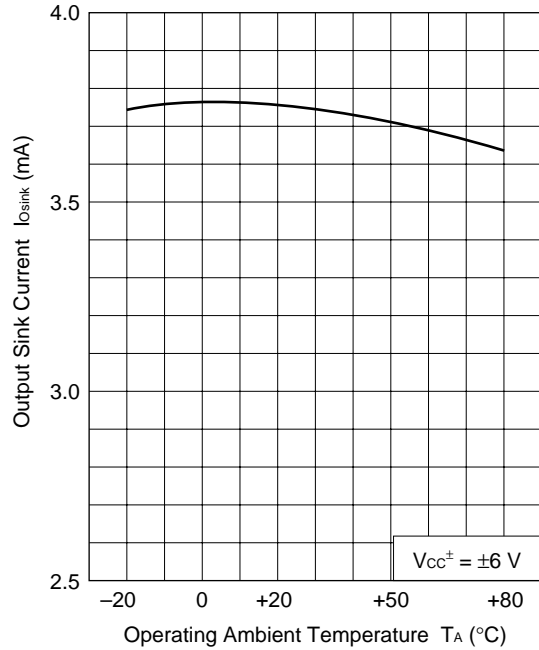

Remark Relative voltage gains are described based on gains 1.00 at $T_A = +25\text{ }^\circ\text{C}$, $V_{CC}^{\pm} = \pm 6\text{ V}$

SINGLE-ENDED OUTPUT VOLTAGE SWING vs. OPERATING AMBIENT TEMPERATURE

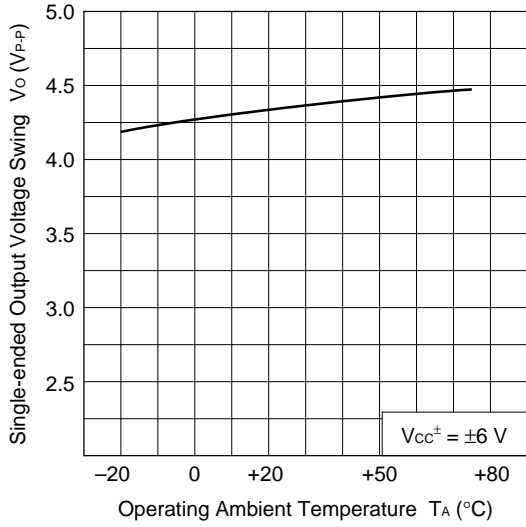

DIFFERENTIAL VOLTAGE GAIN vs. GAIN ADJUST RESISTANCE

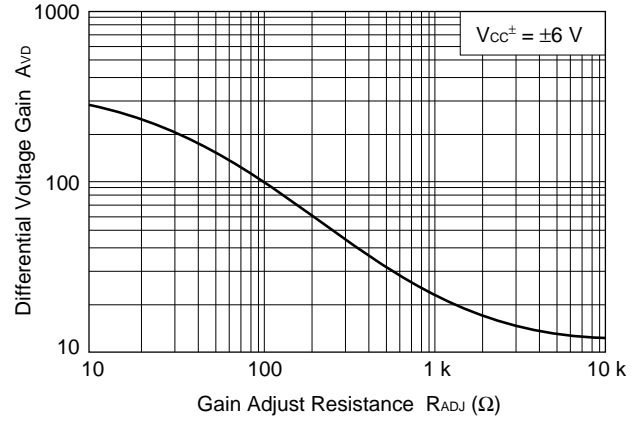

INPUT BIAS CURRENT vs. OPERATING AMBIENT TEMPERATURE

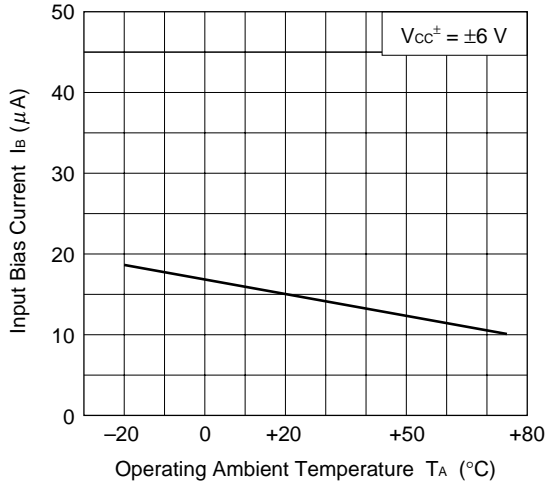

SUPPLY CURRENT vs. OPERATING AMBIENT TEMPERATURE

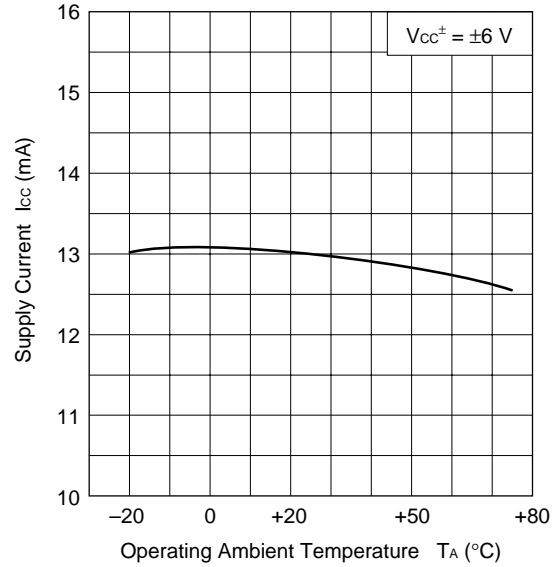

SUPPLY CURRENT vs. SUPPLY VOLTAGE

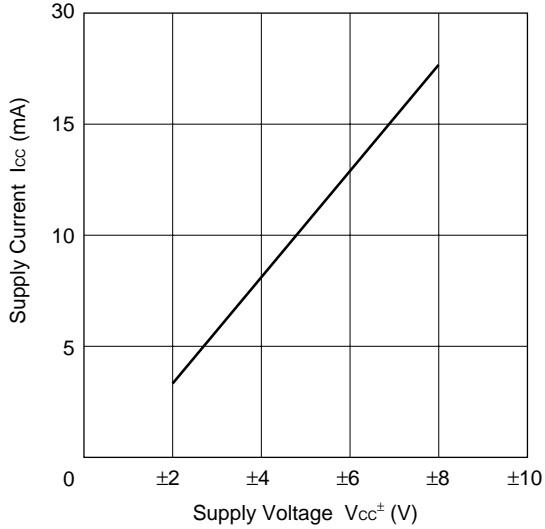

APPLICATION CIRCUIT EXAMPLES

EXAMPLE 1

Video Line Driver Circuit Example

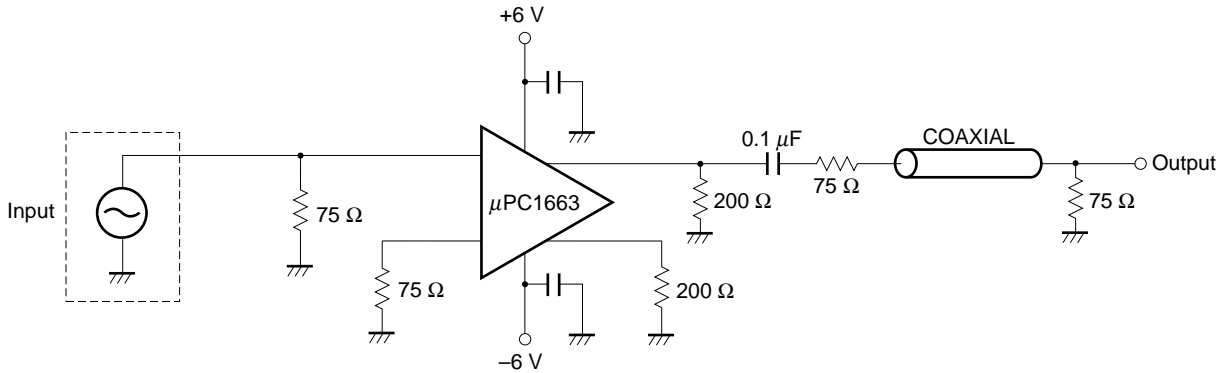

MAXIMUM OUTPUT VOLTAGE vs. FREQUENCY (VIDEO LINE, SINGLE-ENDED)

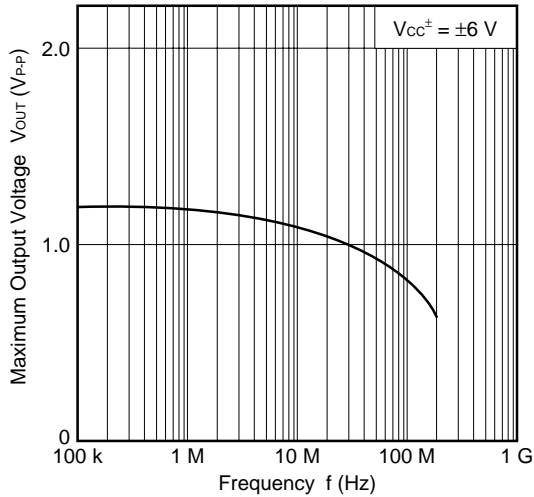

Remark
Differential output voltage is double of single-ended output voltage.

PHASE CHARACTERISTICS vs. FREQUENCY

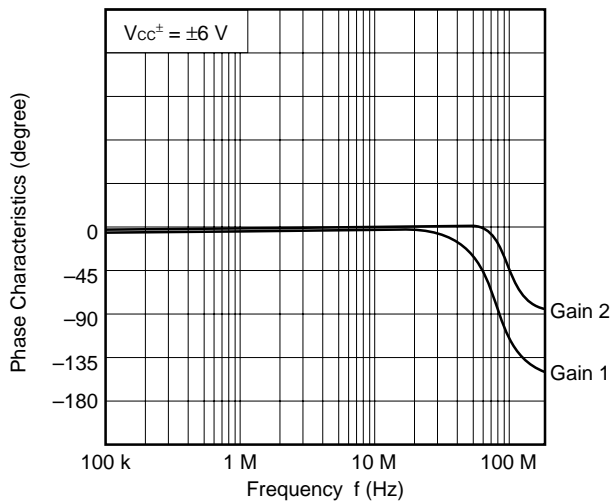

EXAMPLE 2

V_{CC} single supply application example (Outline)

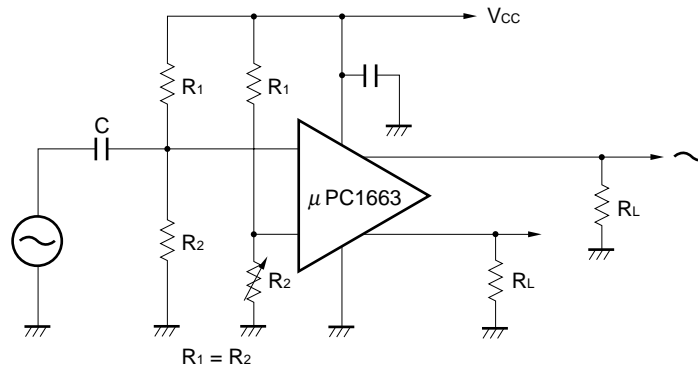

EXAMPLE 3

Photo signal detector circuit example (Outline)

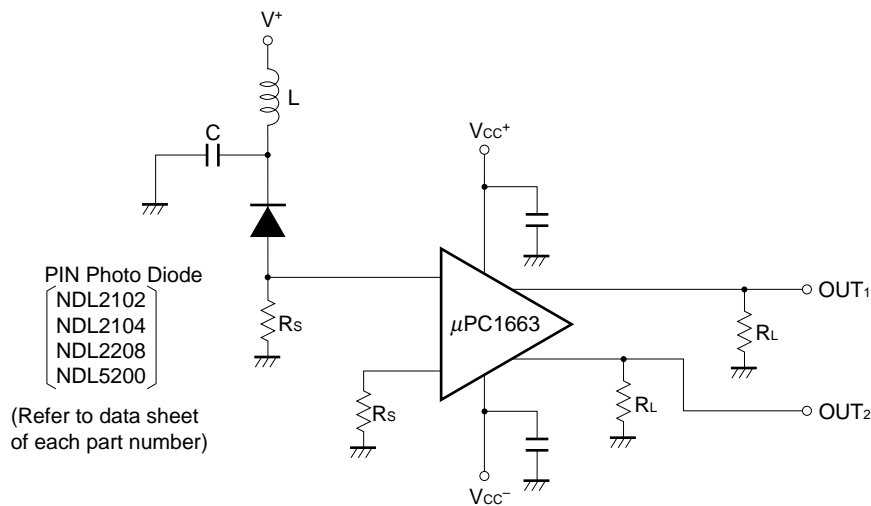

Caution When signal source impedance for μPC1663 is critical, FET source follower buffer should be inserted between PIN Photo diode and μPC1663 input.

The application circuits and their parameters are for reference only and are not intended for use in actual design-ins.

Precautions for design in and detail application circuit examples should be referred to application note 'Usage of μPC1663 (Document No. G12290E)'.

PACKAGE DIMENSIONS

★ 8 PIN PLASTIC SOP (225 mil) (Unit: mm)

– μPC1663G –

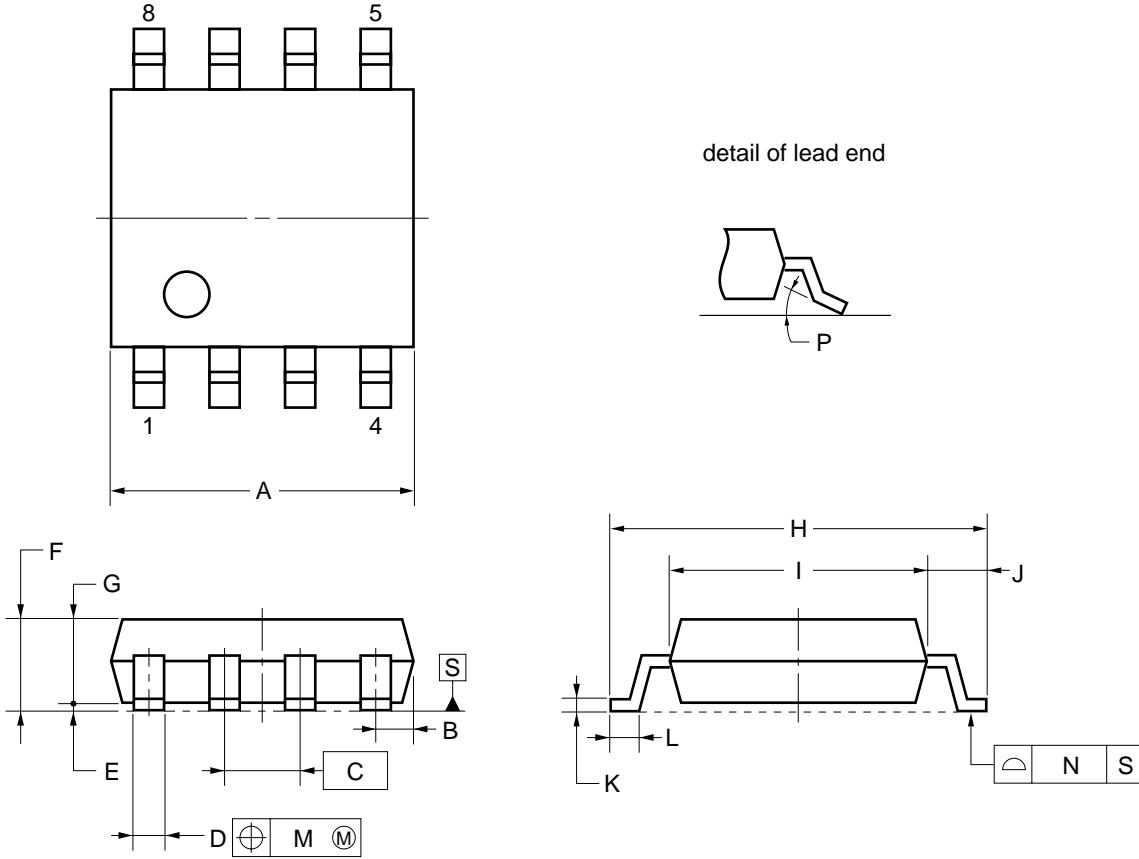

NOTE

Each lead centerline is located within 0.12 mm of its true position (T.P.) at maximum material condition.

ITEM	MILLIMETERS
A	5.2±0.2
B	0.85 MAX.
C	1.27 (T.P.)
D	0.42 ^{+0.08} _{-0.07}
E	0.1±0.1
F	1.57±0.2
G	1.49
H	6.5±0.3
I	4.4±0.15
J	1.1±0.2
K	0.17 ^{+0.08} _{-0.07}
L	0.6±0.2
M	0.12
N	0.10
P	3° ^{+7°} _{-3°}

8 PIN PLASTIC SSOP (175 mil) (Unit: mm)

– μPC1663GV –

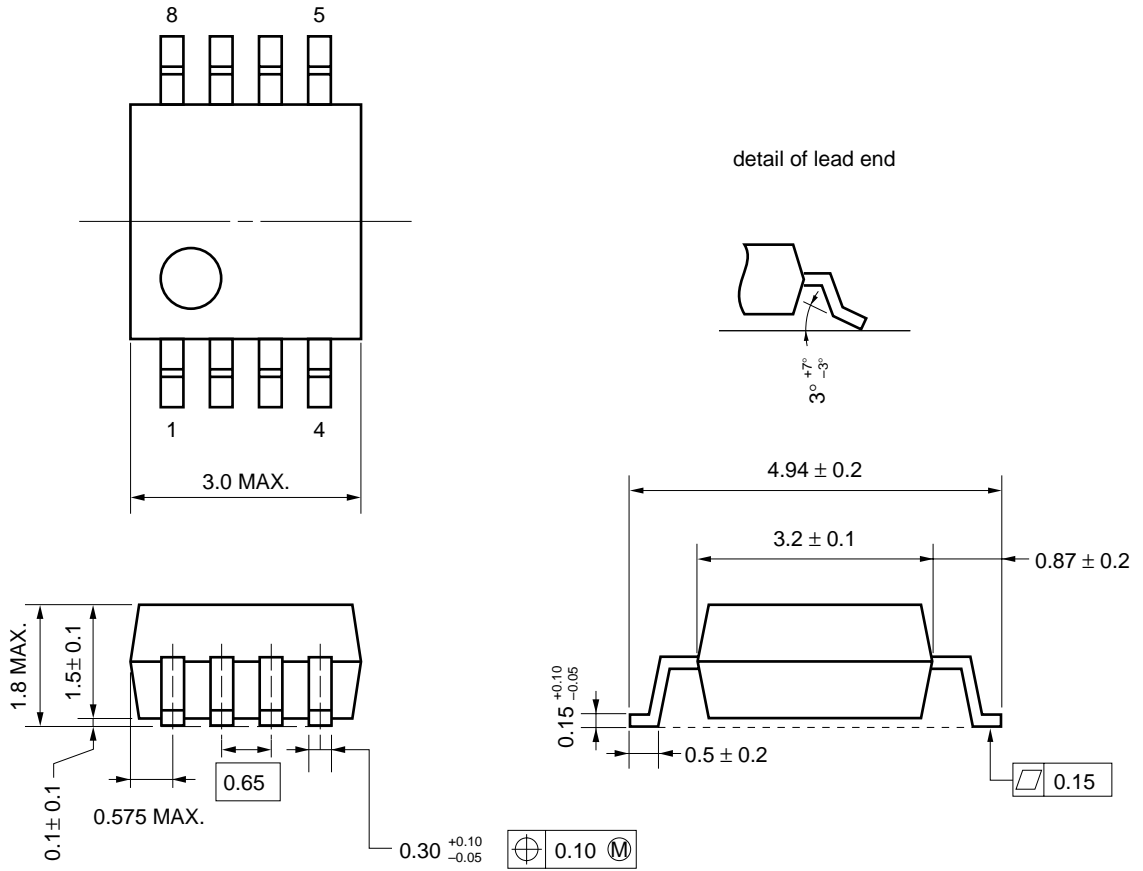

RECOMMENDED SOLDERING CONDITIONS

This product should be soldered under the following recommended conditions. For soldering methods and conditions other than those recommended below, contact your NEC sales representative.

Soldering Method	Soldering Conditions	Recommended Condition Symbol
Infrared Reflow	Package peak temperature: 235 °C or below Time: 30 seconds or less (at 210 °C) Count: 3, Exposure limit: None ^{Note}	IR35-00-3
VPS	Package peak temperature: 215 °C or below Time: 40 seconds or less (at 200 °C) Count: 3, Exposure limit: None ^{Note}	VP15-00-3
Wave Soldering	Soldering bath temperature: 260 °C or below Time: 10 seconds or less Count: 1, Exposure limit: None ^{Note}	WS60-00-1
Partial Heating	Pin temperature: 300 °C Time: 3 seconds or less (per side of device) Exposure limit: None ^{Note}	—

Note After opening the dry pack, keep it in a place below 25 °C and 65 % RH for the allowable storage period.

Caution Do not use different soldering methods together (except for partial heating).

For details of recommended soldering conditions for surface mounting, refer to information document SEMICONDUCTOR DEVICE MOUNTING TECHNOLOGY MANUAL (C10535E)

[MEMO]

[MEMO]

[MEMO]

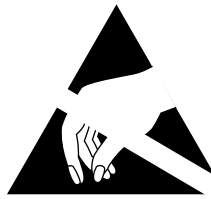

ATTENTION

OBSERVE PRECAUTIONS
FOR HANDLING
ELECTROSTATIC
SENSITIVE
DEVICES

NESAT (NEC Silicon Advanced Technology) is a trademark of NEC Corporation.

- **The information in this document is subject to change without notice. Before using this document, please confirm that this is the latest version.**
 - No part of this document may be copied or reproduced in any form or by any means without the prior written consent of NEC Corporation. NEC Corporation assumes no responsibility for any errors which may appear in this document.
 - NEC Corporation does not assume any liability for infringement of patents, copyrights or other intellectual property rights of third parties by or arising from use of a device described herein or any other liability arising from use of such device. No license, either express, implied or otherwise, is granted under any patents, copyrights or other intellectual property rights of NEC Corporation or others.
 - Descriptions of circuits, software, and other related information in this document are provided for illustrative purposes in semiconductor product operation and application examples. The incorporation of these circuits, software, and information in the design of the customer's equipment shall be done under the full responsibility of the customer. NEC Corporation assumes no responsibility for any losses incurred by the customer or third parties arising from the use of these circuits, software, and information.
 - While NEC Corporation has been making continuous effort to enhance the reliability of its semiconductor devices, the possibility of defects cannot be eliminated entirely. To minimize risks of damage or injury to persons or property arising from a defect in an NEC semiconductor device, customers must incorporate sufficient safety measures in its design, such as redundancy, fire-containment, and anti-failure features.
 - NEC devices are classified into the following three quality grades:
"Standard", "Special", and "Specific". The Specific quality grade applies only to devices developed based on a customer designated "quality assurance program" for a specific application. The recommended applications of a device depend on its quality grade, as indicated below. Customers must check the quality grade of each device before using it in a particular application.
 - Standard: Computers, office equipment, communications equipment, test and measurement equipment, audio and visual equipment, home electronic appliances, machine tools, personal electronic equipment and industrial robots
 - Special: Transportation equipment (automobiles, trains, ships, etc.), traffic control systems, anti-disaster systems, anti-crime systems, safety equipment and medical equipment (not specifically designed for life support)
 - Specific: Aircraft, aerospace equipment, submersible repeaters, nuclear reactor control systems, life support systems or medical equipment for life support, etc.
- The quality grade of NEC devices is "Standard" unless otherwise specified in NEC's Data Sheets or Data Books. If customers intend to use NEC devices for applications other than those specified for Standard quality grade, they should contact an NEC sales representative in advance.