

# Svetlana 3CX15,000H3 Medium-Mu Industrial Power Triode



**T**he Svetlana™ 3CX15,000H3 is a high-performance ceramic/metal power triode designed for use in oscillator, amplifier, or modulator service. The ceramic is glazed to facilitate cleaning when used in an industrial environment. A modern mesh filament is used, replacing the old-fashioned hairpin construction. The improved mesh filament design ensures better mechanical rigidity and long lasting concentricity of the filament, contributing to longer life. The mesh filament also provides improved RF efficiency at VHF operation. Flexible leads connect to the filament terminals and a flange is connected to the grid. The flange provides a convenient way to mount the tube. The Svetlana 3CX15,000H3 is manufactured in the Svetlana Electron Devices complex in St. Petersburg, Russia. Svetlana has achieved the improved performance described above with exact replacement compatibility with the 3CX15,000H3 manufactured in the United States.



# Svetlana 3CX15,000H3

## General Characteristics

### Electrical

Filament	Thoriated-tungsten mesh
Voltage	6.3 ±0.315 V
Current @ 7.50V	162 ±10.0 A
Amplification factor (average)	20
Direct interelectrode capacitances (grounded filament):	
Input	55.0 pF
Output	1.5 pF
Feedback	34 pF
Maximum frequency for full ratings (CW)	90 MHz

### Mechanical

Cooling	Forced air
Base	Flying leads/flange
Socketing	None. Mounting flange
Operating position	Vertical, Base up or down
Maximum operating temperature	250° C
Maximum dimensions:	
Length	45.09 cm (17.75 in.)
Diameter	17.91 cm (7.05 in.)
Net weight	5.91 kg (13 lb)

### RF Power Oscillator or Amplifier, Class C, (Filtered DC Plate Power Supply)

Maximum Ratings		
DC plate voltage	12,000	V
DC plate current	6.0	A
Plate dissipation	15,000	W
Grid dissipation	500	W
DC grid voltage	-1000	V
DC grid current	-1.0	A
Plate input power	60,000	W

### Typical Operation (under load)

(Frequencies to 30MHz)			
DC plate voltage	7000	10,000	V
DC plate current	6.0	5.0	A
DC grid voltage	-600	-800	V
DC grid current	660	542	mA
Peak RF grid voltage	440	400	V
Driving Power	660	650	W
Grid dissipation	78	46	W
Plate input power	42,000	50,000	W
Plate dissipation	12,000	8,800	W
Plate output power	30,000	41,200	W
Approximate load impedance	600	1025	Ohms

# Medium-Mu Industrial Power Triode

## Electrical Application

**Filament Operation** The rated filament voltage for the 3CX15,000H3 is 6.30 volts. Filament voltage, as measured at the filament seals, should be maintained within 5% of this value. Maximum tube life will be obtained at -5%.

**Control Grid Operation** The maximum grid current rating should never be exceeded except for short periods such as tuning. Overcurrent protection in the grid circuit should be provided although in most applications the grid current will not exceed 0.6A. The widely varying loads in most industrial applications emphasises the need for continuous grid current monitoring.

**Plate Operation** Maximum plate voltage and current should never be permitted simultaneously. Plate current overload protection should be adjusted to remove plate voltage quickly in the event of an arc or other current overload. An added measure of safety is a spark gap from plate to ground to protect against an over voltage condition.

## Mechanical Application

**Mounting** The 3CX15,000H3 must be mounted with its axis vertical. The base of the tube may be up or down.

**Filament Connections** The Svetlana 3CX15,000H3 filament connections are made via the attached flexible leads.

**Grid Connection** The mounting flange is also the electrical connection to the grid.

**Cooling** Sufficient forced-air circulation must be provided to keep the temperature of the anode core and the temperatures of the ceramic/metal seals below 250°C.

Airflow requirements to maintain these temperatures below 225°C with an inlet-air temperature of 50°C are tabulated. Adequate airflow must be directed over the lead-to-tube connections for the grid and filament leads. At frequencies above 30 MHz or at higher inlet-air temperatures or higher altitudes, more airflow will be required. The joints between the filament leads and the tube surfaces must be adequately cooled.

Anode-to-Base Air Flow <sup>1</sup>				
Anode Dissipation Watts	Sea Level		5000 Feet	
	Air Flow CFM	Pressure Drop Inches of Water	Air Flow CFM	Pressure Drop Inches of Water
7500	361	1.63	433	1.96
10,000	606	3.26	728	3.92
15,000	1260	10.00	1510	12.00

<sup>1</sup> A minimum of 16 cfm must be directed into the filament-stem structure below the outer filament contact ring to maintain the base seals below 250° C.

# Svetlana 3CX15,000H3

## Svetlana 3CX15,000H3 Industrial Triode Outline Drawing

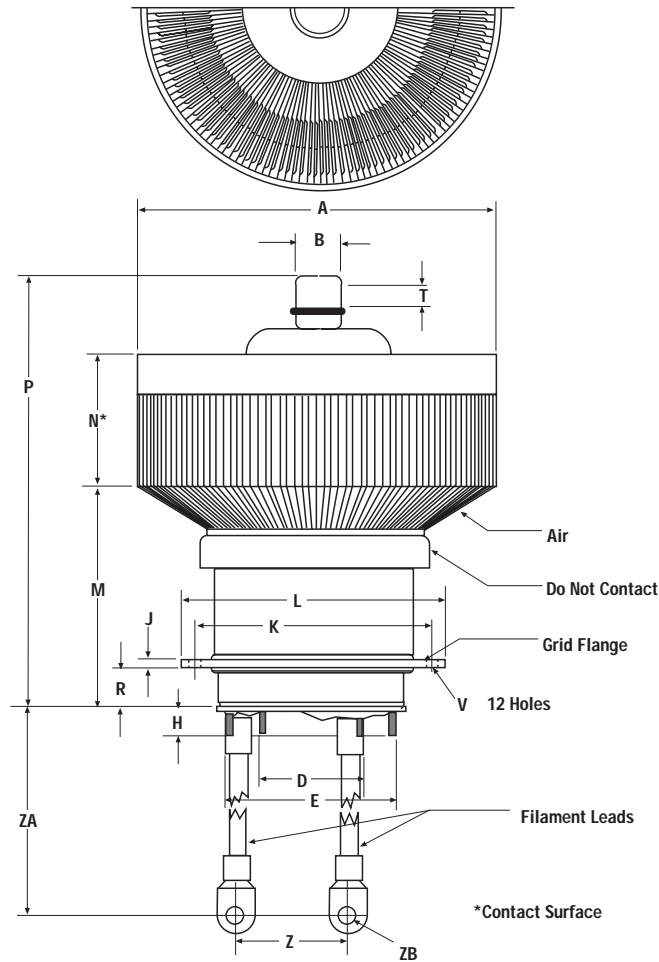

Dimensional Data						
Dim.	Millimeters			Inches		
	Ref	Min.	Max.	Ref	Min.	Max.
A	—	175.97	179.07	—	6.928	7.050
B	—	21.72	22.73	—	0.855	0.895
D	47.63	—	—	1.875	—	—
E	82.55	—	—	3.250	—	—
H	—	13.46	17.78	—	0.530	0.700
J	3.18	—	—	0.125	—	—
K	—	112.40	112.90	—	4.425	4.445
L	—	127.62	129.29	—	5.030	5.090
M	—	100.33	109.22	—	3.950	4.300
N	—	61.27	70.82	—	2.412	2.788
P	—	209.55	222.25	—	8.250	8.750
R	—	17.78	21.84	—	0.700	0.860
T	—	9.53	—	—	0.375	—
V	6.35	—	—	0.250	—	—
Z	50.8	—	—	2.000	—	—
ZA	—	215.9	228.6	—	8.500	9.000
ZB	9.91	—	—	0.390	—	—

# Medium-Mu Power Industrial Triode

