

MECHANICAL CASE OUTLINE
PACKAGE DIMENSIONS

TO-220FI5H
CASE 221AN
ISSUE 0

DATE 30 JAN 2012

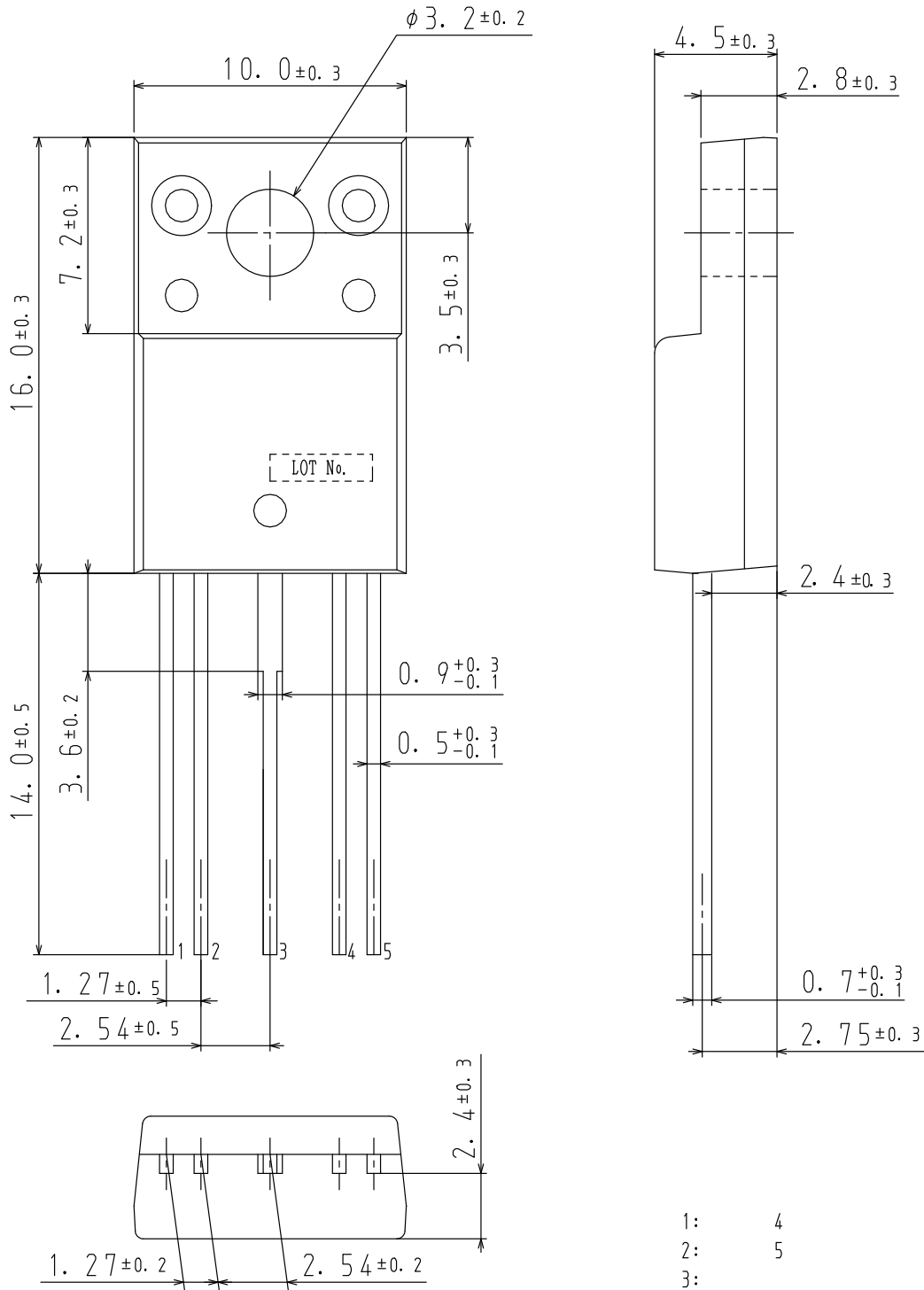

- 1: 4
- 2: 5
- 3:

DOCUMENT NUMBER:	98AON66227E	Electronic versions are uncontrolled except when accessed directly from the Document Repository. Printed versions are uncontrolled except when stamped "CONTROLLED COPY" in red.
STATUS:	ON SEMICONDUCTOR STANDARD	
NEW STANDARD:		
DESCRIPTION:	TO-220FI5H	PAGE 1 OF 2

