

ULTRA LOW_{rec} (sat)
SILICON EPITAXIAL JUNCTION
PNP/NPN SWITCHING TRANSISTORS

2N3677
2N5066

- COMPLEMENTARY TYPES 2N3677 (PNP) 2N5066(NPN)
- r_{ec} (sat) 4 Ohms TYPICAL
- LOW C_{eb}
- LOW LEAKAGE
- HIGH BV_{EBO}

ELECTRICAL DATA ABSOLUTE MAXIMUM RATINGS

PARAMETER	SYMBOL	2N3677/2N5066	UNITS
Collector to Emitter Voltage	BV_{CES}	20	Volts
Emitter to Collector Voltage	BV_{ECS}	20	Volts
Collector to Base Voltage	BV_{CBO}	30	Volts
Emitter to Base Voltage	BV_{EBO}	30	Volts
Collector Current	I_C	100	mA
Power Dissipation	P_C	400	mW
Derating Factor	D_F	2.3	mW/°C
Junction Temperature (operating and storage)	T_J	-65°C to +200°C	
Lead Temperature (1/16" ± 1/32" from case)	T_L	240°C for 10 sec.	

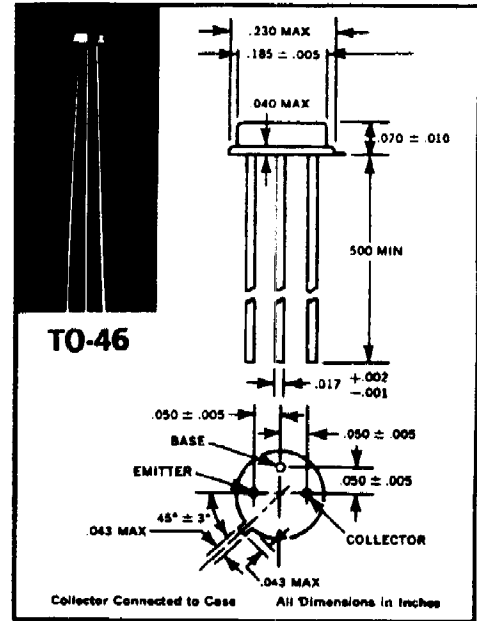

ELECTRICAL CHARACTERISTICS: $T_A = 25^\circ C$ (UNLESS OTHERWISE STATED)

PARAMETER	SYMBOL	CONDITION	2N3677/2N5066			UNITS
			Min.	Typ.	Max.	
Collector To Base Leakage	I_{CBO}	$V_{CB} = V_{CB}MAX.$	—	0.5	1.0	nA
Emitter to Base Leakage	I_{EBO}	$V_{EB} = V_{EB}MAX.$	—	0.5	1.0	nA
Collector To Base Leakage	I_{CBO}	$V_{CB} = V_{CB}MAX.$ (TEMP = 100°C)	—	30	100	nA
Emitter To Base Leakage	I_{EBO}	$V_{EB} = V_{EB}MAX.$ (TEMP = 100°C)	—	30	100	nA
Offset Voltage	V_O	$I_B = 1mA$ $I_E = 0$	—	0.7	1.0	mV
DC Common Collector Forward Current Transfer Ratio	h_{FC}	$V_{EC} = 6V$ $I_E = 1mA$	4	8	—	—
High Frequency Current Gain	h_{fe}	$V_{CE} = 6V, I_C = 1mA$ $f = 1MC$	5	10	—	—
Inverted Dynamic Saturation Resistance	$r_{ec}(sat)$	$I_o = 0.1mA$ $I_b = 1.0mA$ $f = 1kHz$	—	4	8	Ohms
Collector To Base Capacitance	C_{ob}	$V_{CB} = 6V, I_C = 1mA, f = 159kHz$	—	6	10	pf
Emitter To Base Capacitance	C_{eb}	$V_{EB} = 6V, I_E = 0, f = 159kHz$	—	5	6	pf

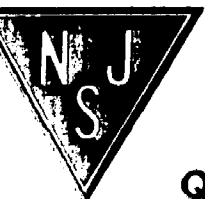

NJ Semi-Conductors reserves the right to change test conditions, parameters limits and package dimensions without notice information furnished by NJ Semi-Conductors is believed to be both accurate and reliable at the time of going to press. However NJ Semi-Conductors assumes no responsibility for any errors or omissions discovered in its use. NJ Semi-Conductors encourages customers to verify that datasheets are current before placing orders.

Quality Semi-Conductors