

HIGH-CURRENT SWITCH

DESCRIPTION

The 2N3724 is a silicon planar epitaxial transistor in TO-39 metal case. It is a high-current switch used for memory applications requiring breakdown voltages up to 30 V and operating currents to 1 A.

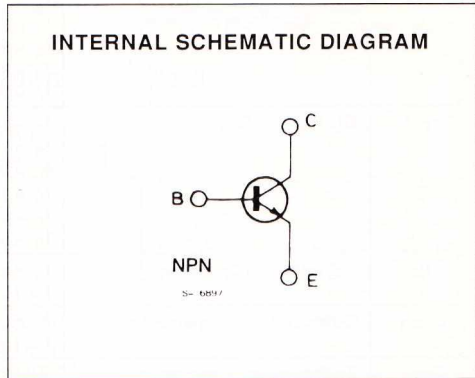
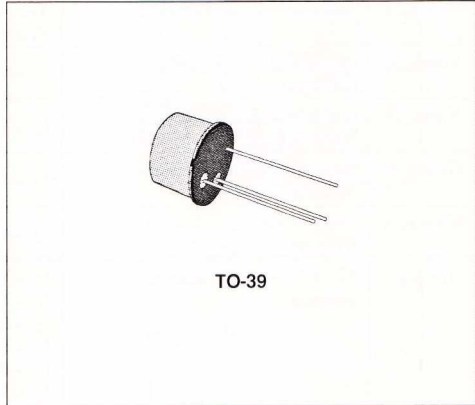

ABSOLUTE MAXIMUM RATINGS

Symbol	Parameter	Value	Unit
V_{CBO}	Collector-base Voltage ($I_E = 0$)	50	V
V_{CES}	Collector-emitter Voltage ($V_{BE} = 0$)	50	V
V_{CEO}	Collector-emitter Voltage ($I_B = 0$)	30	V
V_{EBO}	Emitter-base Voltage ($I_C = 0$)	6	V
I_C	Collector Current	1	A
P_{tot}	Total Power Dissipation at $T_{amb} \leq 25\text{ }^\circ\text{C}$ at $T_{case} \leq 25\text{ }^\circ\text{C}$	0.8	W
		3.5	W
T_{stg}, T_J	Storage and Junction Temperature	- 65 to 200	$^\circ\text{C}$

THERMAL DATA

$R_{th\ j-case}$	Thermal Resistance Junction-case	Max	50	$^{\circ}C/W$
$R_{th\ j-amb}$	Thermal Resistance Junction-ambient	Max	220	$^{\circ}C/W$

ELECTRICAL CHARACTERISTICS ($T_{amb} = 25\ ^{\circ}C$ unless otherwise specified)

Symbol	Parameter	Test Conditions	Min.	Typ.	Max.	Unit
I_{CBO}	Collector Cutoff Current ($I_E = 0$)	$V_{CB} = 40\ V$ $V_{CB} = 40\ V$ $T_{amb} = 100\ ^{\circ}C$			1.7 120	μA μA
$V_{(BR)CBO}$	Collector-base Breakdown Voltage ($I_E = 0$)	$I_C = 10\ \mu A$	50			V
$V_{(BR)CES}$	Collector-emitter Breakdown Voltage ($V_{BE} = 0$)	$I_C = 10\ \mu A$	50			V
$V_{(BR)CEO}^*$	Collector-emitter Breakdown Voltage ($I_B = 0$)	$I_C = 10\ mA$	30			V
$V_{(BR)EBO}$	Emitter-base Breakdown Voltage ($I_C = 0$)	$I_E = 10\ \mu A$	6			V
$V_{CE(sat)}^*$	Collector-emitter Saturation Voltage	$I_C = 10\ mA$ $I_B = 1\ mA$ $I_C = 100\ mA$ $I_B = 10\ mA$ $I_C = 300\ mA$ $I_B = 30\ mA$ $I_C = 500\ mA$ $I_B = 50\ mA$ $I_C = 800\ mA$ $I_B = 80\ mA$ $I_C = 1000\ mA$ $I_B = 100\ mA$			0.25 0.20 0.32 0.42 0.65 0.75	V V V V V V
$V_{BE(sat)}^*$	Base-emitter Saturation Voltage	$I_C = 10\ mA$ $I_B = 1\ mA$ $I_C = 100\ mA$ $I_B = 10\ mA$ $I_C = 300\ mA$ $I_B = 30\ mA$ $I_C = 500\ mA$ $I_B = 50\ mA$ $I_C = 800\ mA$ $I_B = 80\ mA$ $I_C = 1000\ mA$ $I_B = 100\ mA$	0.9	0.64 0.75 0.89	0.76 0.86 1.1 1.2 1.5 1.7	V V V V V V
h_{FE}^*	DC Current Gain	$I_C = 10\ mA$ $V_{CE} = 1\ V$ $I_C = 100\ mA$ $V_{CE} = 1\ V$ $I_C = 300\ mA$ $V_{CE} = 1\ V$ $I_C = 1000\ mA$ $V_{CE} = 5\ V$ $I_C = 800\ mA$ $V_{CE} = 2\ V$ $I_C = 500\ mA$ $V_{CE} = 1\ V$	30 60 40 30 25 35	60 90 60	150	
h_{fe}	High Frequency Current Gain	$I_C = 50\ mA$ $V_{CE} = 10\ V$ $f = 100\ MHz$	3			
C_{CBO}	Collector-base Capacitance	$I_C = 0$ $V_{CB} = 10\ V$ $f = 1\ MHz$			12	pF
C_{EBO}	Emitter-base Capacitance	$I_C = 0$ $V_{EB} = 0.5\ V$ $f = 1\ MHz$			55	pF
t_{on}^{**}	Turn-on Time	$I_C = 500\ mA$ $V_{CC} = 30\ V$ $I_B = 50\ mA$			35	ns
t_{off}^{**}	Turn off Time	$I_C = 500\ mA$ $V_{CC} = 30\ V$ $I_{B1} = -I_{B2} = 50\ mA$			60	ns

* Pulsed : pulse duration = 300 μs , duty cycle = 1 %.

** See test circuit.

Switching Characteristics.

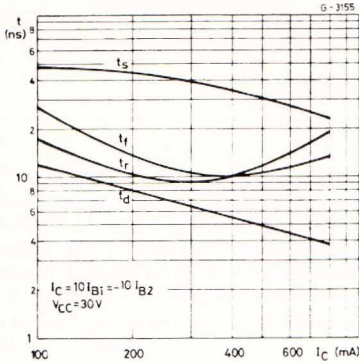

Switching Characteristics.

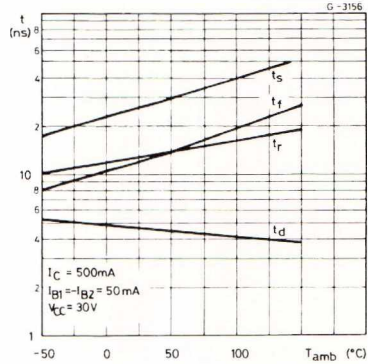

Test Circuit for ton, toff.

