

Silicon NPN Power Transistors

2N6687

DESCRIPTION

- With TO-3 package
- Fast switching speed
- Low collector saturation voltage

APPLICATIONS

- For power supplies and other high-voltage switching applications

PINNING

PIN	DESCRIPTION
1	Base
2	Emitter
3	Collector

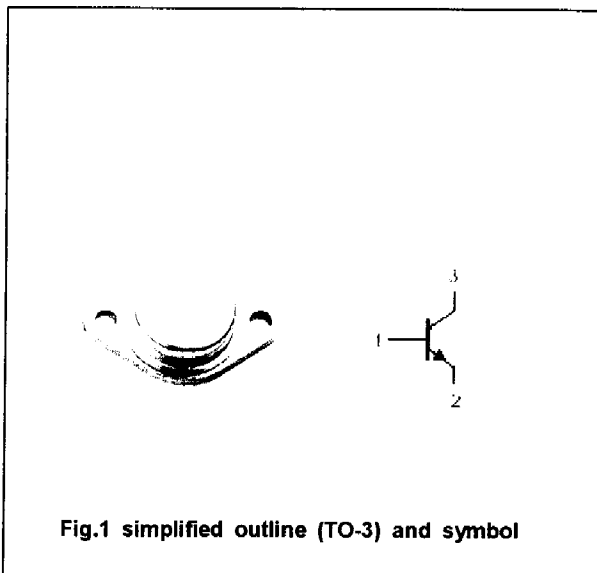

Fig.1 simplified outline (TO-3) and symbol

Absolute maximum ratings(Ta=□)

SYMBOL	PARAMETER	CONDITIONS	VALUE	UNIT
V _{CBO}	Collector-base voltage	Open emitter	280	V
V _{CEO}	Collector-emitter voltage	Open base	180	V
V _{EBO}	Emitter-base voltage	Open collector	8	V
I _C	Collector current		25	A
I _{CM}	Collector current-peak		50	A
I _B	Base current		8	A
P _C	Collector power dissipation	T _C =25 _L	200	W
T _J	Junction temperature		200	L
T _{stg}	Storage temperature		-65~200	L

THERMAL CHARACTERISTICS

SYMBOL	PARAMETER	VALUE	UNIT
R _{th j-c}	Thermal resistance junction to case	0.875	L/W

NJ Semi-Conductors reserves the right to change test conditions, parameters limits and package dimensions without notice information furnished by NJ Semi-Conductors is believed to be both accurate and reliable at the time of going to press. However NJ Semi-Conductors assumes no responsibility for any errors or omissions discovered in its use. NJ Semi-Conductors encourages customers to verify that datasheets are current before placing orders.

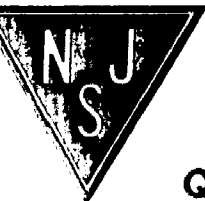

CHARACTERISTICS

T_j=25° unless otherwise specified

SYMBOL	PARAMETER	CONDITIONS	MIN	TYP.	MAX	UNIT
V _{CE0(SUS)}	Collector-emitter sustaining voltage	I _C =0.2A ; I _B =0	180			V
V _{CEsat}	Collector-emitter saturation voltage	I _C =25A ; I _B =2.5A			1.5	V
V _{BEsat}	Base-emitter saturation voltage	I _C =25A ; I _B =2.5A			1.8	V
I _{CEV}	Collector cut-off current	V _{CE} =280V ; V _{BE} =-1.5V			50	μA
I _{EBO}	Emitter cut-off current	V _{EB} =8V ; I _C =0			100	μA
h _{FE-1}	DC current gain	I _C =1A ; V _{CE} =2V	30			
h _{FE-2}	DC current gain	I _C =10A ; V _{CE} =2V	25		100	
h _{FE-3}	DC current gain	I _C =25A ; V _{CE} =2V	15			
f _T	Transition frequency	I _C =1A ; V _{CE} =10V	20		100	MHz

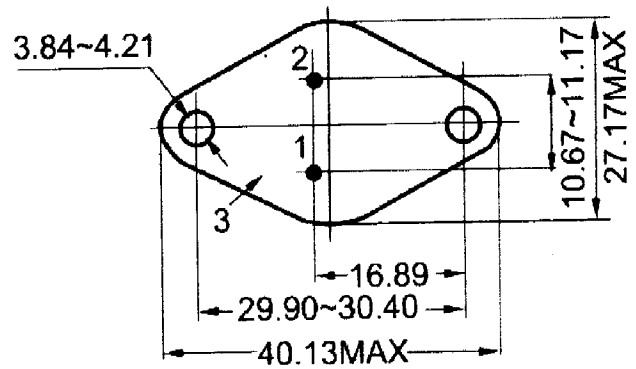
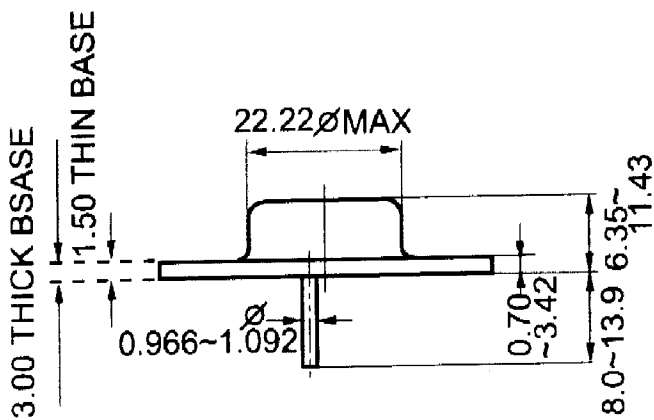

Fig.2 outline dimensions (unindicated tolerance:±0.1mm)