



2SA940

PNP EPITAXIAL SILICON TRANSISTOR

**POWER AMPLIFIER
VERTICAL DEFLECTION OUTPUT**

- Complementary to 2SC2073

ABSOLUTE MAXIMUM RATING (Ta=25°C)

Characteristic	Symbol	Rating	Unit
Collector-Base Voltage	VCBO	-150	V
Collector-Emitter Voltage	VCEO	-150	V
Emitter-Base voltage	VEBO	-5	V
Collector Current (DC)	IC	-1.5	A
Collector Dissipation	PC	25	W
Junction Temperature	Tj	150	°C
Storage Temperature	Tstg	-50~150	°C

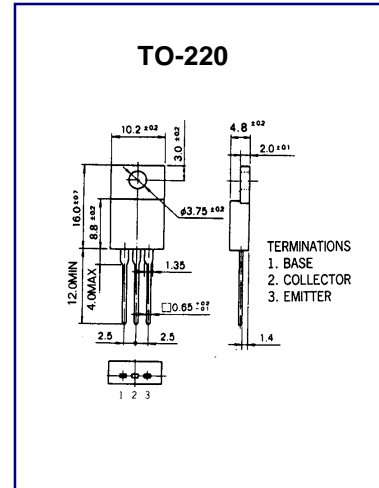

ELECTRICAL CHARACTERISTICS (Ta=25°C)

Characteristic	Symbol	Test Condition	Min	Typ	Max	Unit
Collector Cutoff Current	ICBO	VCB= -120V, IE=0			-10	μA
Emitter Cutoff Current	IEBO	VEB= -5V, IC=0			10	μA
DC Current Gain	hFE	VCE= -10V, IC=-0.5A	40		75	
Collector- Emitter Saturation Voltage	VCE(sat)	IC=-0.5, IB=-50mA			-1.5	V
Current Gain Bandwidth Product	fT	VCE= -10V, IC=-0.5A		4		MHZ