

RF & MICROWAVE TRANSISTORS S-BAND RADAR APPLICATIONS

- REFRACTORY/GOLD METALLIZATION
- EMITTER SITE BALLASTED
- LOW THERMAL RESISTANCE
- INPUT/OUTPUT MATCHING
- OVERLAY GEOMETRY
- METAL/CERAMIC HERMETIC PACKAGE
- P_{OUT} = 10 W MIN. WITH 5.0 dB GAIN

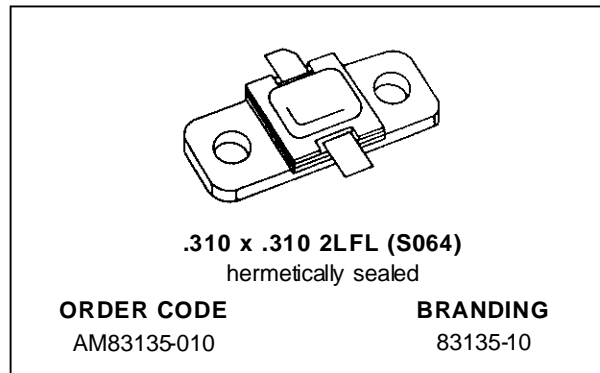

DESCRIPTION

The AM83135-010 device is a high power silicon bipolar NPN transistor specifically designed for S-Band radar pulsed output and driver applications.

This device is characterized at 100μsec pulse width and 10% duty cycle, but is capable of operation over a range of pulse widths, duty cycles, and temperatures, and can withstand a 3:1 output VSWR with a + 1 dB input overdrive. Low RF thermal resistance, refractory/gold metallization, and computerized automatic wire bonding techniques ensure high reliability and product consistency (including phase characteristics).

The AM83135-010 is supplied in the IMPAC™ hermetic metal/ceramic package with internal input/output impedance matching circuitry, and is intended for military and other high reliability applications.

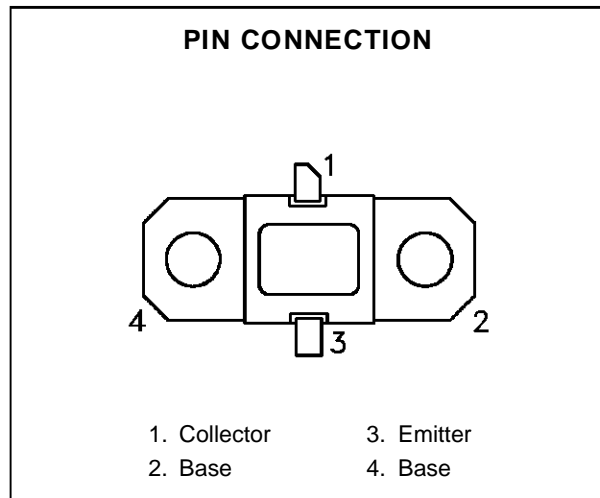

ABSOLUTE MAXIMUM RATINGS (T_{case} = 25°C)

Symbol	Parameter	Value	Unit
P _{DISS}	Power Dissipation* (T _c ≤ 50°C)	50	W
I _c	Device Current*	2	A
V _{CC}	Collector-Supply Voltage*	46	V
T _J	Junction Temperature (Pulsed RF Operation)	250	°C
T _{STG}	Storage Temperature	- 65 to +200	°C

THERMAL DATA

R _{TH(j-c)}	Junction-Case Thermal Resistance*	4.0	°C/W
----------------------	-----------------------------------	-----	------

*Applies only to rated RF amplifier operation

AM83135-010

ELECTRICAL SPECIFICATIONS (T_{case} = 25°C)

STATIC

Symbol	Test Conditions		Value			Unit
			Min.	Typ.	Max.	
BV _{CBO}	I _C = 7 mA	I _E = 0 mA	55	—	—	V
BV _{EBO}	I _E = 1 mA	I _C = 0 mA	3.5	—	—	V
BV _{CER}	I _C = 7 mA	R _{BE} = 10 Ω	55	—	—	V
I _{CES}	V _{BE} = 0 V	V _{CE} = 40 V	—	—	5	mA
h _{FE}	V _{CE} = 5 V	I _C = 600 mA	30	—	—	—

DYNAMIC

Symbol	Test Conditions			Value			Unit
				Min.	Typ.	Max.	
P _{OUT}	f = 3.1 – 3.5 GHz	P _{IN} = 3.2 W	V _{CC} = 40 V	10	—	—	W
η _C	f = 3.1 – 3.5 GHz	P _{OUT} = 10 W	V _{CC} = 40 V	30	—	—	%
P _G	f = 3.1 – 3.5 GHz	P _{OUT} = 10 W	V _{CC} = 40 V	5.0	—	—	dB

Note: Pulse Width = 100μSec
Duty Cycle = 10%

TYPICAL PERFORMANCE

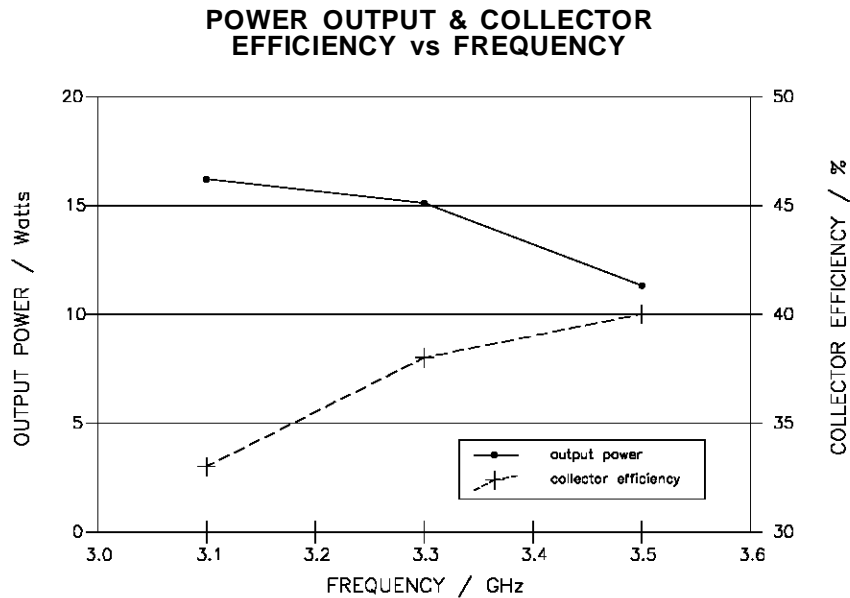

IMPEDANCE DATA

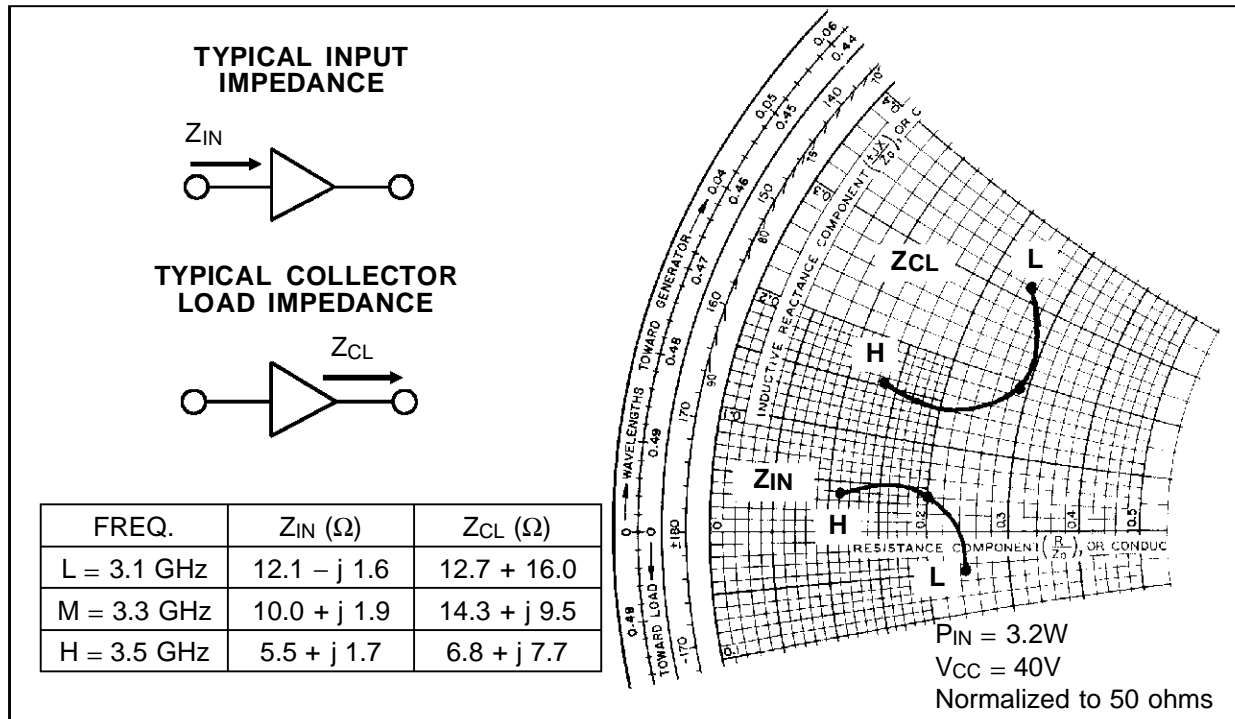

TEST CIRCUIT

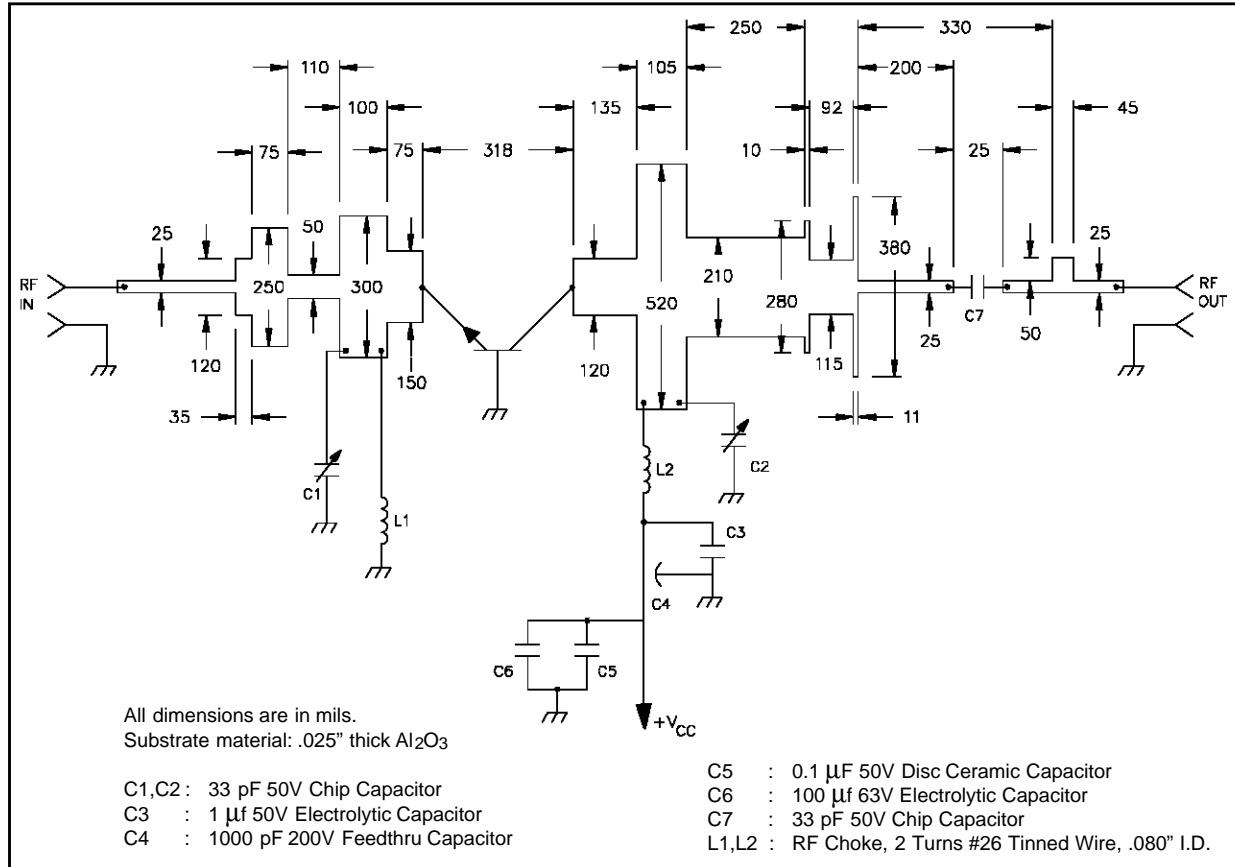

PACKAGE MECHANICAL DATA

Ref.: Dwg. No. 12-0221 rev. A

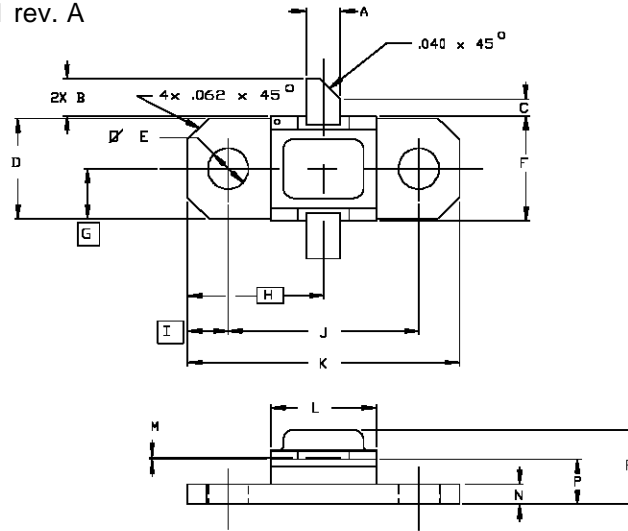

SGS-THOMSON MICROELECTRONICS		CONT'D			
	MINIMUM Inches/mm	MAXIMUM Inches/mm		MINIMUM Inches/mm	MAXIMUM Inches/mm
A	.095/2,41	.105/2,67	K	.790/20,07	.810/20,57
B	.100/2,54	.120/3,05	L	.300/7,62	.320/8,13
C	.050/1,27		M	.003/0,08	.006/0,15
D	.286/7,26	.306/7,77	N	.052/1,32	.072/1,83
E	.110/2,79	.130/3,30	P	.118/3,00	.131/3,33
F	.306/7,77	.319/8,09	R		.230/5,84
G	.148/3,76				
H	.400/10,16				
I	.119/3,02				
J	.552/14,02	.572/14,53			

Information furnished is believed to be accurate and reliable. However, SGS-THOMSON Microelectronics assumes no responsibility for the consequences of use of such information nor for any infringement of patents or other rights of third parties which may result from its use. No license is granted by implication or otherwise under any patent or patent rights of SGS-THOMSON Microelectronics. Specifications mentioned in this publication are subject to change without notice. This publication supersedes and replaces all information previously supplied. SGS-THOMSON Microelectronics products are not authorized for use as critical components in life support devices or systems without express written approval of SGS-THOMSON Microelectronics.

©1994 SGS-THOMSON Microelectronics - All Rights Reserved

SGS-THOMSON Microelectronics GROUP OF COMPANIES
 Australia - Brazil - France - Germany - Hong Kong - Italy - Japan - Korea - Malaysia - Malta - Morocco - The Netherlands -
 Singapore - Spain - Sweden - Switzerland - Taiwan - Thailand - United Kingdom - U.S.A.