

BCW61B
BCW61C
BCW61D

**SURFACE MOUNT
PNP SILICON TRANSISTOR**

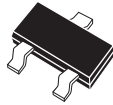

SOT-23 CASE

Central™

Semiconductor Corp.

DESCRIPTION:

The CENTRAL SEMICONDUCTOR BCW61B Series types are PNP Silicon Transistors manufactured by the epitaxial planar process, epoxy molded in a surface mount package, designed for low level, low noise applications.

**MARKING CODES: BCW61B : BB
BCW61C : BC
BCW61D : BD**

MAXIMUM RATINGS ($T_A=25^\circ\text{C}$)

	SYMBOL		UNITS
Collector-Emitter Voltage	V_{CEO}	32	V
Collector-Base Voltage	V_{CBO}	32	V
Emitter-Base Voltage	V_{EBO}	5.0	V
Collector Current	I_C	100	mA
Power Dissipation	P_D	350	mW
Operating and Storage Junction Temperature	T_J, T_{stg}	-65 to +150	$^\circ\text{C}$
Thermal Resistance	Θ_{JA}	357	$^\circ\text{C/W}$

ELECTRICAL CHARACTERISTICS ($T_A=25^\circ\text{C}$ unless otherwise noted)

SYMBOL	TEST CONDITIONS	MIN	MAX	UNITS
I_{CES}	$V_{CE}=32\text{V}$		20	nA
I_{CES}	$V_{CE}=32\text{V}, T_A=150^\circ\text{C}$		20	μA
BV_{CEO}	$I_C=2.0\text{mA}$	32		V
BV_{EBO}	$I_E=1.0\mu\text{A}$	5.0		V
$V_{CE(SAT)}$	$I_C=10\text{mA}, I_B=250\mu\text{A}$		0.25	V
$V_{CE(SAT)}$	$I_C=50\text{mA}, I_B=1.25\text{mA}$		0.55	V
$V_{BE(SAT)}$	$I_C=10\text{mA}, I_B=250\mu\text{A}$	0.60	0.85	V
$V_{BE(SAT)}$	$I_C=50\text{mA}, I_B=1.25\text{mA}$	0.68	1.05	V
$V_{BE(ON)}$	$V_{CE}=5.0\text{V}, I_C=2.0\text{mA}$	0.60	0.75	V
C_{ob}	$V_{CB}=10\text{V}, I_C=0, f=1.0\text{MHz}$		6.0	pF
NF	$V_{CE}=5.0\text{V}, I_C=0.2\text{mA}, R_S=2.0\text{k}\Omega, f=1.0\text{kHz}, BW=200\text{Hz}$		6.0	dB
t_{on}	$V_{CC}=10\text{V}, I_C=10\text{mA}, R_L=990\Omega, I_{B1}=I_{B2}=1.0\text{mA}$		150	ns
t_{on}	$V_{CC}=10\text{V}, I_C=10\text{mA}, R_L=990\Omega, I_{B1}=I_{B2}=1.0\text{mA}$		800	ns

		BCW61B		BCW61C		BCW61D	
		MIN	MAX	MIN	MAX	MIN	MAX
h_{FE}	$V_{CE}=5.0\text{V}, I_C=10\mu\text{A}$	30		40		100	
h_{FE}	$V_{CE}=5.0\text{V}, I_C=2.0\text{mA}$	140	310	250	460	380	630
h_{FE}	$V_{CE}=1.0\text{V}, I_C=50\text{mA}$	80		100		100	
h_{fe}	$V_{CE}=5.0\text{V}, I_C=2.0\text{mA}, f=1.0\text{kHz}$	175	350	250	500	350	700

**SURFACE MOUNT
PNP SILICON TRANSISTOR**

SOT-23 CASE - MECHANICAL OUTLINE

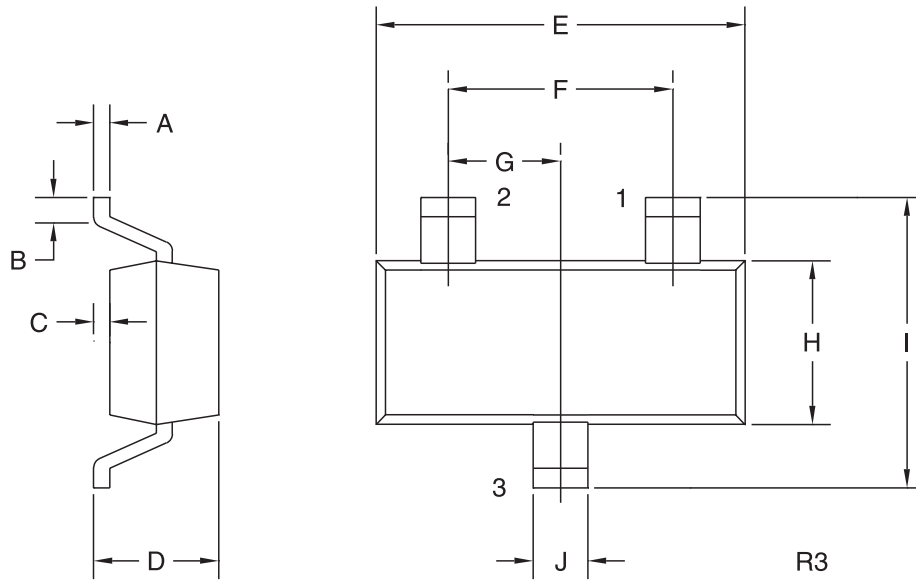

LEAD CODE:

- 1) BASE
- 2) EMITTER
- 3) COLLECTOR

MARKING CODES: BCW61B : BB
BCW61C : BC
BCW61D : BD

DIMENSIONS				
SYMBOL	INCHES		MILLIMETERS	
	MIN	MAX	MIN	MAX
A	0.003	0.007	0.08	0.18
B	0.006	-	0.15	-
C	-	0.005	-	0.13
D	0.035	0.043	0.89	1.09
E	0.110	0.120	2.80	3.05
F	0.075		1.90	
G	0.037		0.95	
H	0.047	0.055	1.19	1.40
I	0.083	0.098	2.10	2.49
J	0.014	0.020	0.35	0.50

SOT-23 (REV: R3)