

# DATA SHEET

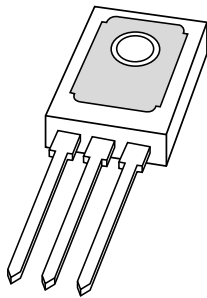

## **BF470; BF472** PNP high-voltage transistors

Product specification  
Supersedes data of September 1994  
File under Discrete Semiconductors, SC04

1996 Dec 09

# PNP high-voltage transistors

# BF470; BF472

### FEATURES

- Low feedback capacitance.

### APPLICATIONS

- Class-B video output stages in television receivers and for high-voltage IF output stages.

### DESCRIPTION

PNP transistors in a TO-126; SOT32 plastic package.  
NPN complements: BF469 and BF471.

### PINNING

PIN	DESCRIPTION
1	emitter
2	collector, connected to mounting base
3	base

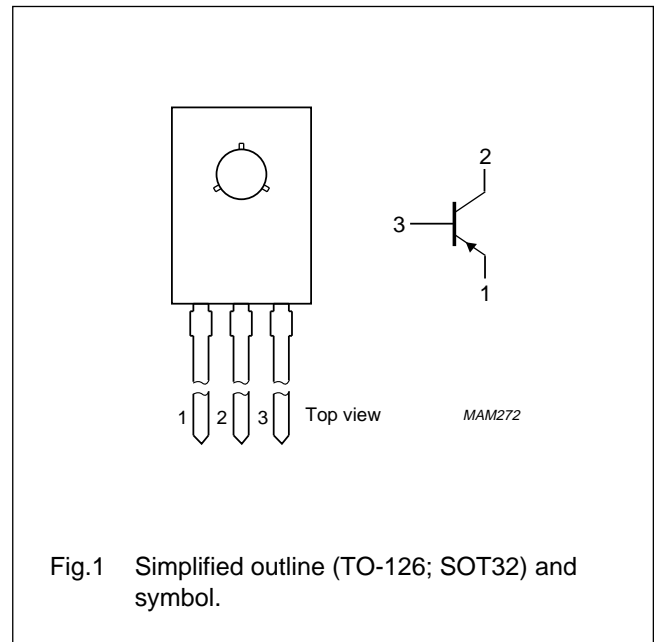

### QUICK REFERENCE DATA

SYMBOL	PARAMETER	CONDITIONS	MIN.	MAX.	UNIT
V <sub>CBO</sub>	collector-base voltage	open emitter			
	BF470		–	–250	V
	BF472		–	–300	V
V <sub>CEO</sub>	collector-emitter voltage	open base			
	BF470		–	–250	V
	BF472		–	–300	V
I <sub>CM</sub>	peak collector current		–	–100	mA
P <sub>tot</sub>	total power dissipation	T <sub>mb</sub> ≤ 114 °C	–	1.8	W
h <sub>FE</sub>	DC current gain	I <sub>C</sub> = –25 mA; V <sub>CE</sub> = –20 V	50	–	
C <sub>re</sub>	feedback capacitance	I <sub>C</sub> = i <sub>c</sub> = 0; V <sub>CE</sub> = –30 V; f = 1 MHz	–	1.8	pF
f <sub>T</sub>	transition frequency	I <sub>C</sub> = –10 mA; V <sub>CE</sub> = –10 V; f = 100 MHz	60	–	MHz

## PNP high-voltage transistors

## BF470; BF472

**LIMITING VALUES**

In accordance with the Absolute Maximum Rating System (IEC 134).

SYMBOL	PARAMETER	CONDITIONS	MIN.	MAX.	UNIT
V <sub>CBO</sub>	collector-base voltage	open emitter			
	BF470		–	–250	V
	BF472		–	–300	V
V <sub>CEO</sub>	collector-emitter voltage	open base			
	BF470		–	–250	V
	BF472		–	–300	V
V <sub>EBO</sub>	emitter-base voltage	open collector	–	–5	V
I <sub>C</sub>	collector current (DC)		–	–50	mA
I <sub>CM</sub>	peak collector current		–	–100	mA
I <sub>BM</sub>	peak base current		–	–50	mA
P <sub>tot</sub>	total power dissipation	T <sub>mb</sub> ≤ 114 °C	–	1.8	W
T <sub>stg</sub>	storage temperature		–65	+150	°C
T <sub>j</sub>	junction temperature		–	150	°C
T <sub>amb</sub>	operating ambient temperature		–65	+150	°C

**THERMAL CHARACTERISTICS**

SYMBOL	PARAMETER	CONDITIONS	VALUE	UNIT
R <sub>th j-a</sub>	thermal resistance from junction to ambient	in free air; note 1	100	K/W
R <sub>th j-mb</sub>	thermal resistance from junction to mounting base		20	K/W

**Note**

1. Transistor mounted on a printed-circuit board, maximum lead length 4 mm; mounting pad for collector lead minimum 10 × 10 mm.

**CHARACTERISTICS**

T<sub>j</sub> = 25 °C unless otherwise specified.

SYMBOL	PARAMETER	CONDITIONS	MIN.	MAX.	UNIT
I <sub>CBO</sub>	collector cut-off current	I <sub>E</sub> = 0; V <sub>CB</sub> = –200 V	–	–10	nA
		I <sub>E</sub> = 0; V <sub>CB</sub> = –200 V; T <sub>j</sub> = 150 °C	–	–10	μA
I <sub>EBO</sub>	emitter cut-off current	I <sub>C</sub> = 0; V <sub>EB</sub> = –5 V	–	–50	nA
h <sub>FE</sub>	DC current gain	I <sub>C</sub> = –25 mA; V <sub>CE</sub> = –20 V	50	–	
V <sub>CEsat</sub>	collector-emitter saturation voltage	I <sub>C</sub> = –30 mA; I <sub>B</sub> = –5 mA	–	–600	mV
C <sub>re</sub>	feedback capacitance	I <sub>C</sub> = I <sub>c</sub> = 0; V <sub>CE</sub> = –30 V; f = 1 MHz	–	1.8	pF
f <sub>T</sub>	transition frequency	I <sub>C</sub> = –10 mA; V <sub>CE</sub> = –10 V; f = 100 MHz	60	–	MHz

PNP high-voltage transistors

BF470; BF472

PACKAGE OUTLINE

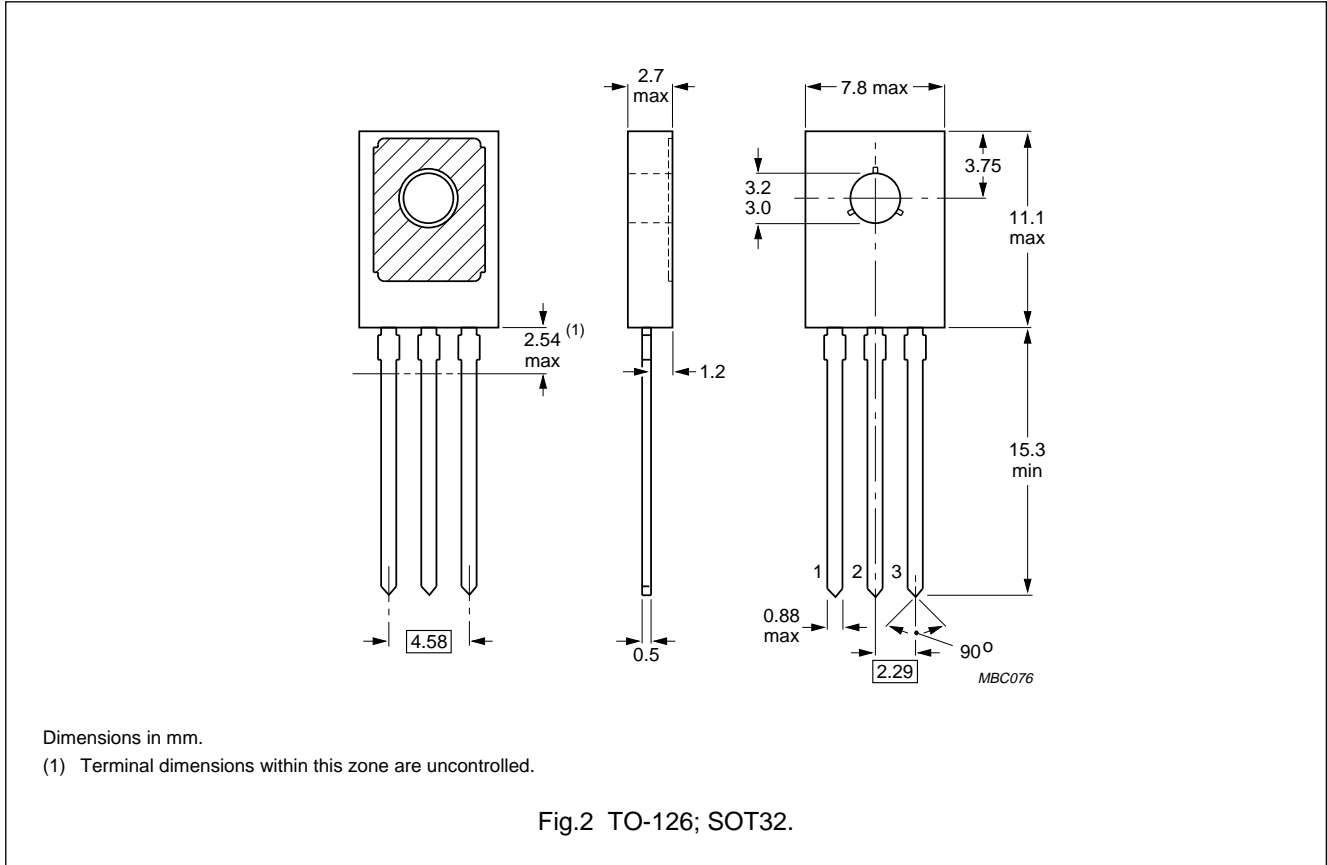

DEFINITIONS

<b>Data sheet status</b>	
Objective specification	This data sheet contains target or goal specifications for product development.
Preliminary specification	This data sheet contains preliminary data; supplementary data may be published later.
Product specification	This data sheet contains final product specifications.
<b>Limiting values</b>	
Limiting values given are in accordance with the Absolute Maximum Rating System (IEC 134). Stress above one or more of the limiting values may cause permanent damage to the device. These are stress ratings only and operation of the device at these or at any other conditions above those given in the Characteristics sections of the specification is not implied. Exposure to limiting values for extended periods may affect device reliability.	
<b>Application information</b>	
Where application information is given, it is advisory and does not form part of the specification.	

LIFE SUPPORT APPLICATIONS

These products are not designed for use in life support appliances, devices, or systems where malfunction of these products can reasonably be expected to result in personal injury. Philips customers using or selling these products for use in such applications do so at their own risk and agree to fully indemnify Philips for any damages resulting from such improper use or sale.