

FAST SWITCHING DARLINGTON TRANSISTORS

DESCRIPTION

The BU806/807 and BU806FI/807FI are silicon epitaxial planar NPN power transistors in Darlington configuration with integrated base-emitter speed-up diode, mounted respectively in TO-220 plastic package and ISOWATT220 fully isolated package. They are high voltage, high current devices for fast switching applications. In particular they can be used in horizontal output stages of 110° CRT video displays. The BU806/FI are primarily intended for large screen, while the BU807/FI are for medium and small screens.

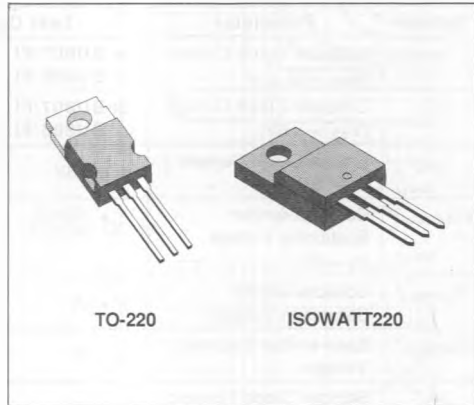

INTERNAL SCHEMATIC DIAGRAM

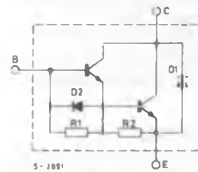

ABSOLUTE MAXIMUM RATINGS

Symbol	Parameter	BU806/FI	BU807/FI	Unit
V_{CBO}	Collector-base Voltage ($I_E = 0$)	400	330	V
V_{CEV}	Collector-emitter Voltage ($V_{BE} = -6V$)	400	330	V
V_{CEO}	Collector-emitter Voltage ($I_B = 0$)	200	150	V
V_{EBO}	Emitter-base Voltage ($I_C = 0$)	6		V
I_C	Collector Current	8		A
I_{CM}	Collector Peak Current	15		A
I_{DM}	Damper Diode Peak Forward Current	10		A
I_B	Base Current	2		A
		TO-220	ISOWATT220	
P_{tot}	Total Power Dissipation at $T_c < 25^\circ C$	60	30	W
T_{stg}	Storage Temperature	- 65 to 150		$^\circ C$
T_j	Max. Operating Junction Temperature	150		$^\circ C$

THERMAL DATA

			TO-220	ISOWATT220	
$R_{thj-case}$	Thermal Resistance Junction-case	Max	2.08	4.16	$^{\circ}C/W$
$R_{thj-amb}$	Thermal Resistance Junction-ambient	Max	70		$^{\circ}C/W$

ELECTRICAL CHARACTERISTICS ($T_{case} = 25^{\circ}C$ unless otherwise specified)

Symbol	Parameter	Test Conditions		Min.	Typ.	Max.	Unit
I_{CES}	Collector Cutoff Current ($V_{BE} = 0$)	for BU807/FI for BU806/FI	$V_{CE} = 330V$ $V_{CE} = 400V$			100 100	μA μA
I_{CEV}	Collector Cutoff Current ($V_{BE} = -6V$)	for BU807/FI for BU806/FI	$V_{CE} = 330V$ $V_{CE} = 400V$			100 100	μA μA
I_{EBO}	Emitter Cutoff Current ($I_C = 0$)	$V_{EB} = 6V$				3.5	mA
$V_{CEO(sus)}^*$	Collector-emitter Sustaining Voltage ($I_B = 0$)	$I_C = 100mA$	for BU807/FI for BU806/FI	150 200			V V
$V_{CE(sat)}^*$	Collector-emitter Saturation Voltage	$I_C = 5A$	$I_B = 50mA$			1.5	V
$V_{BE(sat)}^*$	Base-emitter Saturation Voltage	$I_C = 5A$	$I_B = 50mA$			2.4	V
V_F^*	Damper Diode Forward Voltage	$I_F = 4A$				2	V
t_{off}^{**}	Turn-off Time	$I_C = 5A$	$I_{B1} = 50mA$		0.4	1	μs
t_{on}	Turn-on Time	RESISTIVE LOAD			0.35		μs
t_s	Storage Time	$I_C = 5A$	$I_{B1} = 50mA$		0.55		μs
t_f	Fall Time	$I_{B2} = -500mA$	$V_{CC} = 100V$		0.2		μs

* Pulsed : pulse duration = 300 μs , duty cycle = 1.5 %.

** See Test Circuit.

Safe Operating Areas.

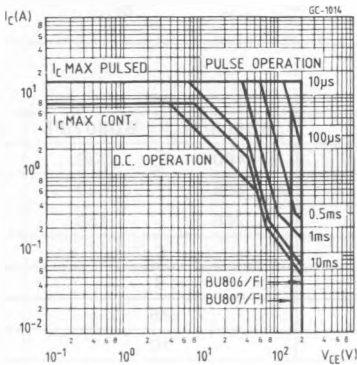

DC Current Gain.

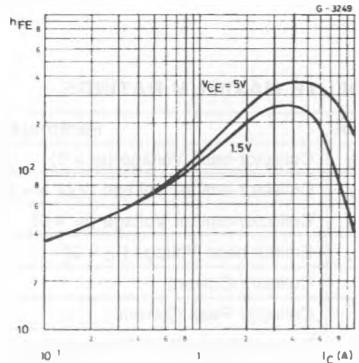

Collector-emitter Saturation Voltage.

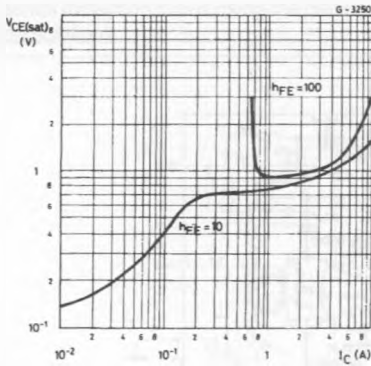

Collector-emitter Saturation Voltage.

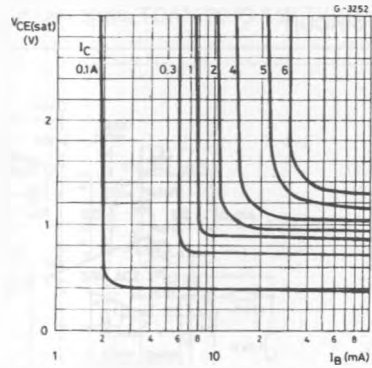

Base-emitter Saturation Voltage.

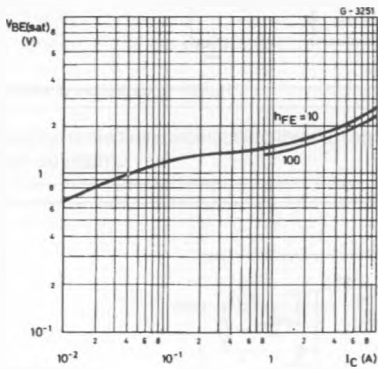

Damper Diode.

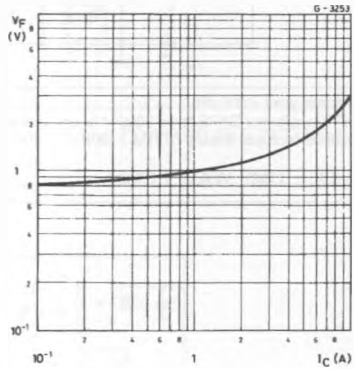

Saturated Switching Characteristics (resistive load).

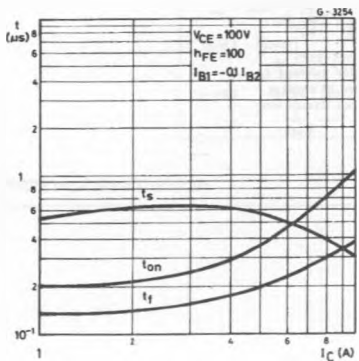

Saturated Switching Characteristics (inductive load).

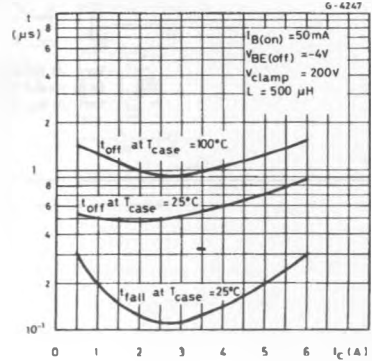

HORIZONTAL DEFLECTION TURN-OFF TIME

TEST CIRCUIT

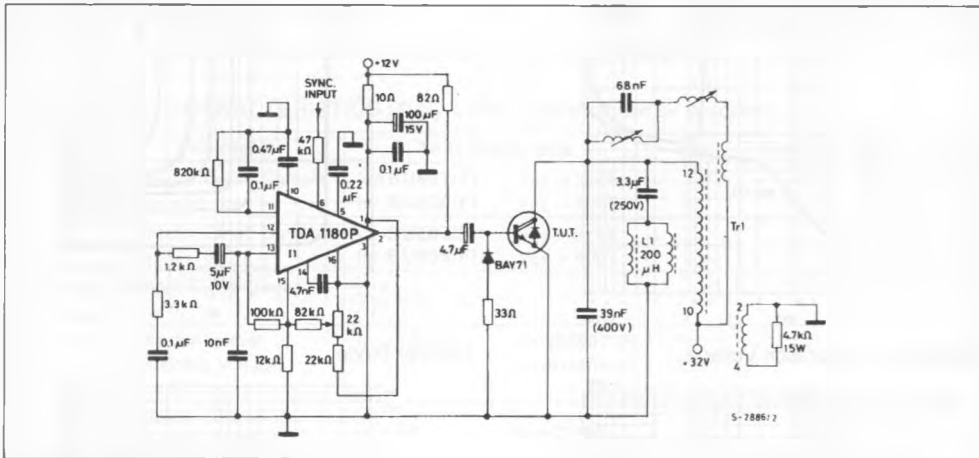

L1 = Horizontal yoke = 200 μH
 Tr1 = EHT Transformer SAREAtype 900914 or equivalent.
 I1 = Horizontal oscillator linear I. C. TDA 1180P.

TURN-OFF TIME WAVEFORM

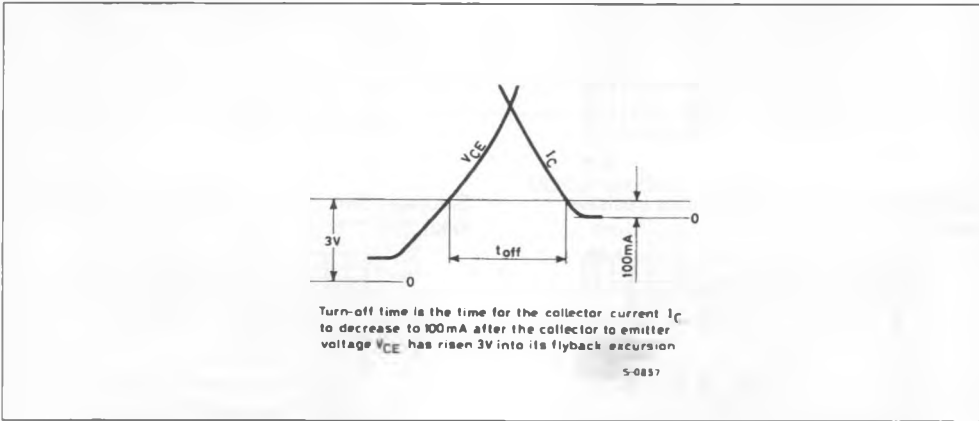

APPLICATION INFORMATION

Horizontal deflection circuit using the darlington BU806 directly driven by the TDA1180 (B & W TV set : large screen solution).

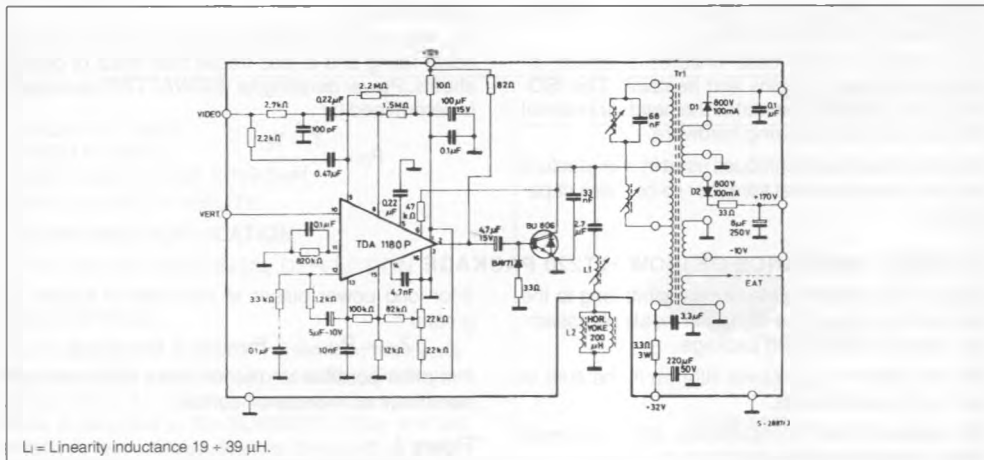

Horizontal deflection circuit using the darlington BU807 directly driven by the TDA1180 (B & W TV set : small screen solution).

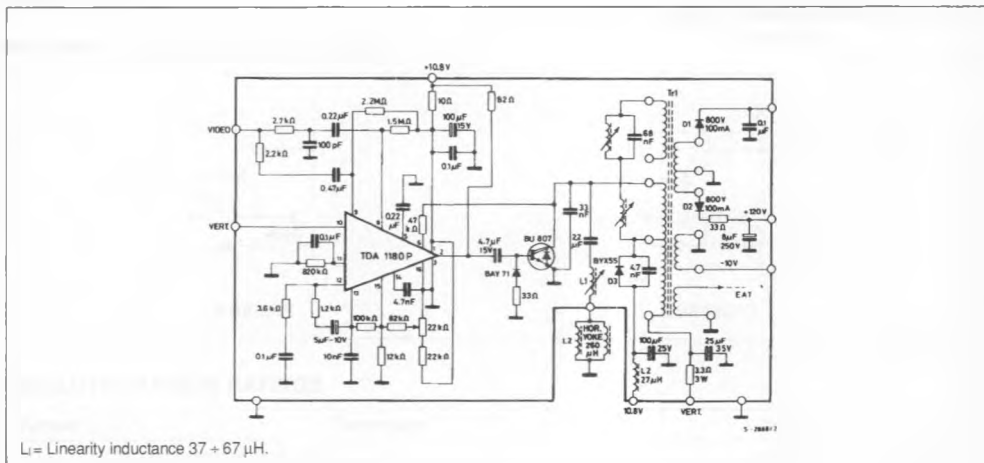

ISOWATT220 PACKAGE CHARACTERISTICS AND APPLICATION

ISOWATT220 is fully isolated to 2000V dc. Its thermal impedance, given in the data sheet, is optimised to give efficient thermal conduction together with excellent electrical isolation.

The structure of the case ensures optimum distances between the pins and heatsink. The ISOWATT220 package eliminates the need for external isolation so reducing fixing hardware.

Accurate moulding techniques used in manufacture assures consistent heat spreader-to-heatsink capacitance.

ISOWATT220 thermal performance is equivalent to that of the standard part, mounted with a 0.1 mm mica washer.

The thermally conductive plastic has a higher break-down rating and is less fragile than mica or plastic sheets. Power derating for ISOWATT220 packages is determined by :

$$P_D = \frac{T_J - T_c}{R_{th}}$$

THERMAL IMPEDANCE OF ISOWATT220 PACKAGE

Figure 1 illustrates the elements contributing to the thermal resistance of a transistor heatsink assembly, using ISOWATT220 package.

The total thermal resistance $R_{th}(tot)$ is the sum of each of these elements.

The transient thermal impedance, Z_{th} for different pulse durations can be estimated as follows :

- 1-for a short duration power pulse less than 1ms :
 $Z_{th} < R_{thJ-C}$
- 2-for an intermediate power pulse of 5ms to 50ms :
 $Z_{th} = R_{thJ-C}$

3-for long power pulses of the order of 500ms or greater :

$$Z_{th} = R_{thJ-C} + R_{thC-HS} + R_{thHS-amb}$$

It is often possible to discern these areas on transient thermal impedance curves.

Figure 1.

