

HIGH CURRENT, HIGH SPEED, HIGH POWER TRANSISTOR

DESCRIPTION

The BUX22 is a silicon multiepitaxial planar NPN transistor in modified Jedec TO-3 metal case, intended for use in switching and linear applications in military and industrial equipment.

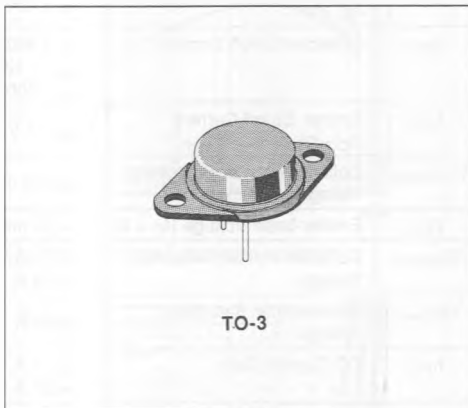

TO-3

INTERNAL SCHEMATIC DIAGRAM

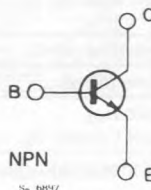

ABSOLUTE MAXIMUM RATINGS

Symbol	Parameter	Value	Unit
V_{CBO}	Collector-base Voltage ($I_E = 0$)	300	V
V_{CEX}	Collector-emitter Voltage ($V_{BE} = -1.5$ V)	300	V
V_{CEO}	Collector-emitter Voltage ($I_B = 0$)	250	V
V_{EBO}	Emitter-base Voltage ($I_C = 0$)	7	V
I_C	Collector Current	40	A
I_{CM}	Collector Peak Current ($t_p = 10$ ms)	50	A
I_B	Base Current	8	A
P_{Tot}	Total Power Dissipation at $T_{case} \leq 25$ °C	350	W
T_{stg}	Storage Temperature	- 65 to 200	°C
T_j	Junction Temperature	200	°C

THERMAL DATA

$R_{th\ j-case}$	Thermal Resistance Junction-case	Max	0.5	$^{\circ}C/W$
------------------	----------------------------------	-----	-----	---------------

ELECTRICAL CHARACTERISTICS ($T_{case} = 25\ ^{\circ}C$ unless otherwise specified)

Symbol	Parameter	Test Conditions	Min.	Typ.	Max.	Unit
I_{CEO}	Collector Cutoff Current ($I_B = 0$)	$V_{CE} = 200\ V$			3	mA
I_{CEX}	Collector Cutoff Current	$V_{CE} = 300\ V$ $V_{BE} = -1.5\ V$ $T_{case} = 125\ ^{\circ}C$ $V_{CE} = 300\ V$ $V_{BE} = -1.5\ V$			3	mA
I_{EBO}	Emitter Cutoff Current ($I_C = 0$)	$V_{EB} = 5\ V$			1	mA
$V_{CEO(sus)}$ *	Collector-emitter Sustaining Voltage	$I_C = 200\ mA$	250			V
V_{EBO}	Emitter-base Voltage ($I_C = 0$)	$I_E = 50\ mA$	7			V
$V_{CE(sat)}$ *	Collector-emitter Saturation Voltage	$I_C = 10\ A$ $I_S = 1\ A$ $I_C = 20\ A$ $I_B = 2.5\ A$		0.2 0.32	1 1.5	V V
$V_{BE(sat)}$ *	Base-emitter Saturation Voltage	$I_C = 20\ A$ $I_B = 2.5\ A$		1.1	1.5	V
h_{FE} *	DC Current Gain	$I_C = 10\ A$ $V_{CE} = 4\ V$ $I_C = 20\ A$ $V_{CE} = 4\ V$	20 10		60	
$I_{s/b}$	Second Breakdown Collector Current	$V_{CE} = 140\ V$ $t = 1\ s$ $V_{CE} = 20\ V$ $t = 1\ s$	0.15 17.5			A A
f_T	Transition Frequency	$I_C = 2\ A$ $V_{CE} = 15\ V$ $f = 10\ MHz$	10			MHz
t_{on}	Turn-on Time (fig. 2)	$I_C = 20\ A$ $I_{B1} = 2.5\ A$ $V_{CC} = 100\ V$		0.22	1.3	μs
t_s	Storage Time (fig. 2)	$I_C = 20\ A$ $I_{B1} = 2.5\ A$		1.5	2	μs
t_f	Fall Time (fig. 2)	$I_{B2} = -2.5\ A$ $V_{CC} = 100\ V$		0.17	0.5	μs
	Clamped $E_{s/b}$ Collector Current (fig. 1)	$V_{clamp} = 250\ V$ $L = 500\ \mu H$	25			A

* Pulsed : pulse duration = 300 μs , duty cycle $\leq 2\ %$.

Safe Operating Areas.

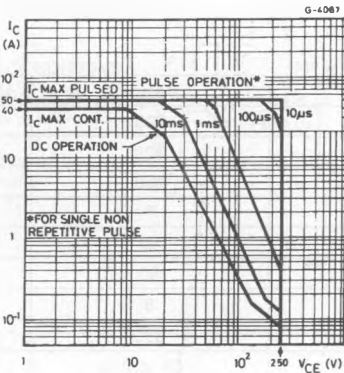

Derating Curves.

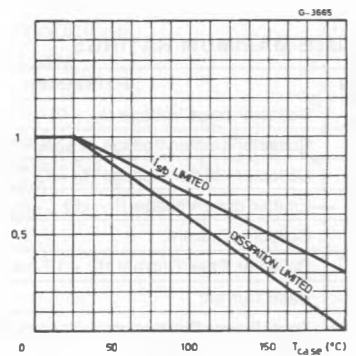

Thermal Transient Response.

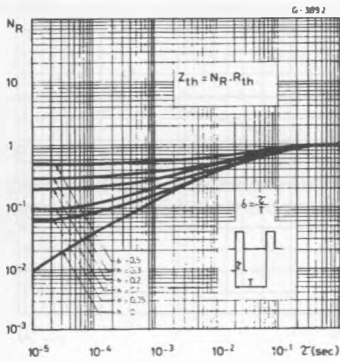

DC Current Gain.

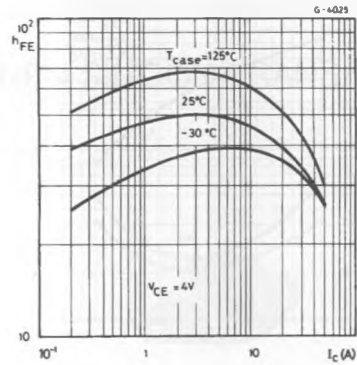

Collector-emitter Saturation Voltage.

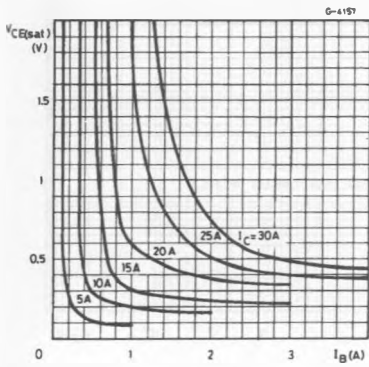

Collector-emitter Saturation Voltage.

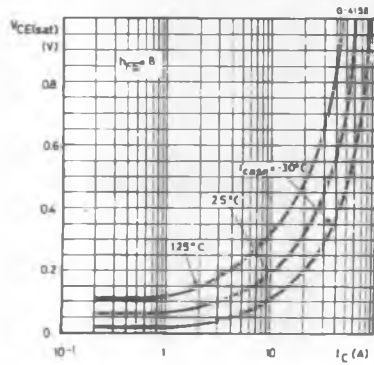

Base-emitter Saturation Voltage.

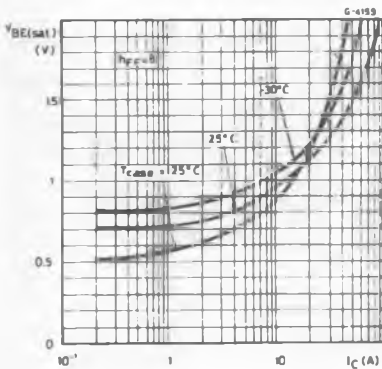

Saturated Switching Characteristics.

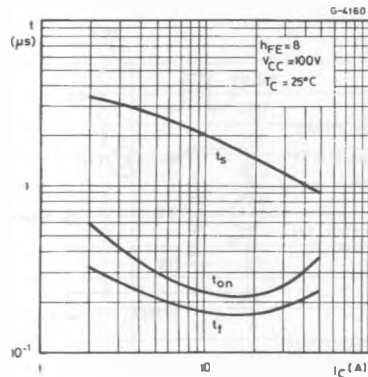

Saturated Switching Characteristics.

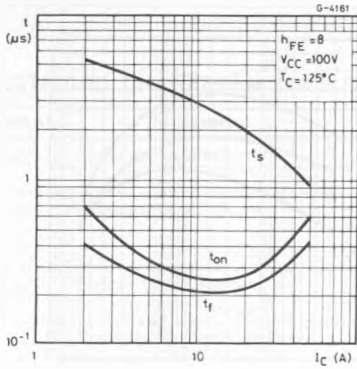

Transition Frequency.

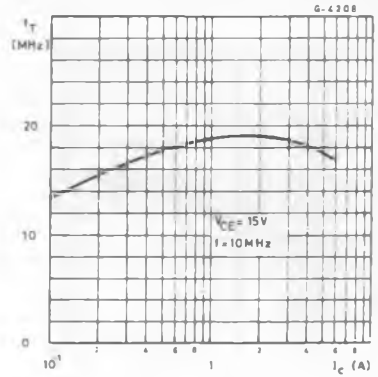

Collector-base Capacitance.

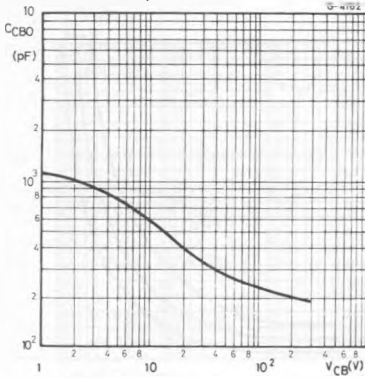

Clamped Reverse Bias Safe Operating Areas.

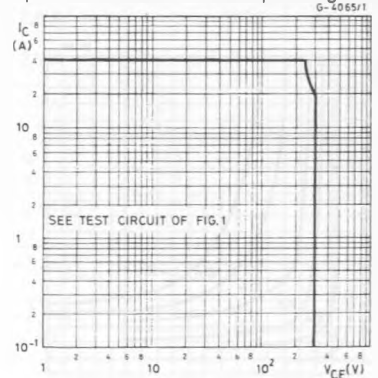

Figure 1 : Clamped $E_{S/b}$ Test Circuit.

Figure 2 : Switching Times Test Circuit (resistive load).

