

**CMPT2907AE**  
**ENHANCED SPECIFICATION**  
**SURFACE MOUNT**  
**PNP SILICON TRANSISTOR**

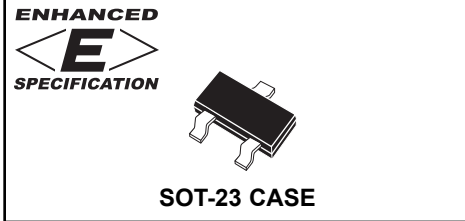

# Central<sup>TM</sup>

## Semiconductor Corp.

**DESCRIPTION:**

The Central Semiconductor CMPT2907AE is an Enhanced version of the CMPT2907A PNP Switching transistor in a SOT-23 surface mount package, designed for switching applications, interface circuit and driver circuit applications.

**MARKING CODE: C2FE**

**FEATURED ENHANCED SPECIFICATIONS:**

- ◆  $BV_{CBO}$  from 60V min to 90V min. (115V TYP)
- ◆  $V_{CE(SAT)}$  from 1.6V max to 0.7V max. (0.280V TYP)
- ◆  $h_{FE}$  from 50 min to 75 min. (110 TYP)

**MAXIMUM RATINGS:** ( $T_A=25^\circ\text{C}$ )

- ◆ **Collector-Base Voltage**  
Collector-Emitter Voltage
- Emitter-Base Voltage
- Collector Current
- Power Dissipation
- Operating and Storage  
Junction Temperature
- Thermal Resistance

SYMBOL	VALUES	UNITS
$V_{CBO}$	<b>90</b>	V
$V_{CEO}$	60	V
$V_{EBO}$	5.0	V
$I_C$	600	mA
$P_D$	350	mW
$T_J, T_{stg}$	-65 to +150	°C
$\Theta_{JA}$	357	°C/W

**ELECTRICAL CHARACTERISTICS:** ( $T_A=25^\circ\text{C}$  unless otherwise noted)

SYMBOL	TEST CONDITIONS	MIN	TYP	MAX	UNITS
$I_{CBO}$	$V_{CB}=50\text{V}$			10	nA
$I_{CBO}$	$V_{CB}=50\text{V}, T_A=125^\circ\text{C}$			10	μA
$I_{CEV}$	$V_{CE}=30\text{V}, V_{EB}=0.5\text{V}$			50	nA
◆ $BV_{CBO}$	<b><math>I_C=10\mu\text{A}</math></b>	<b>90</b>	<b>115</b>		<b>V</b>
$BV_{CEO}$	$I_C=10\text{mA}$	60			V
$BV_{EBO}$	$I_E=10\mu\text{A}$	5.0			V
◆ $V_{CE(SAT)}$	<b><math>I_C=150\text{mA}, I_B=15\text{mA}</math></b>		<b>0.103</b>	<b>0.2</b>	<b>V</b>
◆ $V_{CE(SAT)}$	<b><math>I_C=500\text{mA}, I_B=50\text{mA}</math></b>		<b>0.280</b>	<b>0.7</b>	<b>V</b>
$V_{BE(SAT)}$	$I_C=150\text{mA}, I_B=15\text{mA}$			1.3	V
$V_{BE(SAT)}$	$I_C=500\text{mA}, I_B=50\text{mA}$			2.6	V
◆ $h_{FE}$	<b><math>V_{CE}=10\text{V}, I_C=0.1\text{mA}</math></b>	<b>100</b>	<b>205</b>		
$h_{FE}$	$V_{CE}=10\text{V}, I_C=1.0\text{mA}$	100			
$h_{FE}$	$V_{CE}=10\text{V}, I_C=10\text{mA}$	100			
$h_{FE}$	$V_{CE}=10\text{V}, I_C=150\text{mA}$	100		300	
◆ $h_{FE}$	<b><math>V_{CE}=10\text{V}, I_C=500\text{mA}</math></b>	<b>75</b>	<b>110</b>		
$f_T$	$V_{CE}=20\text{V}, I_C=50\text{mA}, f=100\text{MHz}$	200			MHz
$C_{ob}$	$V_{CB}=10\text{V}, I_E=0, f=1.0\text{MHz}$			8.0	pF
$C_{ib}$	$V_{BE}=2.0\text{V}, I_C=0, f=1.0\text{MHz}$			30	pF

- ◆ Enhanced specification.

R1 (20-February 2003)

SURFACE MOUNT  
PNP SILICON TRANSISTOR

ELECTRICAL CHARACTERISTICS: ( $T_A=25^\circ\text{C}$  unless otherwise noted)

SYMBOL	TEST CONDITIONS	MIN	TYP	MAX	UNITS
$t_{on}$	$V_{CC}=30\text{V}$ , $V_{BE}=0.5\text{V}$ , $I_C=150\text{mA}$ , $I_{B1}=15\text{mA}$			45	ns
$t_d$	$V_{CC}=30\text{V}$ , $V_{BE}=0.5\text{V}$ , $I_C=150\text{mA}$ , $I_{B1}=15\text{mA}$			10	ns
$t_r$	$V_{CC}=30\text{V}$ , $V_{BE}=0.5\text{V}$ , $I_C=150\text{mA}$ , $I_{B1}=15\text{mA}$			40	ns
$t_{off}$	$V_{CC}=6.0\text{V}$ , $I_C=150\text{mA}$ , $I_{B1}=I_{B2}=15\text{mA}$			100	ns
$t_s$	$V_{CC}=6.0\text{V}$ , $I_C=150\text{mA}$ , $I_{B1}=I_{B2}=15\text{mA}$			80	ns
$t_f$	$V_{CC}=6.0\text{V}$ , $I_C=150\text{mA}$ , $I_{B1}=I_{B2}=15\text{mA}$			30	ns

SOT-23 CASE - MECHANICAL OUTLINE

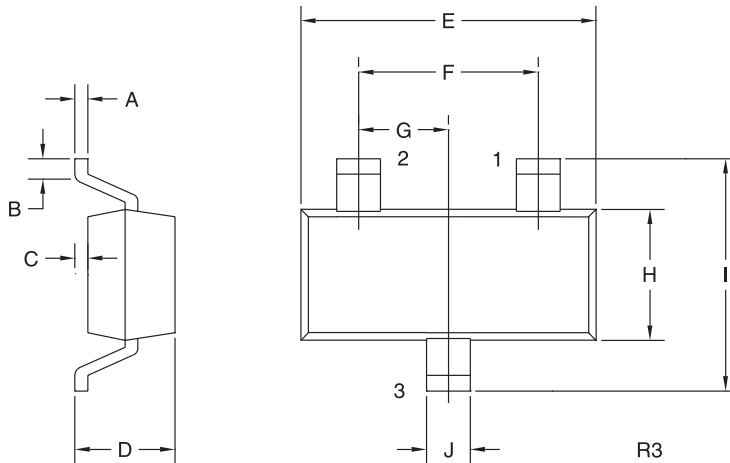

LEAD CODE:

- 1) BASE
- 2) EMITTER
- 3) COLLECTOR

MARKING CODE: C2FE

SYMBOL	DIMENSIONS			
	INCHES		MILLIMETERS	
	MIN	MAX	MIN	MAX
A	0.003	0.007	0.08	0.18
B	0.006	-	0.15	-
C	-	0.005	-	0.13
D	0.035	0.043	0.89	1.09
E	0.110	0.120	2.80	3.05
F	0.075		1.90	
G	0.037		0.95	
H	0.047	0.055	1.19	1.40
I	0.083	0.098	2.10	2.49
J	0.014	0.020	0.35	0.50

SOT-23 (REV: R3)