

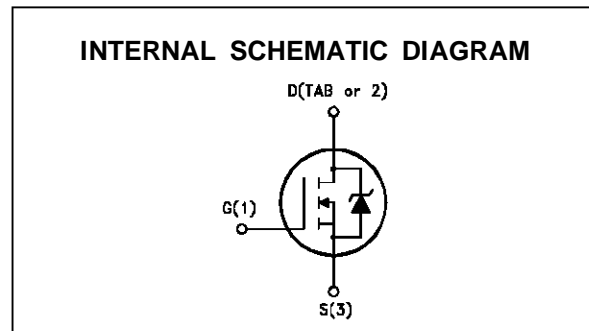
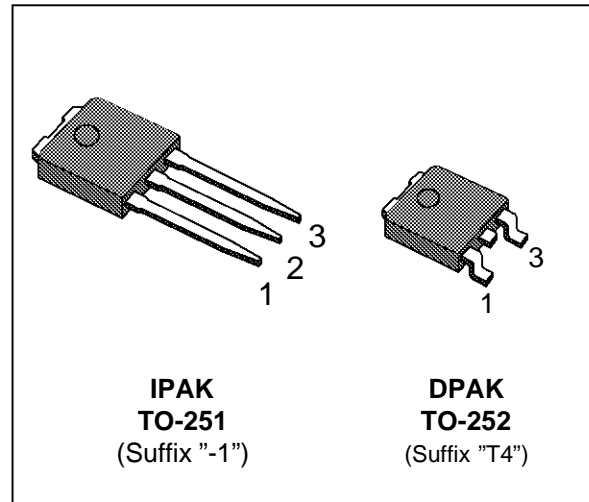
## N - CHANNEL ENHANCEMENT MODE POWER MOS TRANSISTOR

| TYPE    | V <sub>DSS</sub> | R <sub>DS(on)</sub> | I <sub>D</sub> |
|---------|------------------|---------------------|----------------|
| STD3N25 | 250 V            | < 2 Ω               | 3 A            |

- TYPICAL R<sub>DS(on)</sub> = 1 Ω
- AVALANCHE RUGGED TECHNOLOGY
- 100% AVALANCHE TESTED
- REPETITIVE AVALANCHE DATA AT 100°C
- APPLICATION ORIENTED CHARACTERIZATION
- THROUGH-HOLE IPAK (TO-251) POWER PACKAGE IN TUBE (SUFFIX "-1")
- SURFACE-MOUNTING DPAK (TO-252) POWER PACKAGE IN TAPE & REEL (SUFFIX "T4")

### APPLICATIONS

- HIGH SPEED SWITCHING
- UNINTERRUPTIBLE POWER SUPPLY (UPS)
- MOTOR CONTROL, AUDIO AMPLIFIERS
- INDUSTRIAL ACTUATORS
- DC-DC & DC-AC CONVERTERS FOR TELECOM, INDUSTRIAL AND CONSUMER ENVIRONMENT
- PARTICULARLY SUITABLE FOR ELECTRONIC FLUORESCENT LAMP BALLASTS



### ABSOLUTE MAXIMUM RATINGS

| Symbol              | Parameter   | Value      | Unit |
|---------------------|---|------------|------|
| V <sub>DS</sub>     | Drain-source Voltage (V <sub>GS</sub> = 0)            | 250        | V    |
| V <sub>DGR</sub>    | Drain- gate Voltage (R <sub>GS</sub> = 20 kΩ)         | 250        | V    |
| V <sub>GS</sub>     | Gate-source Voltage                                   | ± 20       | V    |
| I <sub>D</sub>      | Drain Current (continuous) at T <sub>c</sub> = 25 °C  | 3          | A    |
| I <sub>D</sub>      | Drain Current (continuous) at T <sub>c</sub> = 100 °C | 1.9        | A    |
| I <sub>DM</sub> (●) | Drain Current (pulsed)                                | 12         | A    |
| P <sub>tot</sub>    | Total Dissipation at T <sub>c</sub> = 25 °C           | 45         | W    |
|                     | Derating Factor                                       | 0.36       | W/°C |
| T <sub>stg</sub>    | Storage Temperature                                   | -65 to 150 | °C   |
| T <sub>j</sub>      | Max. Operating Junction Temperature                   | 150        | °C   |

(●) Pulse width limited by safe operating area

## STD3N25

### THERMAL DATA

|                |  |     |      |               |
|----------------|--|-----|------|---------------|
| $R_{thj-case}$ | Thermal Resistance Junction-case               | Max | 2.78 | $^{\circ}C/W$ |
| $R_{thj-amb}$  | Thermal Resistance Junction-ambient            | Max | 100  | $^{\circ}C/W$ |
| $R_{thc-sink}$ | Thermal Resistance Case-sink                   | Typ | 1.5  | $^{\circ}C/W$ |
| $T_l$          | Maximum Lead Temperature For Soldering Purpose |     | 275  | $^{\circ}C$   |

### AVALANCHE CHARACTERISTICS

| Symbol   | Parameter   | Max Value | Unit |
|----------|---|-----------|------|
| $I_{AR}$ | Avalanche Current, Repetitive or Not-Repetitive (pulse width limited by $T_j$ max, $\delta < 1\%$ )                         | 3         | A    |
| $E_{AS}$ | Single Pulse Avalanche Energy (starting $T_j = 25^{\circ}C$ , $I_D = I_{AR}$ , $V_{DD} = 50 V$ )                            | 20        | mJ   |
| $E_{AR}$ | Repetitive Avalanche Energy (pulse width limited by $T_j$ max, $\delta < 1\%$ )   | 5         | mJ   |
| $I_{AR}$ | Avalanche Current, Repetitive or Not-Repetitive ( $T_c = 100^{\circ}C$ , pulse width limited by $T_j$ max, $\delta < 1\%$ ) | 1.9       | A    |

### ELECTRICAL CHARACTERISTICS ( $T_{case} = 25^{\circ}C$ unless otherwise specified)

OFF

| Symbol        | Parameter  | Test Conditions  | Min. | Typ. | Max.        | Unit               |
|---------------|--|--|------|------|-------------|--------------------|
| $V_{(BR)DSS}$ | Drain-source Breakdown Voltage                   | $I_D = 250 \mu A$ $V_{GS} = 0$   | 250  |      |             | V                  |
| $I_{DSS}$     | Zero Gate Voltage Drain Current ( $V_{GS} = 0$ ) | $V_{DS} = \text{Max Rating}$<br>$V_{DS} = \text{Max Rating} \times 0.8$ $T_c = 125^{\circ}C$ |      |      | 250<br>1000 | $\mu A$<br>$\mu A$ |
| $I_{GSS}$     | Gate-body Leakage Current ( $V_{DS} = 0$ )       | $V_{GS} = \pm 20 V$  |      |      | $\pm 100$   | nA                 |

ON (\*)

| Symbol       | Parameter                         | Test Conditions   | Min. | Typ. | Max.   | Unit                 |
|--------------|-----------------------------------|---|------|------|--------|----------------------|
| $V_{GS(th)}$ | Gate Threshold Voltage            | $V_{DS} = V_{GS}$ $I_D = 250 \mu A$   | 2    | 3    | 4      | V                    |
| $R_{DS(on)}$ | Static Drain-source On Resistance | $V_{GS} = 10V$ $I_D = 1.5 A$<br>$V_{GS} = 10V$ $I_D = 1.5 A$ $T_c = 100^{\circ}C$ |      | 1    | 2<br>4 | $\Omega$<br>$\Omega$ |
| $I_{D(on)}$  | On State Drain Current            | $V_{DS} > I_{D(on)} \times R_{DS(on)max}$<br>$V_{GS} = 10 V$                      | 3    |      |        | A                    |

### DYNAMIC

| Symbol       | Parameter                    | Test Conditions   | Min. | Typ. | Max. | Unit |
|--------------|------------------------------|---|------|------|------|------|
| $g_{fs} (*)$ | Forward Transconductance     | $V_{DS} > I_{D(on)} \times R_{DS(on)max}$ $I_D = 1.5 A$ | 1    | 1.8  |      | S    |
| $C_{iss}$    | Input Capacitance            | $V_{DS} = 25 V$ $f = 1 MHz$ $V_{GS} = 0$                |      | 370  | 500  | pF   |
| $C_{oss}$    | Output Capacitance           |   |      | 60   | 100  | pF   |
| $C_{rss}$    | Reverse Transfer Capacitance |   |      | 10   | 20   | pF   |

**ELECTRICAL CHARACTERISTICS** (continued)

**SWITCHING ON**

| Symbol                        | Parameter  | Test Conditions   | Min. | Typ.         | Max.     | Unit           |
|-------------------------------|--|---|------|--------------|----------|----------------|
| $t_{d(on)}$<br>$t_r$          | Turn-on Time<br>Rise Time                                    | $V_{DD} = 125\text{ V}$ $I_D = 1.5\text{ A}$<br>$R_G = 50\ \Omega$ $V_{GS} = 10\text{ V}$<br>(see test circuit, figure 3) |      | 15<br>45     | 25<br>65 | ns<br>ns       |
| $(di/dt)_{on}$                | Turn-on Current Slope  | $V_{DD} = 200\text{ V}$ $I_D = 3\text{ A}$<br>$R_G = 50\ \Omega$ $V_{GS} = 10\text{ V}$<br>(see test circuit, figure 5)   |      | 180          |          | A/ $\mu$ s     |
| $Q_g$<br>$Q_{gs}$<br>$Q_{gd}$ | Total Gate Charge<br>Gate-Source Charge<br>Gate-Drain Charge | $V_{DD} = 200\text{ V}$ $I_D = 3\text{ A}$ $V_{GS} = 10\text{ V}$   |      | 16<br>5<br>6 | 25       | nC<br>nC<br>nC |

**SWITCHING OFF**

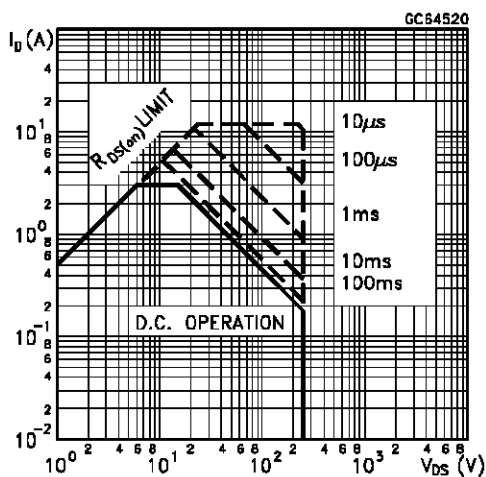
| Symbol                          | Parameter   | Test Conditions   | Min. | Typ.           | Max.           | Unit           |
|---------------------------------|---|---|------|----------------|----------------|----------------|
| $t_{r(Voff)}$<br>$t_f$<br>$t_c$ | Off-voltage Rise Time<br>Fall Time<br>Cross-over Time | $V_{DD} = 200\text{ V}$ $I_D = 3\text{ A}$<br>$R_G = 50\ \Omega$ $V_{GS} = 10\text{ V}$<br>(see test circuit, figure 5) |      | 15<br>15<br>35 | 25<br>25<br>55 | ns<br>ns<br>ns |

**SOURCE DRAIN DIODE**

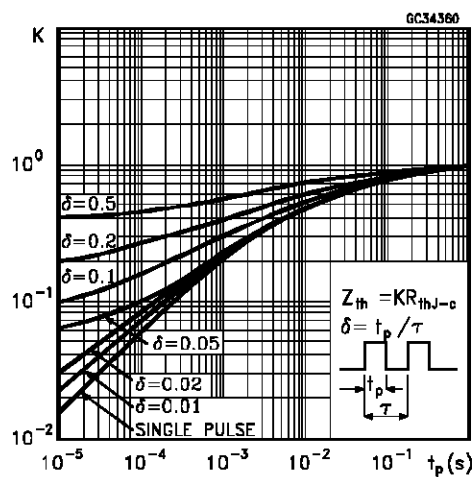
| Symbol                            | Parameter  | Test Conditions   | Min. | Typ.             | Max.    | Unit               |
|-----------------------------------|--|---|------|------------------|---------|--------------------|
| $I_{SD}$<br>$I_{SDM}(\bullet)$    | Source-drain Current<br>Source-drain Current (pulsed)                        |   |      |                  | 3<br>12 | A<br>A             |
| $V_{SD} (*)$                      | Forward On Voltage   | $I_{SD} = 3\text{ A}$ $V_{GS} = 0$  |      |                  | 1.5     | V                  |
| $t_{rr}$<br>$Q_{rr}$<br>$I_{RRM}$ | Reverse Recovery Time<br>Reverse Recovery Charge<br>Reverse Recovery Current | $I_{SD} = 3\text{ A}$ $di/dt = 100\text{ A}/\mu\text{s}$<br>$V_{DD} = 100\text{ V}$ $T_j = 150\text{ }^\circ\text{C}$<br>(see test circuit, figure 5) |      | 180<br>1.2<br>13 |         | ns<br>$\mu$ C<br>A |

(\*) Pulsed: Pulse duration = 300  $\mu$ s, duty cycle 1.5 %  
 (•) Pulse width limited by safe operating area

**Safe Operating Area**

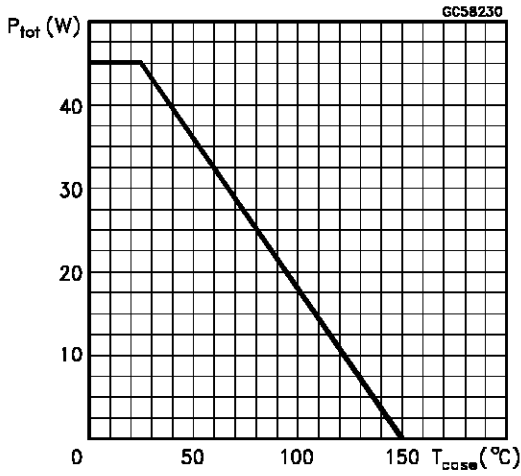


**Thermal Impedance**

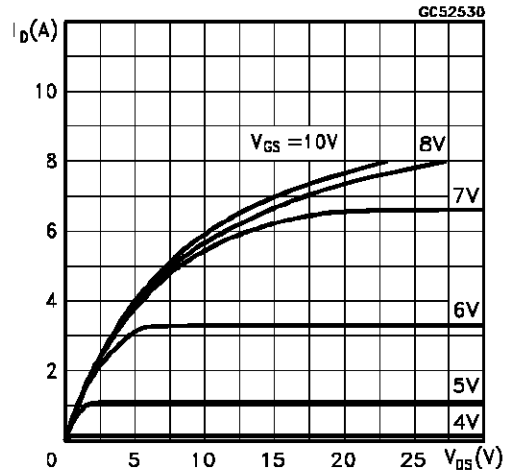


# STD3N25

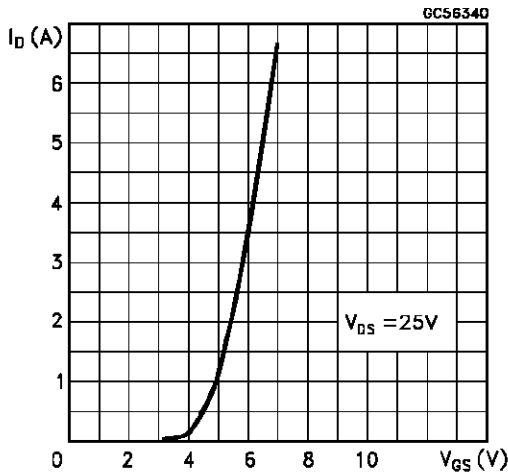
Derating Curve



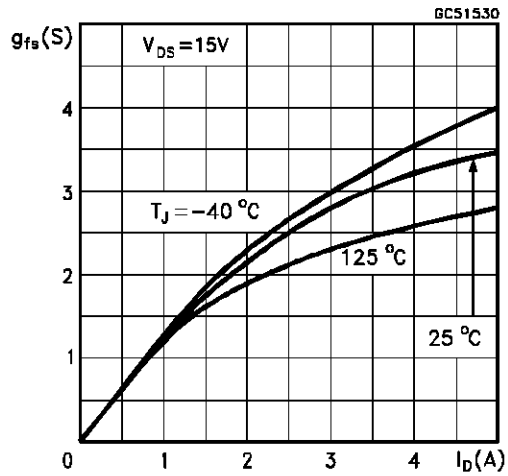
Output Characteristics



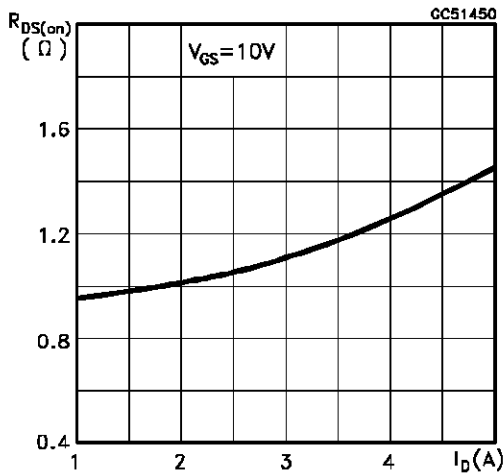
Transfer Characteristics



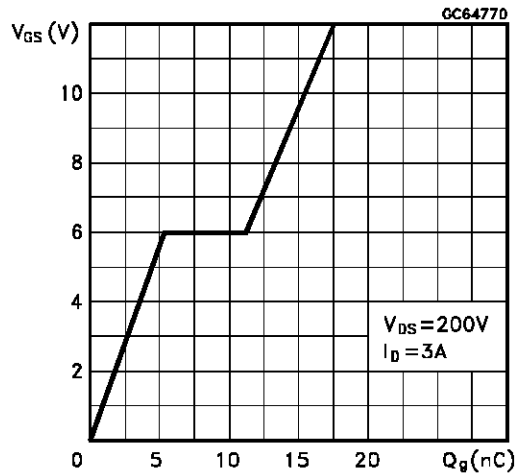
Transconductance



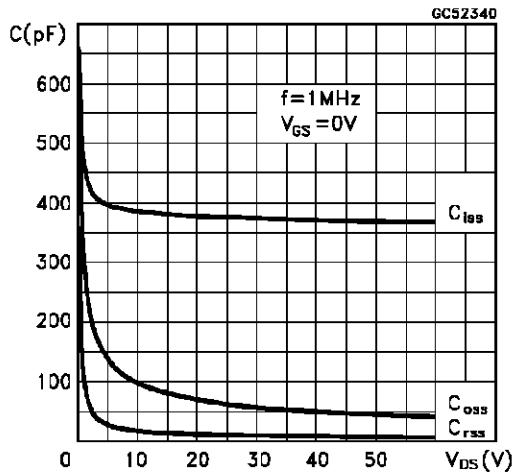
Static Drain-source On Resistance



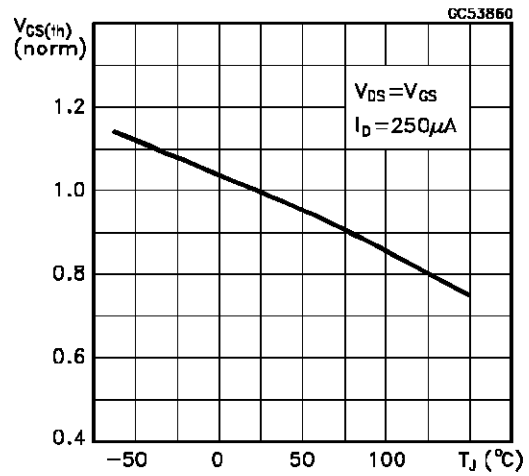
Gate Charge vs Gate-source Voltage



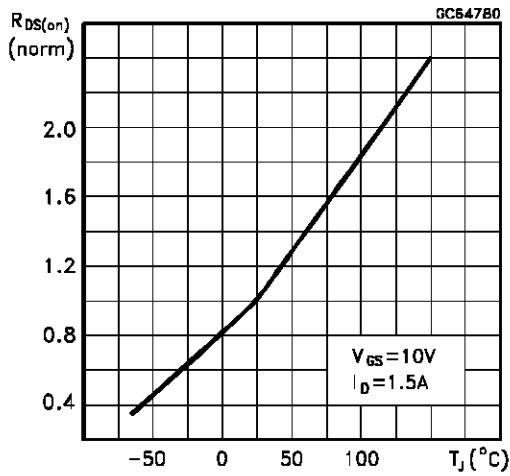
Capacitance Variations



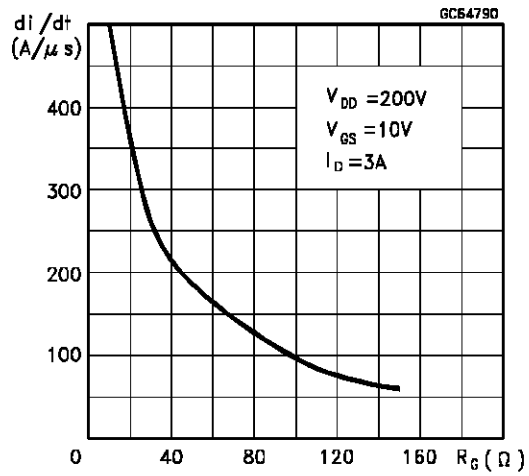
Normalized Gate Threshold Voltage vs Temperature



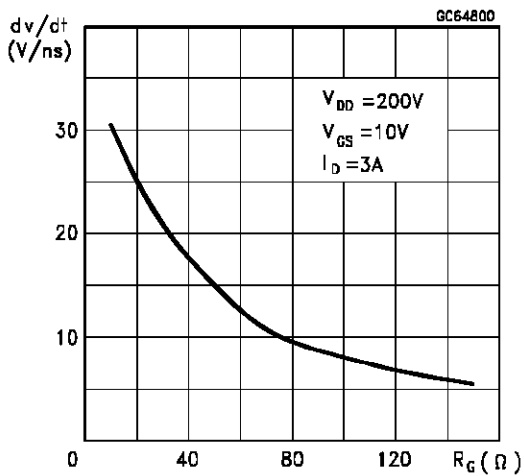
Normalized On Resistance vs Temperature



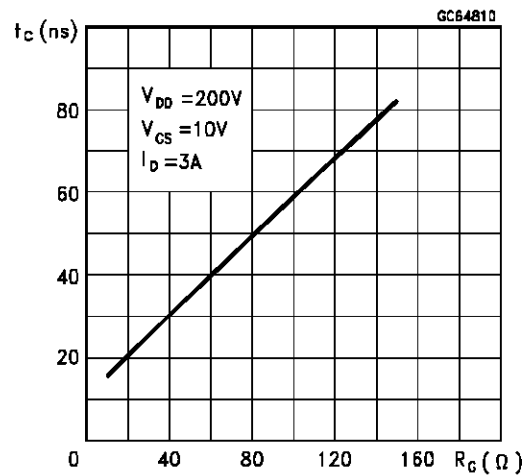
Turn-on Current Slope



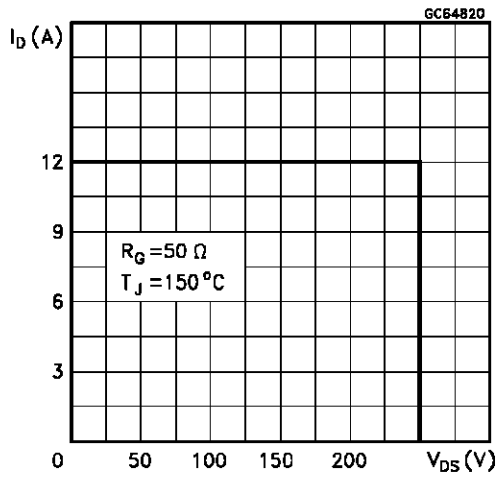
Turn-off Drain-source Voltage Slope



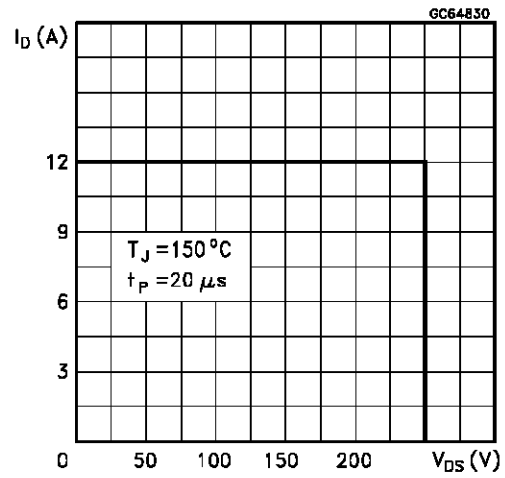
Cross-over Time



Switching Safe Operating Area



Accidental Overload Area



Source-drain Diode Forward Characteristics

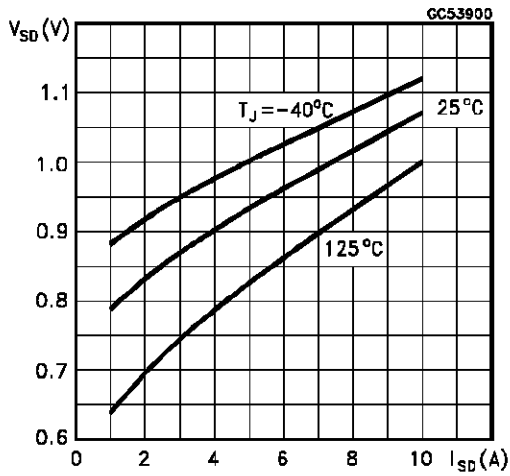
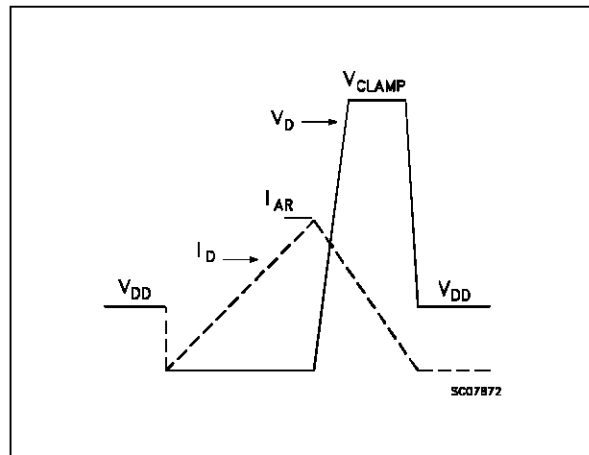
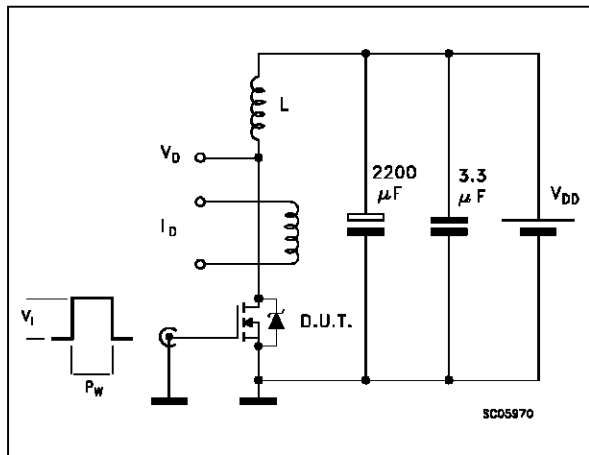
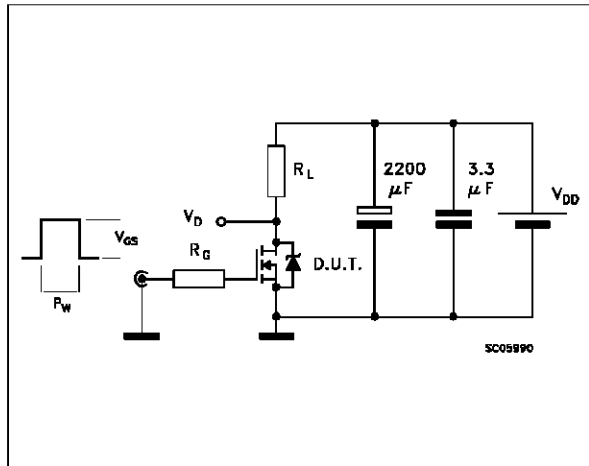


Fig. 1: Unclamped Inductive Load Test Circuits

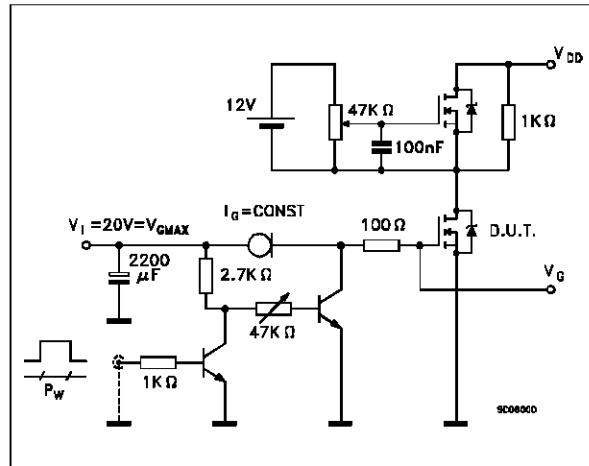
Fig. 2: Unclamped Inductive Waveforms



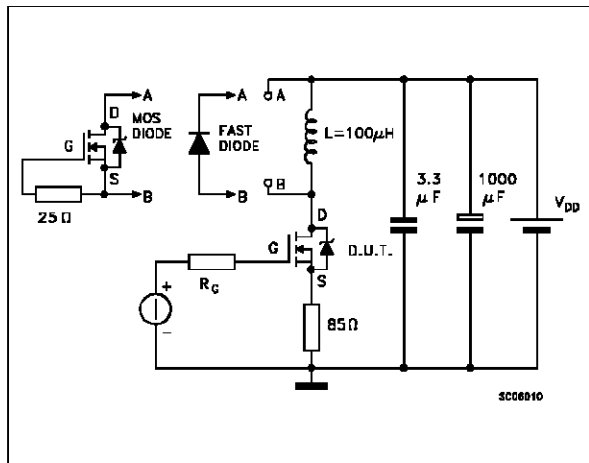
**Fig. 3:** Switching Times Test Circuits For Resistive Load



**Fig. 4:** Gate Charge Test Circuit

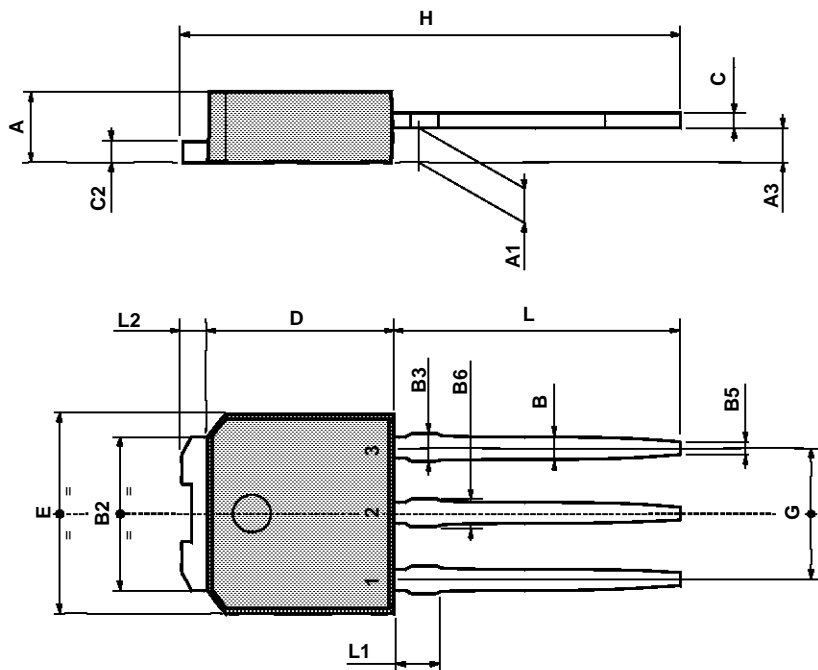


**Fig. 5:** Test Circuit For Inductive Load Switching And Diode Recovery Times



TO-251 (IPAK) MECHANICAL DATA

| DIM. | mm   |      |      | inch  |       |       |
|------|------|------|------|-------|-------|-------|
|      | MIN. | TYP. | MAX. | MIN.  | TYP.  | MAX.  |
| A    | 2.2  |      | 2.4  | 0.086 |       | 0.094 |
| A1   | 0.9  |      | 1.1  | 0.035 |       | 0.043 |
| A3   | 0.7  |      | 1.3  | 0.027 |       | 0.051 |
| B    | 0.64 |      | 0.9  | 0.025 |       | 0.031 |
| B2   | 5.2  |      | 5.4  | 0.204 |       | 0.212 |
| B3   |      |      | 0.85 |       |       | 0.033 |
| B5   |      | 0.3  |      |       | 0.012 |       |
| B6   |      |      | 0.95 |       |       | 0.037 |
| C    | 0.45 |      | 0.6  | 0.017 |       | 0.023 |
| C2   | 0.48 |      | 0.6  | 0.019 |       | 0.023 |
| D    | 6    |      | 6.2  | 0.236 |       | 0.244 |
| E    | 6.4  |      | 6.6  | 0.252 |       | 0.260 |
| G    | 4.4  |      | 4.6  | 0.173 |       | 0.181 |
| H    | 15.9 |      | 16.3 | 0.626 |       | 0.641 |
| L    | 9    |      | 9.4  | 0.354 |       | 0.370 |
| L1   | 0.8  |      | 1.2  | 0.031 |       | 0.047 |
| L2   |      | 0.8  | 1    |       | 0.031 | 0.039 |

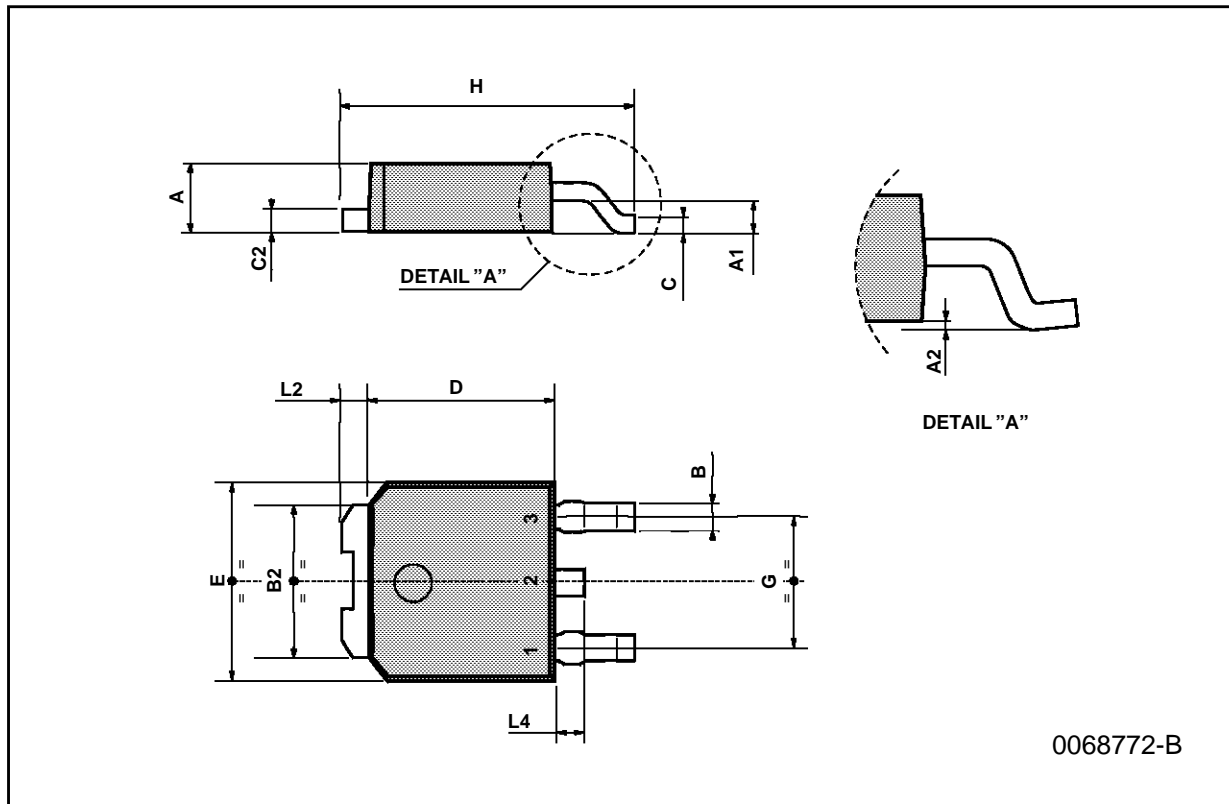


0068771-E



**TO-252 (DPAK) MECHANICAL DATA**

| DIM. | mm   |      |      | inch  |       |       |
|------|------|------|------|-------|-------|-------|
|      | MIN. | TYP. | MAX. | MIN.  | TYP.  | MAX.  |
| A    | 2.2  |      | 2.4  | 0.086 |       | 0.094 |
| A1   | 0.9  |      | 1.1  | 0.035 |       | 0.043 |
| A2   | 0.03 |      | 0.23 | 0.001 |       | 0.009 |
| B    | 0.64 |      | 0.9  | 0.025 |       | 0.035 |
| B2   | 5.2  |      | 5.4  | 0.204 |       | 0.212 |
| C    | 0.45 |      | 0.6  | 0.017 |       | 0.023 |
| C2   | 0.48 |      | 0.6  | 0.019 |       | 0.023 |
| D    | 6    |      | 6.2  | 0.236 |       | 0.244 |
| E    | 6.4  |      | 6.6  | 0.252 |       | 0.260 |
| G    | 4.4  |      | 4.6  | 0.173 |       | 0.181 |
| H    | 9.35 |      | 10.1 | 0.368 |       | 0.397 |
| L2   |      | 0.8  |      |       | 0.031 |       |
| L4   | 0.6  |      | 1    | 0.023 |       | 0.039 |



0068772-B

Information furnished is believed to be accurate and reliable. However, SGS-THOMSON Microelectronics assumes no responsibility for the consequences of use of such information nor for any infringement of patents or other rights of third parties which may result from its use. No license is granted by implication or otherwise under any patent or patent rights of SGS-THOMSON Microelectronics. Specifications mentioned in this publication are subject to change without notice. This publication supersedes and replaces all information previously supplied. SGS-THOMSON Microelectronics products are not authorized for use as critical components in life support devices or systems without express written approval of SGS-THOMSON Microelectronics.

© 1994 SGS-THOMSON Microelectronics - All Rights Reserved

SGS-THOMSON Microelectronics GROUP OF COMPANIES  
Australia - Brazil - France - Germany - Hong Kong - Italy - Japan - Korea - Malaysia - Malta - Morocco - The Netherlands -  
Singapore - Spain - Sweden - Switzerland - Taiwan - Thailand - United Kingdom - U.S.A