

Silicon PNP Power Transistors

D45C4

DESCRIPTION

- Low Saturation Voltage
- Good Linearity of h_{FE}
- Fast Switching Speeds
- Complement to Type D44C4

APPLICATIONS

- Designed for various specific and general purpose application such as: output and driver stages of amplifiers operating at frequencies from DC to greater than 1.0MHz series, shunt and switching regulators; low and high frequency inverters/converters and many others.

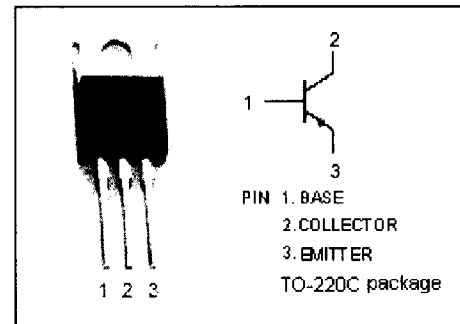

ABSOLUTE MAXIMUM RATINGS ($T_a=25^\circ\text{C}$)

SYMBOL	PARAMETER	VALUE	UNIT
V_{CES}	Collector-Emitter Voltage	-55	V
V_{CEO}	Collector-Emitter Voltage	-45	V
V_{EBO}	Emitter-Base Voltage	-5	V
I_C	Collector Current-Continuous	-4	A
I_{CM}	Collector Current-Peak	-6	A
I_B	Base Current-Continuous	-1	A
P_C	Collector Power Dissipation @ $T_c=25^\circ\text{C}$	30	W
T_j	Junction Temperature	150	$^\circ\text{C}$
T_{stg}	Storage Temperature Range	-55~150	$^\circ\text{C}$

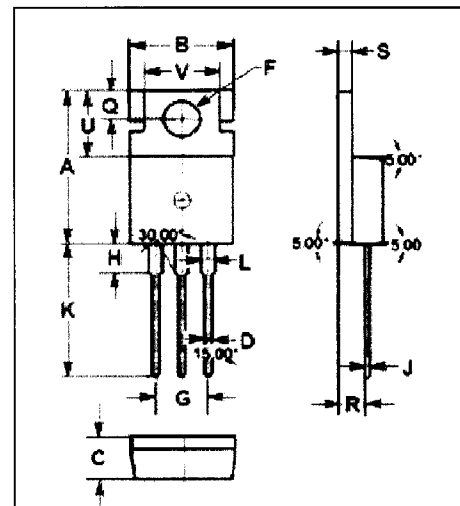

DIM	mm	
	MIN	MAX
A	15.70	15.90
B	9.90	10.10
C	4.20	4.40
D	0.70	0.90
F	3.40	3.60
G	4.98	5.18
H	2.70	2.90
J	0.44	0.46
K	13.20	13.40
L	1.10	1.30
Q	2.70	2.90
R	2.50	2.70
S	1.29	1.31
U	6.45	6.65
V	8.66	8.86

THERMAL CHARACTERISTICS

SYMBOL	PARAMETER	MAX	UNIT
R_{th-jc}	Thermal Resistance, Junction to Case	4.2	$^\circ\text{C/W}$

NJ Semi-Conductors reserves the right to change test conditions, parameter limits and package dimensions without notice. Information furnished by NJ Semi-Conductors is believed to be both accurate and reliable at the time of going to press. However, NJ Semi-Conductors assumes no responsibility for any errors or omissions discovered in its use. NJ Semi-Conductors encourages customers to verify that datasheets are current before placing orders.

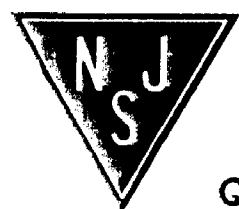

Silicon PNP Power Transistors

D45C4

ELECTRICAL CHARACTERISTICS

$T_C=25^\circ\text{C}$ unless otherwise specified

SYMBOL	PARAMETER	CONDITIONS	MIN	TYP	MAX	UNIT
$V_{CE(sat)}$	Collector-Emitter Saturation Voltage	$I_C = -1\text{A}; I_B = -100\text{mA}$			-0.5	V
$V_{BE(sat)}$	Base-Emitter Saturation Voltage	$I_C = -1\text{A}; I_B = -100\text{mA}$			-1.3	V
I_{CES}	Collector Cutoff Current	$V_{CE} = -55\text{V}; V_{BE} = 0$			-10	μA
I_{EBO}	Emitter Cutoff Current	$V_{EB} = -5\text{V}; I_C = 0$			-100	μA
h_{FE-1}	DC Current Gain	$I_C = -0.2\text{A}; V_{CE} = -1\text{V}$	25			
h_{FE-2}	DC Current Gain	$I_C = -1\text{A}; V_{CE} = -1\text{V}$	10			
f_T	Current-Gain—Bandwidth Product	$I_C = -20\text{mA}; V_{CE} = -4\text{V}; f_{test} = 1\text{MHz}$		40		MHz

Switching Times

t_r	Rise Time	$I_C = -1\text{A}; I_{B1} = -I_{B2} = -0.1\text{A}; V_{CC} = -20\text{V}$			0.2	μs
t_s	Storage Time				0.6	μs
t_f	Fall Time				0.3	μs