

# NPN SILICON RF POWER TRANSISTOR

**DESCRIPTION:**

The **ASI HF100-28** is a class A silicon NPN planar transistor, designed for SSB communications. Diffused ballasting provide High VSRW Capability under rated operating conditions.

**FEATURES:**

- $P_G = 15$  dB min. at 100 W/30 MHz
- High linear power output
- $IMD_3 = -30$  dBc max. at 100 W<sub>(PEP)</sub>
- **Omnigold™** Metalization System
- 28 V CE operation

**MAXIMUM RATINGS**

$I_C$	20 A
$V_{CBO}$	65 V
$V_{CEO}$	36 V
$V_{EBO}$	4.0 V
$P_{DISS}$	270 W @ $T_C = 25^\circ C$
$T_J$	-65 °C to +200 °C
$T_{STG}$	-65 °C to +150 °C
$\theta_{JC}$	0.65 °C/W

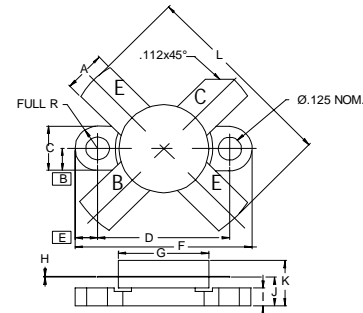
**PACKAGE STYLE .500 4L FLG**

DIM	MINIMUM inches / mm	MAXIMUM inches / mm
A	.220 / 5.59	.230 / 5.84
B	.125 / 3.18	
C	.245 / 6.22	.255 / 6.48
D	.720 / 18.28	.730 / 18.54
E	.125 / 3.18	
F	.970 / 24.64	.980 / 24.89
G	.495 / 12.57	.505 / 12.83
H	.003 / 0.08	.007 / 0.18
I	.090 / 2.29	.110 / 2.79
J	.150 / 3.81	.175 / 4.45
K	.280 / 7.11	
L	.980 / 24.89	1.050 / 26.67

**ORDER CODE: ASI10608**
**CHARACTERISTICS**  $T_C = 25^\circ C$ 

SYMBOL	TEST CONDITIONS		MINIMUM	TYPICAL	MAXIMUM	UNITS
$BV_{CEO}$	$I_C = 100$ mA		35			V
$BV_{CES}$	$I_C = 100$ mA		65			V
$BV_{CBO}$	$I_C = 100$ mA		65			
$BV_{EBO}$	$I_E = 10$ mA		4.0			V
$I_{CES}$	$V_{CE} = 30$ V				15	mA
$h_{FE}$	$V_{CE} = 5.0$ V	$I_C = 5.0$ A	10		200	---
$C_{ob}$	$V_{CB} = 30$ V	$f = 1.0$ MHz	---		285	pF
$G_P$	$V_{CE} = 28$ V	$P_{IN} = 3.16$ W	15	16		dB
$IMD_3$	$f_1 = 30.000$ MHz	$I_{CQ} = 100$ mA		-34	-30	dBc
		$f_2 = 30.001$ MHz				