

SCHEMATIC DIAGRAM FOR PAL-SECAM SYSTEM

MAIN BOARD

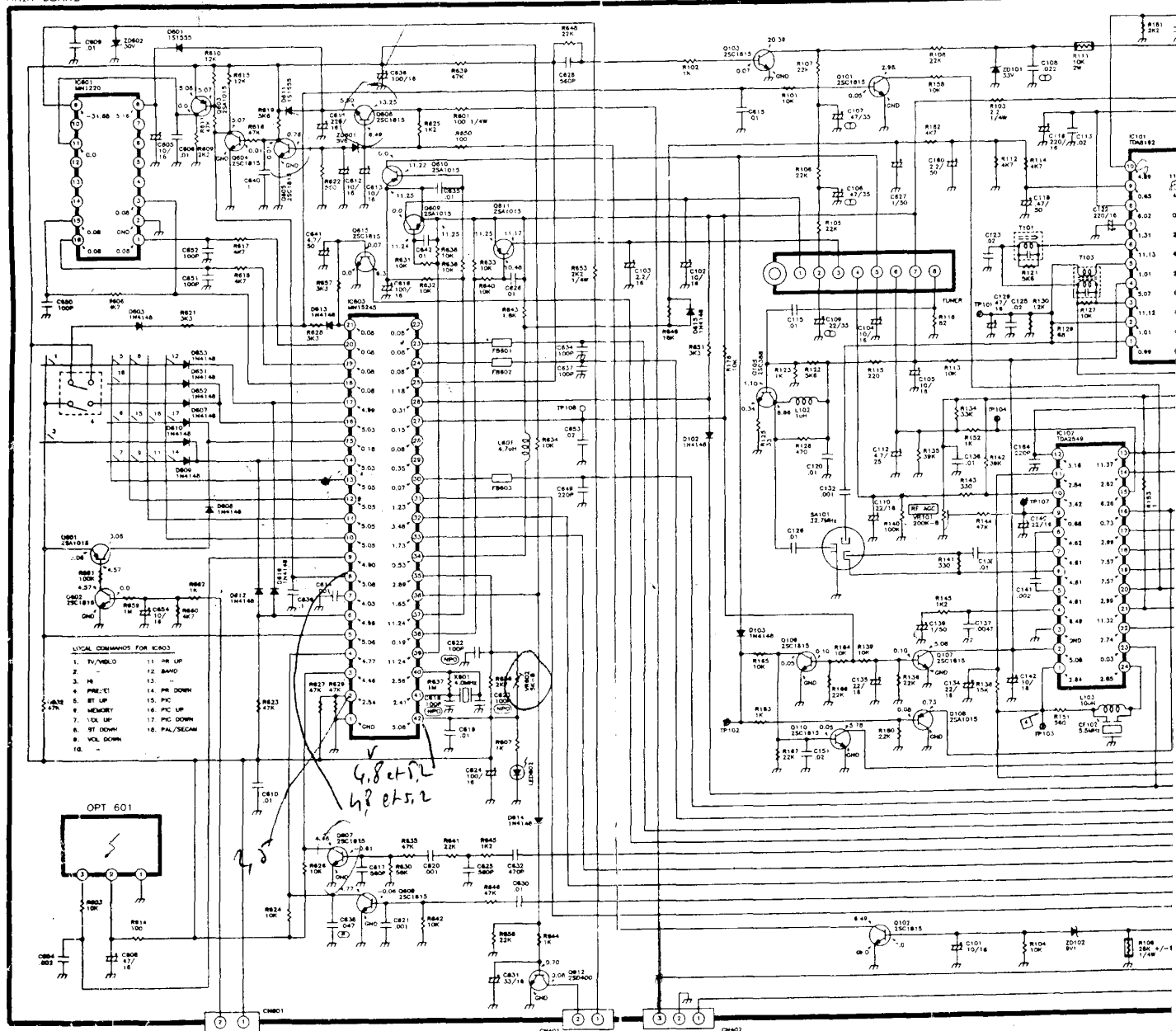

SWITCH BOARD

POWER BOARD

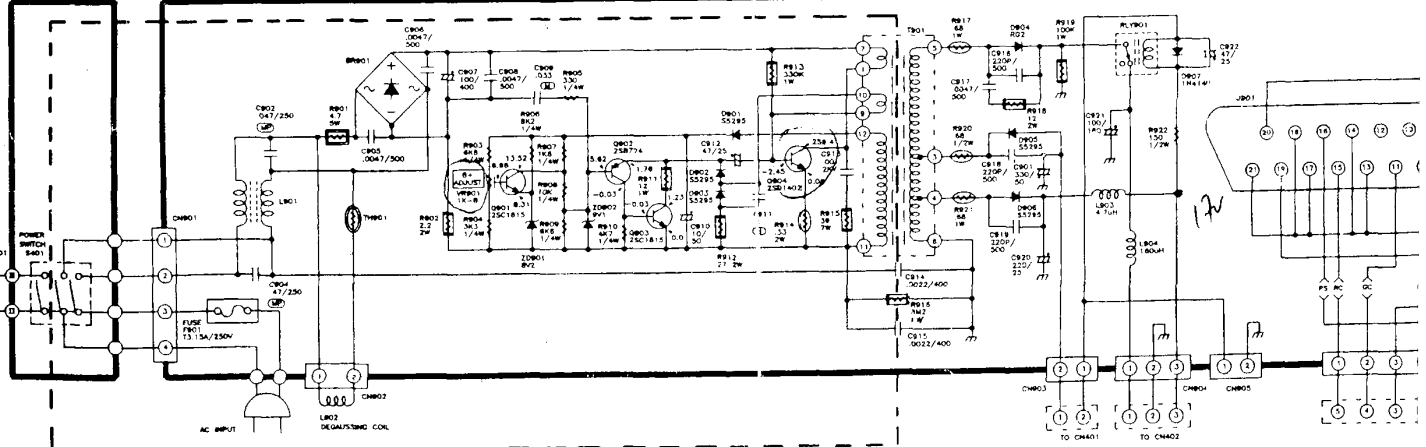

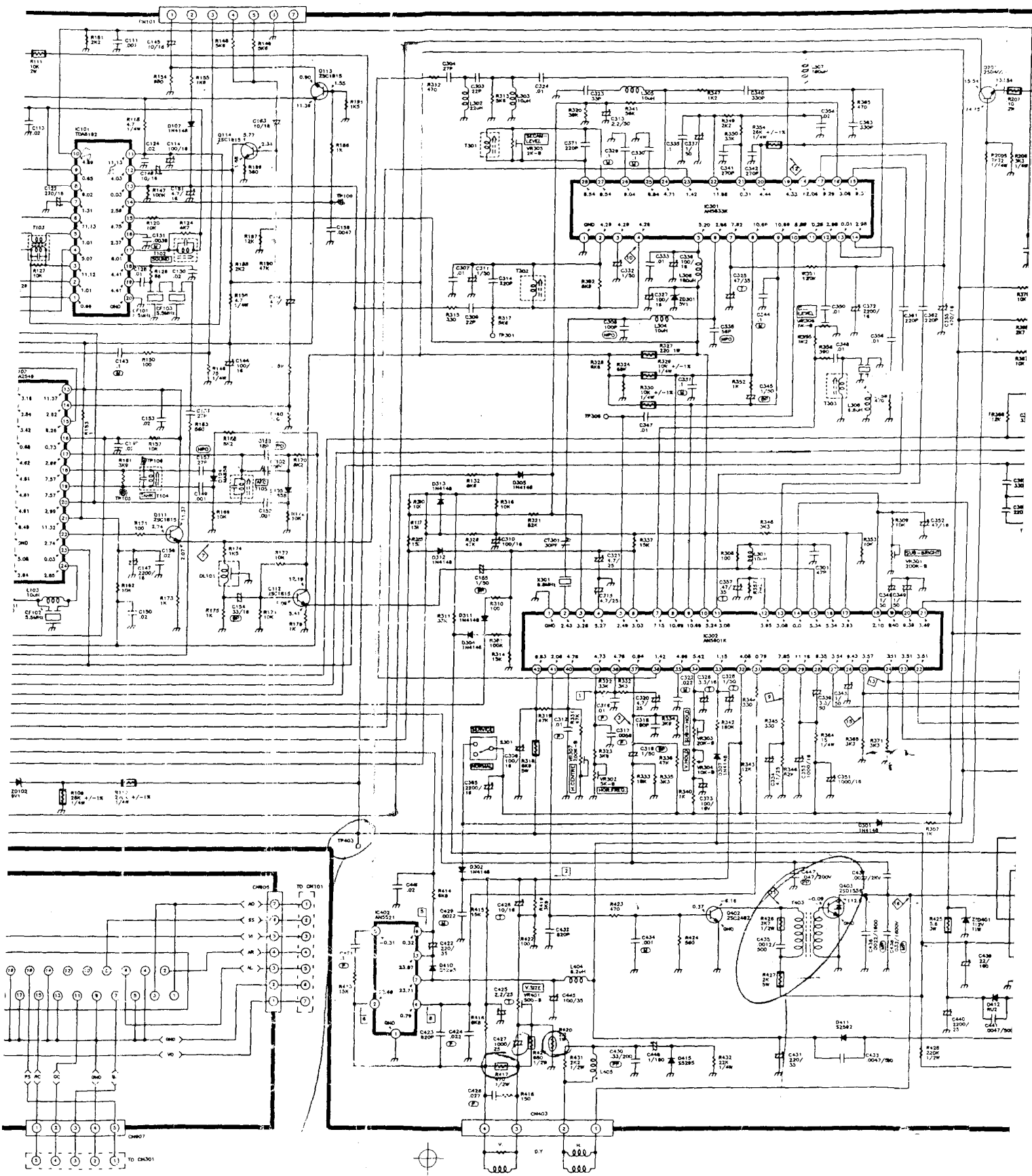

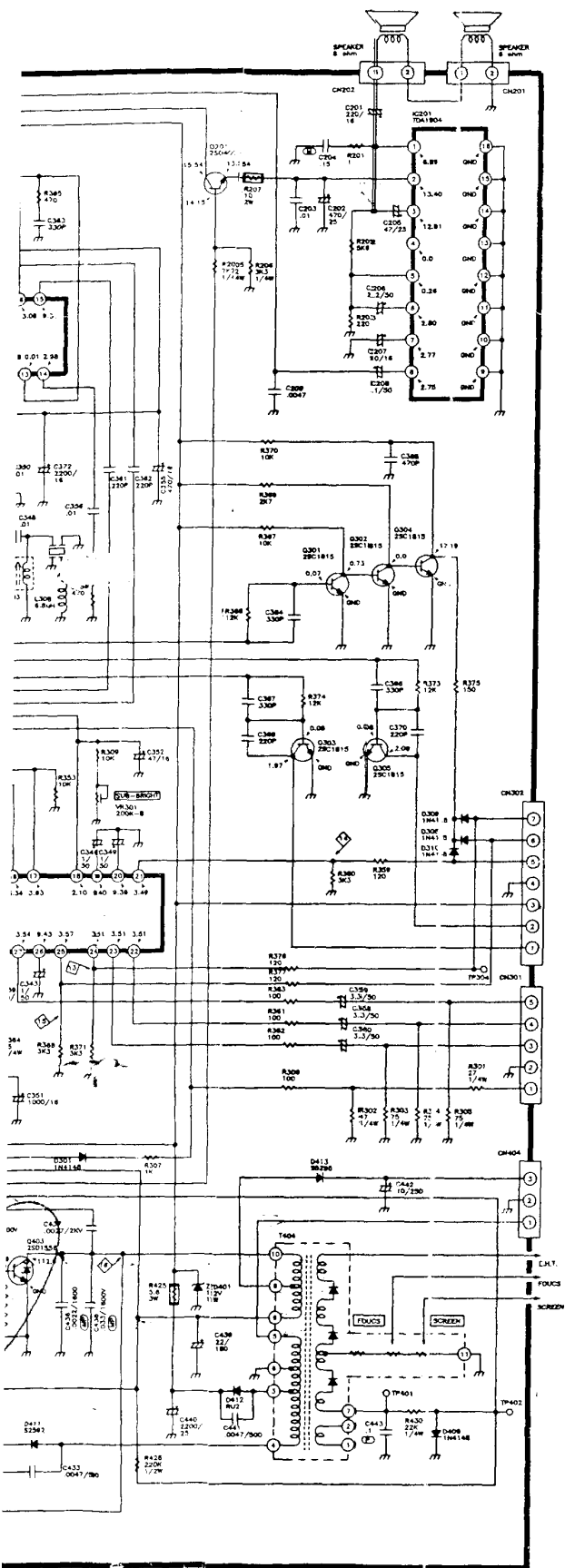

HANDSET BOARD

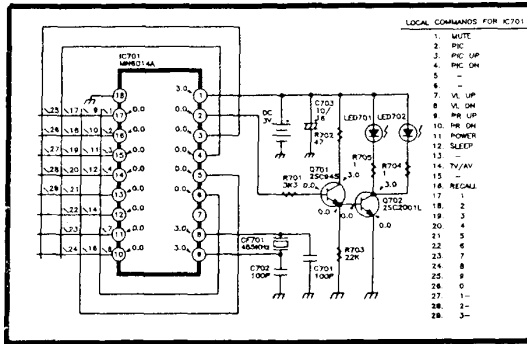

CRT BOARD

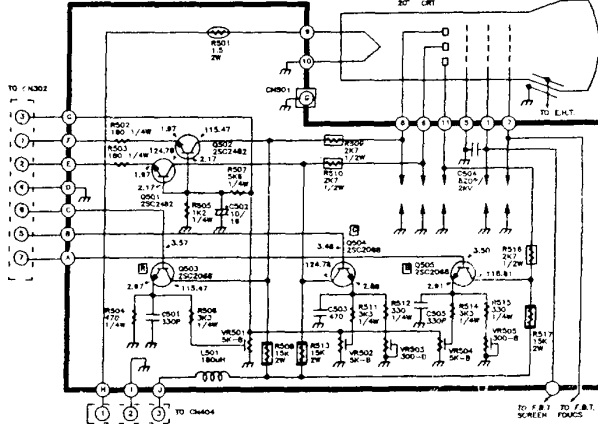

WAVEFORM

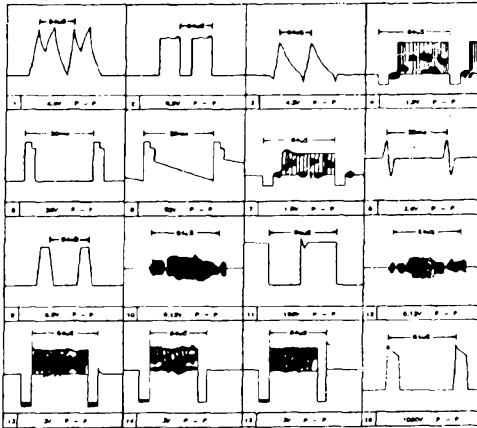

- NOTE:
- (1) ALL CAPACITORS ARE IN μF UNLESS OTHERWISE NOTED
 - (2) CAPACITOR NOT SPECIFICALLY DESIGNATED ARE CERAMIC CAPACITORS.
 - (3) ALL RESISTORS ARE IN OHM 1/16 WATT UNLESS OTHERWISE NOTED.
 - (4) RESISTOR NOT SPECIFICALLY DESIGNATED ARE CARBON FILM RESISTORS
 - (5) DC VOLTAGE ARE MEASURED FROM POINTS INDICATED TO THE CIRCUIT GROUND WITH A DIGITAL MULTIMETER TEST.
 - (6) WAVEFORMS ARE TAKEN WITH SETTING CONTROLS TO A NORMAL CONDITIONS (COLOR PHILIPS PATTERN)
 - (7) THIS CIRCUIT DIAGRAM IS SUBJECT TO CHANGE WITHOUT PRIOR NOTICE.
 - (8) ⚠ SAFETY CRITICAL DEVICE.

CIRCUIT SYMBOLS	
RESISTOR	CAPACITOR
NON-FLAMMABLE	ELECTROLYTIC
FUSIBLE	B. POLAR ELECTROLYTIC
COMPOS	POLYPROPYLENE
METAL OXIDE	MYLAR
THERMISTOR	METALLIZED POLYESTER FILM

KONG WAH VIDEO ENGINEERING LTD.	
TITLE: SCHEMATIC DIAGRAM	
MODEL: R-3922	SYSTEM: PAL-SECAM-1
DRAW NO: 3922-08	COUNTRY: FRANCE
DATE: MAY 10, 1990	REV NO: R (P-2-91)