

Aluminum Capacitors Power Economy Long Life Snap-In

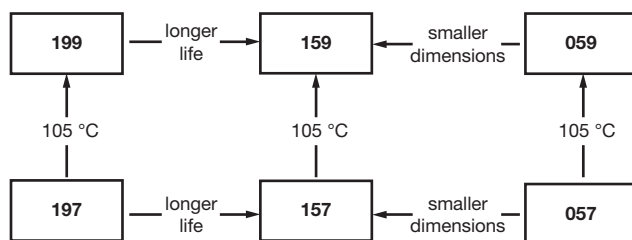

Fig. 1

QUICK REFERENCE DATA	
DESCRIPTION	VALUE
Nominal case size (Ø D x L in mm)	22 x 25 to 35 x 50
Rated capacitance range, C _R	47 µF to 2200 µF
Tolerance on C _R	± 20 %
Rated voltage range, U _R	160 V, 200 V, 250 V, 400 V, 450 V
Category temperature range	- 25 °C to + 105 °C
Endurance test at 105 °C	2000 h
Useful life at 105 °C	3000 h
Useful life at 40 °C and 1.6 x I _R applied	300 000 h
Shelf life at 0 V, 105 °C	500 h
Based on sectional specification	IEC 60384-4/EN130300/W of JISC5141

FEATURES

- Polarized aluminum capacitors, non-solid electrolyte
- Large types, very small dimensions, cylindrical aluminum case, insulated with a blue sleeve
- Useful life: 3000 h at 105 °C
- Compliant to RoHS Directive 2002/95/EC



RoHS
COMPLIANT

APPLICATIONS

- Consumer and industrial electronics
- Whitegood motor control
- Electronic drives
- SMPS/UPS

MARKING

The capacitors are marked (where possible) with the following information:

- Rated capacitance (in µF)
- Tolerance code on rated capacitance, code letter in accordance with IEC 60062 (M for ± 20 %)
- Rated voltage (in V)
- Name of manufacturer
- Date code
- “-” sign to identify the negative terminal, visible from the top and side of the capacitor
- Code number (last 8 digits)
- Maximum operating temperature

SELECTION CHART FOR C _R , U _R , AND RELEVANT NOMINAL CASE SIZES (Ø D x L in mm)					
C _R (µF)	U _R (V)				
	160	200	250	400	450
47	-	-	-	22 x 25	-
56	-	-	-	22 x 25	22 x 25
68	-	-	-	22 x 25	22 x 30
	-	-	-	-	22 x 25
82	-	-	-	22 x 30	22 x 35
	-	-	-	25 x 25	-
100	-	-	-	22 x 35	22 x 40
	-	-	-	25 x 30	25 x 30
	-	-	-	-	30 x 25
120	-	-	-	22 x 35	25 x 35
	-	-	-	25 x 30	-
	-	-	-	30 x 25	-
150	-	-	-	22 x 40	-
	-	-	-	25 x 35	25 x 40
	-	-	-	30 x 30	30 x 30
	-	-	-	-	35 x 25

SELECTION CHART FOR C _R , U _R , AND RELEVANT NOMINAL CASE SIZES (Ø D x L in mm)					
C _R (µF)	U _R (V)				
	160	200	250	400	450
180	-	-	-	25 x 40	-
	-	-	-	30 x 30	30 x 35
	-	-	-	35 x 25	-
220	-	-	22 x 30	-	-
	-	-	25 x 25	-	30 x 40
	-	-	-	30 x 35	35 x 30
	-	-	-	35 x 30	-
270	-	-	22 x 35	25 x 50	30 x 45
	-	-	25 x 30	30 x 40	35 x 35
	-	-	30 x 25	35 x 30	-
330	22 x 25	22 x 35	22 x 40	-	30 x 50
	-	-	25 x 30	30 x 45	35 x 40
	-	-	30 x 25	35 x 35	-
390	22 x 30	22 x 35	-	30 x 50	-
	-	25 x 30	25 x 35	35 x 40	35 x 45
	-	-	30 x 30	-	-
470	22 x 35	-	-	-	35 x 50
	-	-	25 x 40	35 x 50	-
	-	30 x 25	30 x 30	-	-
	-	-	35 x 25	35 x 45	-
560	22 x 40	-	-	-	-
	25 x 30	-	-	-	-
	-	30 x 30	30 x 35	35 x 50	-
	-	-	35 x 30	-	-
680	25 x 35	-	-	-	-
	-	30 x 30	30 x 40	-	-
	-	-	35 x 35	-	-
	-	35 x 25	-	-	-
820	25 x 40	25 x 50	30 x 45	-	-
	30 x 30	30 x 35	35 x 35	-	-
	35 x 25	35 x 30	35 x 40	-	-
1000	30 x 35	30 x 45	-	-	-
	35 x 30	35 x 35	35 x 40	-	-
	-	-	35 x 45	-	-
1200	25 x 50	30 x 50	35 x 45	-	-
	30 x 40	-	35 x 50	-	-
	35 x 30	-	-	-	-
1500	30 x 45	35 x 45	-	-	-
	35 x 35	-	-	-	-
1800	30 x 50	-	-	-	-
	35 x 45	35 x 50	-	-	-
2200	35 x 50	-	-	-	-

DIMENSIONS in millimeters AND AVAILABLE FORMS

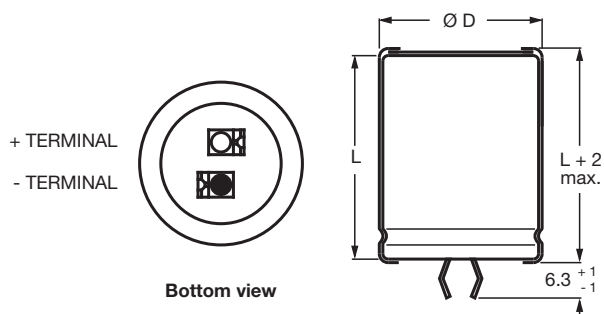

The minus terminal can be marked with a black dot or an imprinted sign.
Fig. 2 - Two terminal snap-in

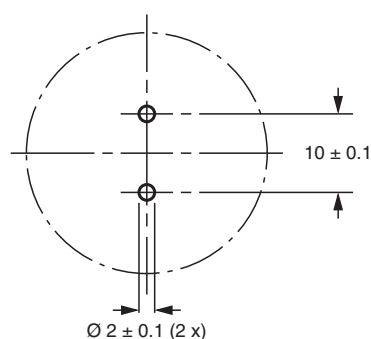

Fig. 3 - Mounting hole diagram



Aluminum Capacitors
Power Economy Long Life Snap-In

Vishay BCcomponents

Table 1

DIMENSIONS in millimeters, MASS AND PACKAGING QUANTITIES					
NOMINAL CASE SIZE Ø D x L	Ø D _{MAX.}	L _{MAX.}	MASS (g)	PACKAGING QUANTITIES	CARDBOARD BOX DIMENSIONS L x W x H
22 x 25	22.5	26.5	≈ 12	216	280 x 240 x 140
22 x 30	22.5	31.5	≈ 16	216	280 x 240 x 140
22 x 35	22.5	36.5	≈ 20	144	280 x 240 x 105
22 x 40	22.5	41.5	≈ 23	144	280 x 240 x 105
22 x 45	22.5	46.5	≈ 26	144	280 x 240 x 140
22 x 50	22.5	51.5	≈ 29	72	280 x 240 x 105
25 x 25	25.5	26.5	≈ 20	216	280 x 240 x 140
25 x 30	25.5	33.5	≈ 22	216	280 x 240 x 140
25 x 35	25.5	36.5	≈ 24	144	280 x 240 x 105
25 x 40	25.5	41.5	≈ 27	144	280 x 240 x 105
25 x 45	25.5	46.5	≈ 32	144	280 x 240 x 140
25 x 50	25.5	51.5	≈ 38	144	280 x 240 x 140
30 x 25	30.5	28.5	≈ 25	168	280 x 240 x 140
30 x 30	30.5	33.5	≈ 30	168	280 x 240 x 140
30 x 35	30.5	38.5	≈ 35	112	280 x 240 x 105
30 x 40	30.5	42.5	≈ 40	112	280 x 240 x 105
30 x 45	30.5	47.5	≈ 45	112	280 x 240 x 140
30 x 50	30.5	52.5	≈ 50	112	280 x 240 x 140
35 x 25	35.5	26.5	≈ 33	126	280 x 240 x 140
35 x 30	35.5	33.5	≈ 40	126	280 x 240 x 140
35 x 35	35.5	36.5	≈ 48	84	280 x 240 x 105
35 x 40	35.5	42.5	≈ 55	84	280 x 240 x 105
35 x 45	35.5	47.5	≈ 63	84	280 x 240 x 140
35 x 50	35.5	52.5	≈ 72	84	280 x 240 x 140

ELECTRICAL DATA	
SYMBOL	DESCRIPTION
C _R	Rated capacitance at 120 Hz
I _R	Rated RMS ripple current at 120 Hz, 105 °C
I _{L5}	Max. leakage current after 5 min at U _R
ESR	Max. equivalent series resistance at 120 Hz ⁽¹⁾

Notes

⁽¹⁾ ESR at 100 Hz is approximately 1.05 x ESR 120 Hz

- Unless otherwise specified, all electrical values in table 2 apply at T_{amb} = 20 °C, P = 86 kPa to 106 kPa, RH = 45 % to 75 %

ORDERING EXAMPLE

Electrolytic capacitor 199 series

820 µF/160 V; ± 20 %

Nominal case size: Ø 25 mm x 40 mm

Ordering code: MAL2 199 51821 E3

Former 12NC: 2222 199 51821

Table 2

ELECTRICAL DATA AND ORDERING INFORMATION							
U _R (V)	C _R 120 Hz (µF)	NOMINAL CASE SIZE Ø D x L (mm)	I _R 120 Hz (A)	I _{L5} (mA)	MAX. ESR 120 Hz ⁽¹⁾ (Ω)	MAX. Z 10 kHz (mΩ)	ORDERING CODE MAL2199.....
160	330	22 x 25	1.00	1.06	0.50	316	51331E3
	390	22 x 30	1.17	1.25	0.43	260	51391E3
	470	22 x 35	1.35	1.50	0.35	216	51471E3
	560	22 x 40	1.53	1.50	0.30	183	51561E3
	560	25 x 30	1.42	1.50	0.30	199	41561E3
	680	25 x 35	1.60	1.50	0.24	170	51681E3
	820	25 x 40	1.80	1.50	0.20	144	51821E3
	820	30 x 30	1.67	1.50	0.20	166	41821E3
	820	35 x 25	1.44	1.50	0.30	219	31821E3
	1000	30 x 35	1.86	1.50	0.17	144	41102E3



ELECTRICAL DATA AND ORDERING INFORMATION							
U _R (V)	C _R 120 Hz (μF)	NOMINAL CASE SIZE Ø D x L (mm)	I _R 120 Hz (A)	I _{L5} (mA)	MAX. ESR 120 Hz ⁽¹⁾ (Ω)	MAX. Z 10 kHz (mΩ)	ORDERING CODE MAL2199.....
160	1000	35 x 30	1.82	1.50	0.25	157	31102E3
	1200	25 x 50	2.24	1.50	0.14	105	51122E3
	1200	30 x 40	2.06	1.50	0.21	124	41122E3
	1200	35 x 30	1.81	1.50	0.21	152	31122E3
	1500	30 x 45	2.30	1.50	0.11	106	51152E3
	1500	35 x 35	1.97	1.50	0.17	134	41152E3
	1800	30 x 50	2.51	1.50	0.09	92	51182E3
	1800	35 x 45	2.45	1.50	0.14	102	41182E3
	2200	35 x 50	2.66	1.50	0.11	90	51222E3
200	330	22 x 35	1.19	1.32	0.50	241	42331E3
	390	22 x 35	1.27	1.50	0.43	212	42391E3
	390	25 x 30	1.27	1.50	0.43	219	52391E3
	470	30 x 25	1.28	1.50	0.35	231	52471E3
	560	30 x 30	1.53	1.50	0.30	180	52561E3
	680	30 x 30	1.57	1.50	0.24	167	52681E3
	680	35 x 25	1.36	1.50	0.37	225	62681E3
	820	25 x 50	2.04	1.50	0.20	115	32821E3
	820	30 x 35	1.75	1.50	0.20	146	42821E3
	820	35 x 30	1.72	1.50	0.30	160	52821E3
	1000	30 x 45	2.14	1.50	0.17	113	42102E3
	1000	35 x 35	1.90	1.50	0.25	140	52102E3
	1200	30 x 50	2.36	1.50	0.14	98	42122E3
	1500	35 x 45	2.31	1.50	0.17	104	52152E3
	1800	35 x 50	2.52	1.50	0.14	92	52182E3
250	220	22 x 30	1.14	1.10	0.75	294	43221E3
	220	25 x 25	0.94	1.10	0.75	317	53221E3
	270	22 x 35	1.11	1.35	0.61	240	43271E3
	270	25 x 30	1.12	1.35	0.61	247	53271E3
	270	30 x 25	1.11	1.35	0.61	274	63271E3
	330	22 x 40	1.27	1.50	0.50	199	33331E3
	330	25 x 30	1.20	1.50	0.50	216	43331E3
	330	30 x 25	1.17	1.50	0.50	250	53331E3
	390	25 x 35	1.35	1.50	0.43	186	43391E3
	390	30 x 30	1.38	1.50	0.43	196	53391E3
	470	25 x 40	1.52	1.50	0.35	158	33471E3
	470	30 x 30	1.43	1.50	0.35	181	43471E3
	470	35 x 25	1.28	1.50	0.53	240	53471E3
	560	30 x 35	1.60	1.50	0.30	158	53561E3
	560	35 x 30	1.59	1.50	0.44	172	63561E3
	680	30 x 40	1.79	1.50	0.24	135	43681E3
	680	35 x 35	1.76	1.50	0.37	150	53682E3
	820	30 x 45	2.00	1.50	0.20	116	43821E3
	820	35 x 35	1.77	1.50	0.30	147	53821E3
	820	35 x 40	1.96	1.50	0.30	130	63821E3
	1000	35 x 40	1.96	1.50	0.25	127	53102E3
	1000	35 x 45	2.17	1.50	0.25	111	63102E3
	1200	35 x 45	2.16	1.50	0.21	110	43122E3
	1200	35 x 50	2.38	1.50	0.21	98	53122E3



Aluminum Capacitors
Power Economy Long Life Snap-In

Vishay BCcomponents

ELECTRICAL DATA AND ORDERING INFORMATION							
U_R (V)	C_R 120 Hz (μ F)	NOMINAL CASE SIZE \varnothing D x L (mm)	I_R 120 Hz (A)	I_{L5} (mA)	MAX. ESR 120 Hz ⁽¹⁾ (Ω)	MAX. Z 10 kHz (m Ω)	ORDERING CODE MAL2199.....
400	47	22 x 25	0.41	0.38	5.29	3127	56479E3
	56	22 x 25	0.45	0.45	4.44	2635	56569E3
	68	22 x 25	0.49	0.54	3.66	2161	56689E3
	82	22 x 30	0.57	0.66	3.03	1788	46829E3
	82	25 x 25	0.58	0.66	3.03	1808	56829E3
	100	22 x 35	0.66	0.80	2.49	1467	46101E3
	100	25 x 30	0.67	0.80	2.49	1472	56101E3
	120	22 x 35	0.72	0.96	2.07	1231	46121E3
	120	25 x 30	0.73	0.96	2.07	1238	56121E3
	120	30 x 25	0.75	0.96	2.07	1266	66121E3
	150	22 x 40	0.84	1.20	1.66	990	36151E3
	150	25 x 35	0.85	1.20	1.66	997	46151E3
	150	30 x 30	0.89	1.20	1.66	1006	56151E3
	180	25 x 40	0.97	1.44	1.38	835	36181E3
	180	30 x 30	0.96	1.44	1.38	854	46181E3
	180	35 x 25	0.94	1.44	1.38	907	56181E3
	220	30 x 35	1.09	1.50	1.13	707	56221E3
	220	35 x 30	1.12	1.50	1.13	719	66221E3
	270	25 x 50	1.25	1.50	0.92	564	46271E3
	270	30 x 40	1.24	1.50	0.92	582	56271E3
	270	35 x 30	1.19	1.50	0.92	611	66271E3
	330	30 x 45	1.41	1.50	0.75	480	56331E3
	330	35 x 35	1.34	1.50	0.75	510	66331E3
390	30 x 50	1.56	1.50	0.64	410	46391E3	
390	35 x 40	1.50	1.50	0.64	435	56391E3	
470	35 x 45	1.68	1.50	0.53	365	56471E3	
470	35 x 50	1.68	1.50	0.53	365	66471E3	
560	35 x 50	1.85	1.50	0.44	311	56561E3	
450	56	22 x 25	0.46	0.50	4.44	2161	57569E3
	68	22 x 30	0.53	0.61	3.66	1776	47689E3
	68	25 x 25	0.54	0.61	3.66	1797	57689E3
	82	22 x 35	0.62	0.74	3.03	1473	57829E3
	100	22 x 40	0.71	0.90	2.49	1211	37101E3
	100	25 x 30	0.69	0.90	2.49	1225	47101E3
	100	30 x 25	0.71	0.90	2.49	1254	57101E3
	120	25 x 35	0.78	1.08	2.07	1025	57121E3
	150	25 x 40	0.91	1.35	1.66	826	47151E3
	150	30 x 30	0.90	1.35	1.66	847	57151E3
	150	35 x 25	0.89	1.35	1.66	902	67151E3
	180	30 x 35	1.02	1.50	1.38	712	57181E3
	220	30 x 40	1.16	1.50	1.13	588	47221E3
	220	35 x 30	1.12	1.50	1.13	618	57221E3
	270	30 x 45	1.31	1.50	0.92	484	47271E3
	270	35 x 35	1.26	1.50	0.75	515	57271E3
	330	30 x 50	1.48	1.50	0.75	402	47331E3
	330	35 x 40	1.42	1.50	1.13	429	57331E3
	390	35 x 45	1.58	1.50	0.64	365	57391E3
	470	35 x 50	1.76	1.50	0.53	309	57471E3

Note⁽²⁾ ESR at 100 Hz is approximately 1.05 x ESR 120 Hz



ADDITIONAL ELECTRICAL DATA		
PARAMETER	CONDITIONS	VALUE
Voltage		
Surge voltage	≥ 400 V versions	$U_S = 1.1 \times U_R$
	≤ 250 V versions	$U_S = 1.15 \times U_R$
Reverse voltage	≤ 1 V	-
Current		
Leakage current	After 5 min at U_R	$I_{L5} \leq 0.02 C_R \times U_R$ or 1.5 mA, whichever is smaller
Inductance		
Equivalent series inductance (ESL)	All case sizes	19 nH typical/25 nH max.

Table 3

LOW TEMPERATURE CHARACTERISTIC (at 120 Hz)						
DESCRIPTION		U_R (V) ⁽¹⁾				
		160	200	250	400	450
Impedance ratio	$Z(-25\text{ °C})/Z(+20\text{ °C})$	4	4	4	4	4

Note

⁽¹⁾ Impedance ratio shall not exceed the given values

RIPPLE CURRENT AND USEFUL LIFE

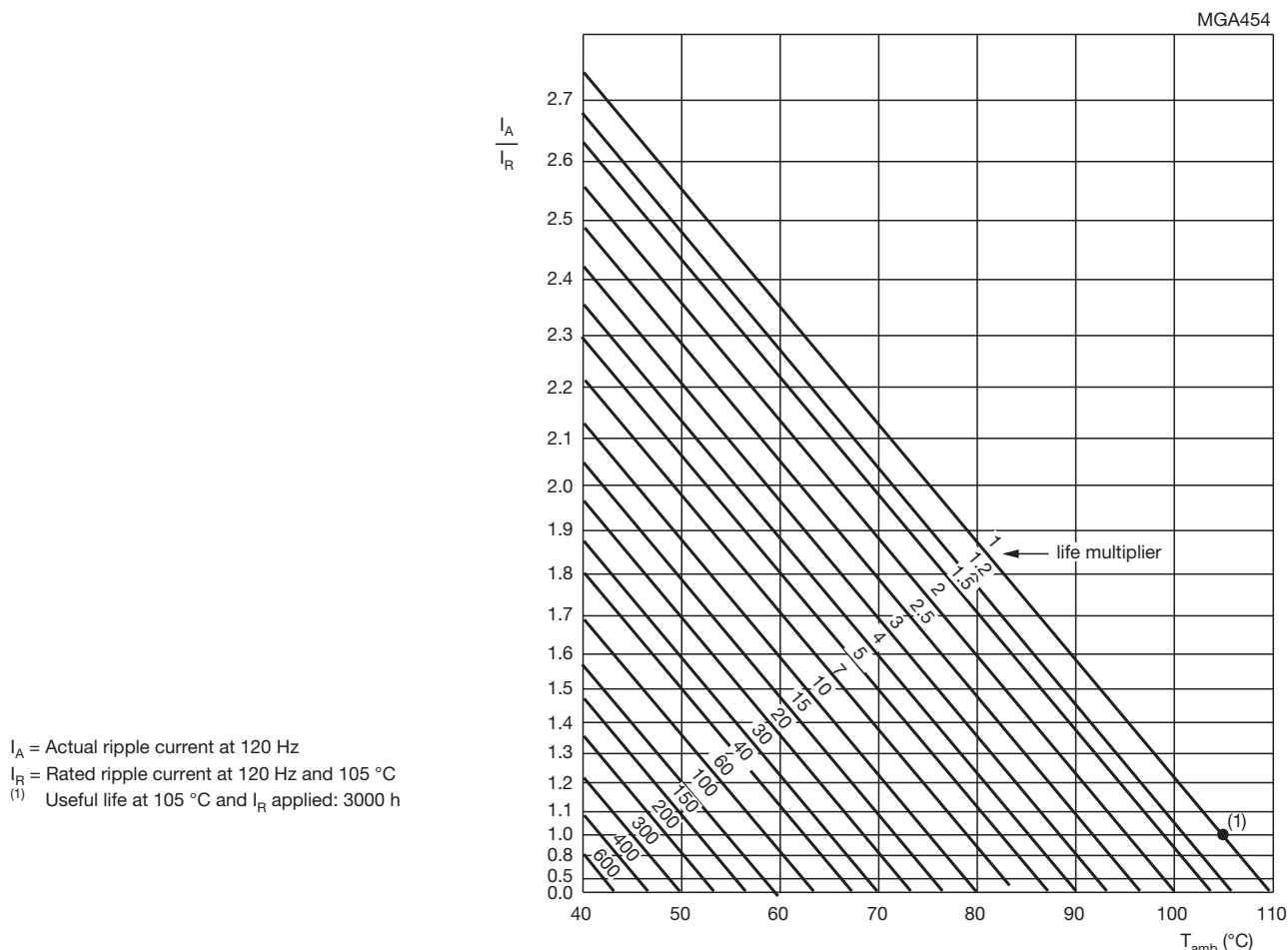

Fig. 4 - Multiplier of useful life as a function of ambient temperature and ripple current load



Table 4

MULTIPLIER OF RIPPLE CURRENT (I_R) AS A FUNCTION OF FREQUENCY	
FREQUENCY (Hz)	I_R MULTIPLIER
50	0.90
100	0.95
120	1.00
500	1.20
1000	1.30
$\geq 10\,000$	1.40

Table 5

TEST PROCEDURES AND REQUIREMENTS			
TEST		PROCEDURE (quick reference)	REQUIREMENTS
NAME OF TEST	REFERENCE		
Endurance	IEC 60384-4/EN130300 subclause 4.13	$T_{amb} = 105\text{ °C}$; U_R applied: 2000 h	$\Delta C/C: \pm 15\%$ ESR $\leq 1.3 \times$ spec. limit $I_{L5} \leq$ spec. limit
Useful life	CECC 30301 subclause 1.8.1	$T_{amb} = 105\text{ °C}$; U_R and I_R applied: 3000 h	$\Delta C/C: \pm 30\%$ ESR $\leq 3 \times$ spec. limit $I_{L5} \leq$ spec. limit no short or open circuit, no visible damage total failure percentage: $\leq 3\%$
Shelf life (storage at high temperature)	IEC 60384-4/EN130300 subclause 4.17	$T_{amb} = 105\text{ °C}$; no voltage applied; 500 h after test: U_R to be applied for 30 min, 24 h to 48 h before measurement	$\Delta C/C: \pm 20\%$ ESR $\leq 2 \times$ spec. limit $I_{L5} \leq 1 \times$ spec. limit



Disclaimer

ALL PRODUCT, PRODUCT SPECIFICATIONS AND DATA ARE SUBJECT TO CHANGE WITHOUT NOTICE TO IMPROVE RELIABILITY, FUNCTION OR DESIGN OR OTHERWISE.

Vishay Intertechnology, Inc., its affiliates, agents, and employees, and all persons acting on its or their behalf (collectively, "Vishay"), disclaim any and all liability for any errors, inaccuracies or incompleteness contained in any datasheet or in any other disclosure relating to any product.

Vishay makes no warranty, representation or guarantee regarding the suitability of the products for any particular purpose or the continuing production of any product. To the maximum extent permitted by applicable law, Vishay disclaims (i) any and all liability arising out of the application or use of any product, (ii) any and all liability, including without limitation special, consequential or incidental damages, and (iii) any and all implied warranties, including warranties of fitness for particular purpose, non-infringement and merchantability.

Statements regarding the suitability of products for certain types of applications are based on Vishay's knowledge of typical requirements that are often placed on Vishay products in generic applications. Such statements are not binding statements about the suitability of products for a particular application. It is the customer's responsibility to validate that a particular product with the properties described in the product specification is suitable for use in a particular application. Parameters provided in datasheets and/or specifications may vary in different applications and performance may vary over time. All operating parameters, including typical parameters, must be validated for each customer application by the customer's technical experts. Product specifications do not expand or otherwise modify Vishay's terms and conditions of purchase, including but not limited to the warranty expressed therein.

Except as expressly indicated in writing, Vishay products are not designed for use in medical, life-saving, or life-sustaining applications or for any other application in which the failure of the Vishay product could result in personal injury or death. Customers using or selling Vishay products not expressly indicated for use in such applications do so at their own risk. Please contact authorized Vishay personnel to obtain written terms and conditions regarding products designed for such applications.

No license, express or implied, by estoppel or otherwise, to any intellectual property rights is granted by this document or by any conduct of Vishay. Product names and markings noted herein may be trademarks of their respective owners.

Material Category Policy

Vishay Intertechnology, Inc. hereby certifies that all its products that are identified as RoHS-Compliant fulfill the definitions and restrictions defined under Directive 2011/65/EU of The European Parliament and of the Council of June 8, 2011 on the restriction of the use of certain hazardous substances in electrical and electronic equipment (EEE) - recast, unless otherwise specified as non-compliant.

Please note that some Vishay documentation may still make reference to RoHS Directive 2002/95/EC. We confirm that all the products identified as being compliant to Directive 2002/95/EC conform to Directive 2011/65/EU.

Vishay Intertechnology, Inc. hereby certifies that all its products that are identified as Halogen-Free follow Halogen-Free requirements as per JEDEC JS709A standards. Please note that some Vishay documentation may still make reference to the IEC 61249-2-21 definition. We confirm that all the products identified as being compliant to IEC 61249-2-21 conform to JEDEC JS709A standards.