

Aluminum Capacitors Powerlytic[®], Large Can



FEATURES

- High capacitance per case size
- High ripple current
- Low leakage current
- Long shelf life and operating life
- Type 36D ratings recommended for replacement applications only. For new designs, see type 36DY.
- Screw terminal
- Material categorization: For definitions of compliance please see www.vishay.com/doc?99912

**RoHS
COMPLIANT**

QUICK REFERENCE DATA	
DESCRIPTION	VALUE
Nominal case size Ø D x L in inches (mm)	1.453 x 2.250 (36.9 x 57.2) to 3.078 x 8.750 (78.2 x 222.3)
Operating temperature	- 40 °C to + 85 °C (36DX) - 40 °C to + 95 °C (36DE)
Rated capacitance range, C _R	190 µF to 50 000 µF
Tolerance on C _R	+ 75 %, - 10 % (10 WV _{DC} to 100 WV _{DC}) + 50 %, - 10 % (200 WV _{DC} to 450 WV _{DC})
Rated voltage range, U _R	10 WV _{DC} to 450 WV _{DC}
Life validation test at 85 °C	1000 h: ΔCAP ± 15 % from initial measurement. ΔESR 1.5 x initial specified limit

DIMENSIONS in inches (millimeters)							
LARGE CAN CAPACITORS							
CASE CODE	NOMINAL		WITH INSULATION SLEEVE			TERMINAL SPACING M ± 0.016 (0.4)	TYPICAL WEIGHT (g)
	D ± 0.032 (0.8)	L ± 0.063 (1.6)	D (Max.)	L (Max.)	P TERMINAL H (Max.)		
AN	1.375 (35.0)	1.625 (41.0)	1.453 (36.9)	1.750 (44.5)	1.849 (47.0)	0.500 (12.7)	43.0
AY	1.375 (35.0)	1.875 (48.0)	1.453 (36.9)	2.000 (50.8)	1.099 (53.3)	0.500 (12.7)	54.0
AA	1.375 (35.0)	2.125 (54.0)	1.453 (36.9)	2.250 (57.2)	1.349 (59.7)	0.500 (12.7)	63.0
AM	1.375 (35.0)	2.625 (67.0)	1.453 (36.9)	2.750 (69.9)	1.849 (72.4)	0.500 (12.7)	82.0
AB	1.375 (35.0)	3.125 (79.0)	1.453 (36.9)	3.250 (82.6)	1.349 (85.1)	0.500 (12.7)	105.0
AL	1.375 (35.0)	3.625 (92.0)	1.453 (36.9)	3.750 (95.3)	1.849 (97.8)	0.500 (12.7)	122.0
AC	1.375 (35.0)	4.125 (105.0)	1.453 (36.9)	4.250 (108.0)	1.349 (110.5)	0.500 (12.7)	129.0
AD	1.375 (35.0)	4.625 (117.0)	1.453 (36.9)	4.750 (120.7)	1.849 (123.2)	0.500 (12.7)	162.0
AE	1.375 (35.0)	5.125 (130.0)	1.453 (36.9)	5.250 (133.4)	1.349 (125.9)	0.500 (12.7)	179.0
AF	1.375 (35.0)	5.625 (143.0)	1.453 (36.9)	5.750 (146.1)	1.849 (148.6)	0.500 (12.7)	201.0
EN	1.750 (44.0)	1.625 (41.0)	1.828 (46.4)	1.750 (44.5)	1.849 (47.0)	0.750 (19.1)	71.0
EY	1.750 (44.0)	1.875 (48.0)	1.828 (46.4)	2.000 (50.8)	2.099 (53.3)	0.750 (19.1)	88.0
EA	1.750 (44.0)	2.125 (54.0)	1.828 (46.4)	2.250 (57.2)	2.349 (59.7)	0.750 (19.1)	102.0
EM	1.750 (44.0)	2.625 (67.0)	1.828 (46.4)	2.750 (69.9)	2.849 (72.4)	0.750 (19.1)	133.0
EB	1.750 (44.0)	3.125 (79.0)	1.828 (46.4)	3.250 (82.6)	3.349 (85.1)	0.750 (19.1)	167.0
EL	1.750 (44.0)	3.625 (92.0)	1.828 (46.4)	3.750 (95.3)	3.849 (97.8)	0.750 (19.1)	198.0
EC	1.750 (44.0)	4.125 (105.0)	1.828 (46.4)	4.250 (108.0)	4.349 (110.5)	0.750 (19.1)	230.0
ED	1.750 (44.0)	4.625 (117.0)	1.828 (46.4)	4.750 (120.7)	4.849 (123.2)	0.750 (19.1)	252.0
EE	1.750 (44.0)	5.125 (130.0)	1.828 (46.4)	5.250 (133.4)	5.349 (135.9)	0.750 (19.1)	269.0
EF	1.750 (44.0)	5.625 (143.0)	1.828 (46.4)	5.750 (146.1)	5.849 (148.6)	0.750 (19.1)	318.0



DIMENSIONS in inches (millimeters)							
LARGE CAN CAPACITORS							
CASE CODE	NOMINAL		WITH INSULATION SLEEVE			TERMINAL SPACING M ± 0.016 (0.4)	TYPICAL WEIGHT (g)
	D ± 0.032 (0.8)	L ± 0.063 (1.6)	D (Max.)	L (Max.)	P TERMINAL H (Max.)		
BY	2.000 (51.0)	1.875 (48.0)	2.078 (52.8)	2.000 (50.8)	2.099 (53.3)	0.875 (22.2)	113.0
BA	2.000 (51.0)	2.125 (54.0)	2.078 (52.8)	2.250 (57.2)	2.349 (59.7)	0.875 (22.2)	133.0
BM	2.000 (51.0)	2.625 (67.0)	2.078 (52.8)	2.750 (69.9)	2.849 (72.4)	0.875 (22.2)	176.0
BB	2.000 (51.0)	3.125 (79.0)	2.078 (52.8)	3.250 (82.6)	3.349 (85.1)	0.875 (22.2)	213.0
BL	2.000 (51.0)	3.625 (92.0)	2.078 (52.8)	3.750 (95.3)	3.849 (97.8)	0.875 (22.2)	261.0
BC	2.000 (51.0)	4.125 (105.0)	2.078 (52.8)	4.250 (108.0)	4.349 (110.5)	0.875 (22.2)	381.0
BD	2.000 (51.0)	4.625 (117.0)	2.078 (52.8)	4.750 (120.7)	4.849 (123.2)	0.875 (22.2)	326.0
BE	2.000 (51.0)	5.125 (130.0)	2.078 (52.8)	5.250 (133.4)	5.349 (135.9)	0.875 (22.2)	337.0
BF	2.000 (51.0)	5.625 (143.0)	2.078 (52.8)	5.750 (146.1)	5.849 (148.6)	0.875 (22.2)	408.0
CB	2.500 (64.0)	3.125 (79.0)	2.578 (65.5)	3.250 (82.6)	n/a	1.125 (28.6)	329.0
CL	2.500 (64.0)	3.625 (92.0)	2.578 (65.5)	3.750 (95.3)	n/a	1.125 (28.6)	400.0
CC	2.500 (64.0)	4.125 (105.0)	2.578 (65.5)	4.250 (108.0)	n/a	1.125 (28.6)	473.0
CD	2.500 (64.0)	4.625 (117.0)	2.578 (65.5)	4.750 (120.7)	n/a	1.125 (28.6)	562.0
CE	2.500 (64.0)	5.125 (130.0)	2.578 (65.5)	5.250 (133.4)	n/a	1.125 (28.6)	607.0
CF	2.500 (64.0)	5.625 (143.0)	2.578 (65.5)	5.750 (146.1)	n/a	1.125 (28.6)	675.0
DB	3.000 (76.0)	3.125 (79.0)	3.078 (78.2)	3.250 (82.6)	n/a	1.250 (31.8)	496.0
DL	3.000 (76.0)	3.625 (92.0)	3.078 (78.2)	3.750 (95.3)	n/a	1.250 (31.8)	598.0
DC	3.000 (76.0)	4.125 (105.0)	3.078 (78.2)	4.250 (108.0)	n/a	1.250 (31.8)	700.0
DD	3.000 (76.0)	4.625 (117.0)	3.078 (78.2)	4.750 (120.7)	n/a	1.250 (31.8)	802.0
DE	3.000 (76.0)	5.125 (130.0)	3.078 (78.2)	5.250 (133.4)	n/a	1.250 (31.8)	944.0
DF	3.000 (76.0)	5.625 (143.0)	3.078 (78.2)	5.750 (146.1)	n/a	1.250 (31.8)	1004.0
DJ	3.000 (76.0)	8.625 (219.0)	3.078 (78.2)	8.750 (222.3)	n/a	1.250 (31.8)	1403.0

DIMENSIONS in inches (millimeters)						
BRACKETS (RoHS-COMPLIANT)						
TYPE	PART NUMBER	A	B	C	FIGURE NUMBER	
2 Feet	1245860035A	1.375 (34.9)	1.781 (45.2)	2.218 (56.3)	1	
3 Feet	1245860036A	2.000 (50.8)	2.500 (63.5)	2.875 (73.0)	2	
3 Feet	1245860037A	2.500 (63.5)	3.000 (76.2)	3.375 (85.7)	2	
3 Feet	1245860038A	3.000 (76.2)	3.500 (88.9)	3.875 (98.4)	2	
SCREW INSERT TERMINAL DIMENSIONS						
TERMINAL CODE	THREAD	THREAD DEPTH	HEIGHT J ± 0.032 (0.81)	DIAMETER S ± 0.010 (0.25)	DIAMETER T ± 0.010 (0.25)	NOTES
A	10-32 NF-28	0.219 (5.6)	0.063 (1.6)	0.313 (8.0)	0.438 (11.1)	All cases codes
B	10-32 NF-28	0.375 (9.5)	0.250 (6.4)	0.313 (8.0)	0.438 (11.1)	All cases codes
D	1/4-28 NF-28	0.344 (8.7)	0.093 (2.4)	0.688 (17.5)	-	C and D dia. codes only

DIMENSIONS AND AVAILABLE FORMS

SCREW INSERT TERMINALS

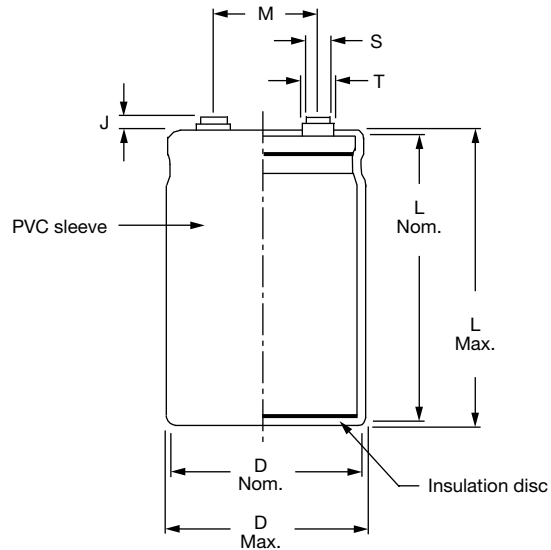
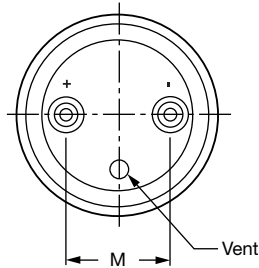

LARGE CAN BRACKETS

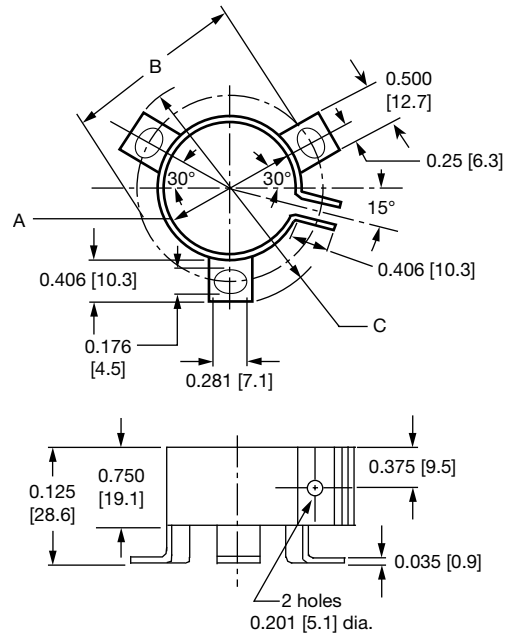
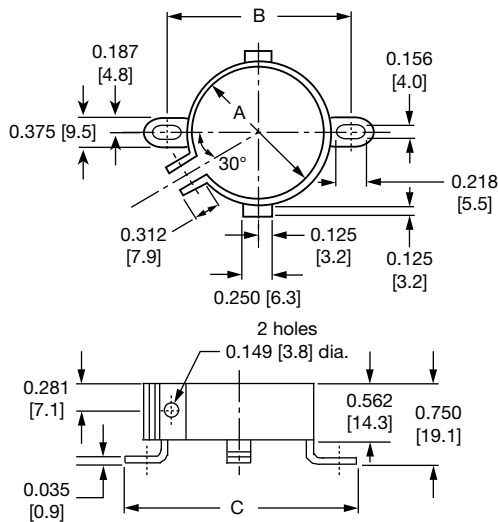

ORDERING EXAMPLE

Electrolytic capacitor 36DX series: 36DX 392 G 075 BB 2 A

DESCRIPTION	
CODE	EXPLANATION
36DX	Product type
392	Capacitance value (3900 μF)
G	Tolerance (G = - 10 %/+ 75 %; F = - 10 %/+ 50 %)
075	Voltage rating at 85 °C (75 V)
BB	Can size (see dimensions table)
2	PVC insulating sleeve
A	Terminal code (low insert 10-32 screw thread)



ELECTRICAL DATA AND ORDERING INFORMATION (original/improved ratings)		
CAPACITANCE (μF)	CASE CODE	PART NUMBER
TYPE 36D		
15 V_{DC} AT + 85 °C, SURGE = 18 V		
13 000	AC	36D133G015AC2A
25 V_{DC} AT + 85 °C, SURGE = 30 V		
2700	AA	36D272G025AA2A
5500	AB	36D552G025AB2A
40 V_{DC} AT + 85 °C, SURGE = 50 V		
5500	AC	36D552G040AC2A
8400	BB	36D842G040BB2A
12 000	BC	36D123G040BC2A
50 V_{DC} AT + 85 °C, SURGE = 65 V		
1300	AA	36D132G050AA2A
2600	AB	36D262G050AB2A
3900	AC	36D392G050AC2A
5200	AE	36D522G050AE2A
6000	BB	36D602G050BB2A
9000	BC	36D902G050BC2A
15 000	CC	36D153G050CC2A
75 V_{DC} AT + 85 °C, SURGE = 95 V		
3900	BB	36D392G075BB2A
10 000	CC	36D103G075CC2A
350 V_{DC} AT + 85 °C, SURGE = 400 V		
190	AB	36D191F350AB2A
TYPE 36DE		
10 V_{DC} AT + 85 °C, SURGE = 12 V		
23 000	AA	36DE233G010AA2A
25 V_{DC} AT + 85 °C, SURGE = 30 V		
40 000	BB	36DE403G025BB2A
40 V_{DC} AT + 85 °C, SURGE = 50 V		
24 000	BB	36DE243G040BB2A
TYPE 36DX		
15 V_{DC} AT + 85 °C, SURGE = 18 V		
7500	AA	36DX752G015AA2A
15 000	AB	36DX153G015AB2A
22 000	AC	36DX223G015AC2A
34 000	AF	36DX343G015AF2a
50 000	BC	36DX503G015BC2A
25 V_{DC} AT + 85 °C, SURGE = 30 V		
4500	AA	36DX452G025AA2A
9000	AB	36DX902G025AB2A
13 000	AC	36DX133G025AC2A
20 000	AF	36DX203G025AF2A
30 000	BC	36DX303G025BC2A
50 000	CC	36DX503G025CC2A



ELECTRICAL DATA AND ORDERING INFORMATION (original/improved ratings)		
CAPACITANCE (μF)	CASE CODE	PART NUMBER
TYPE 36DX		
30 V_{DC} AT + 85 °C, SURGE = 40 V		
4000	AA	36DX402G030AA2A
8000	AB	36DX802G030AB2A
18 000	AF	36DX183G030AF2A
26 000	BC	36DX263G030BC2A
40 V_{DC} AT + 85 °C, SURGE = 50 V		
2900	AA	36DX292G040AA2A
5800	AB	36DX582G040AB2A
8700	AC	36DX872G040AC2A
20 000	BC	36DX203G040BC2A
34 000	CC	36DX343G040CC2A
50 V_{DC} AT + 85 °C, SURGE = 65 V		
2400	AA	36DX242G050AA2A
4800	AB	36DX482G050AB2A
7200	AC	36DX722G050AC2A
11 000	AF	36DX113G050AF2A
16 000	BC	36DX163G050BC2A
24 000	BF	36DX243G050BF2A
40 000	CF	36DX403G050CF2A
41 000	DC	36DX413G050DC2A
75 V_{DC} AT + 85 °C, SURGE = 95 V		
1400	AA	36DX142G075AA2A
4200	AC	36DX422G075AC2A
10 000	BC	36DX103G075BC2A
17 000	CC	36DX173G075CC2A
100 V_{DC} AT + 85 °C, SURGE = 125 V		
1700	AB	36DX172G100AB2A
200 V_{DC} AT + 85 °C, SURGE = 250 V		
850	AC	36DX851F200AC2A
2000	BC	36DX202F200BC2A
2800	BC	36DX282F200BC2A
3400	CC	36DX342F200CC2A
7400	DF	36DX742F200DF2A
250 V_{DC} AT + 85 °C, SURGE = 300 V		
500	AB	36DX501F250AB2A
10 000	DJ	36DX103F250DJ2A
350 V_{DC} AT + 85 °C, SURGE = 400 V		
3100	DF	36DX312F350DF2A
3300	DF	36DX332F350DF2A
5100	DJ	36DX512F350DJ2A
450 V_{DC} AT + 85 °C, SURGE = 525 V		
230	AC	36DX231F450AC2A
2000	DF	36DX202F450DF2A
3100	DJ	36DX312F450DJ2A
3500	DJ	36DX352F450DJ2A



Disclaimer

ALL PRODUCT, PRODUCT SPECIFICATIONS AND DATA ARE SUBJECT TO CHANGE WITHOUT NOTICE TO IMPROVE RELIABILITY, FUNCTION OR DESIGN OR OTHERWISE.

Vishay Intertechnology, Inc., its affiliates, agents, and employees, and all persons acting on its or their behalf (collectively, "Vishay"), disclaim any and all liability for any errors, inaccuracies or incompleteness contained in any datasheet or in any other disclosure relating to any product.

Vishay makes no warranty, representation or guarantee regarding the suitability of the products for any particular purpose or the continuing production of any product. To the maximum extent permitted by applicable law, Vishay disclaims (i) any and all liability arising out of the application or use of any product, (ii) any and all liability, including without limitation special, consequential or incidental damages, and (iii) any and all implied warranties, including warranties of fitness for particular purpose, non-infringement and merchantability.

Statements regarding the suitability of products for certain types of applications are based on Vishay's knowledge of typical requirements that are often placed on Vishay products in generic applications. Such statements are not binding statements about the suitability of products for a particular application. It is the customer's responsibility to validate that a particular product with the properties described in the product specification is suitable for use in a particular application. Parameters provided in datasheets and/or specifications may vary in different applications and performance may vary over time. All operating parameters, including typical parameters, must be validated for each customer application by the customer's technical experts. Product specifications do not expand or otherwise modify Vishay's terms and conditions of purchase, including but not limited to the warranty expressed therein.

Except as expressly indicated in writing, Vishay products are not designed for use in medical, life-saving, or life-sustaining applications or for any other application in which the failure of the Vishay product could result in personal injury or death. Customers using or selling Vishay products not expressly indicated for use in such applications do so at their own risk. Please contact authorized Vishay personnel to obtain written terms and conditions regarding products designed for such applications.

No license, express or implied, by estoppel or otherwise, to any intellectual property rights is granted by this document or by any conduct of Vishay. Product names and markings noted herein may be trademarks of their respective owners.

Material Category Policy

Vishay Intertechnology, Inc. hereby certifies that all its products that are identified as RoHS-Compliant fulfill the definitions and restrictions defined under Directive 2011/65/EU of The European Parliament and of the Council of June 8, 2011 on the restriction of the use of certain hazardous substances in electrical and electronic equipment (EEE) - recast, unless otherwise specified as non-compliant.

Please note that some Vishay documentation may still make reference to RoHS Directive 2002/95/EC. We confirm that all the products identified as being compliant to Directive 2002/95/EC conform to Directive 2011/65/EU.

Vishay Intertechnology, Inc. hereby certifies that all its products that are identified as Halogen-Free follow Halogen-Free requirements as per JEDEC JS709A standards. Please note that some Vishay documentation may still make reference to the IEC 61249-2-21 definition. We confirm that all the products identified as being compliant to IEC 61249-2-21 conform to JEDEC JS709A standards.