

Ø 10 mm Film Dielectric Trimmers

TEST VOLTAGE (DC) FOR 1 MINUTE:

300 V

MAXIMUM CONTACT RESISTANCE:

10 mΩ

MINIMUM INSULATION RESISTANCE:

10 000 MΩ

CATEGORY TEMPERATURE RANGE:**PP**

- 40 to + 70 °C

PC, PTFE

- 40 to + 85 °C

CLIMATIC CATEGORY (IEC 60068):**PP**

40/070/21

PC, PTFE

40/085/21

MINIMUM STORAGE TEMPERATURE:

- 55 °C

RELATED SPECIFICATION:

IEC 60418-1 and 4

EFFECTIVE ANGLE OF ROTATION:

180° (rotation in 180° only, see "Life of Trimmer")

OPERATING TORQUE:

2 to 25 mNm

MAXIMUM AXIAL THRUST:

2 N

FEATURES

- Housing diameter 10 mm
- For a basic grid of 2.54 mm (0.1") or 2.50 mm
- Top and bottom or top adjustment
- Vertical and horizontal versions
- Round head

RoHS
COMPLIANT
APPLICATIONS

- For consumer and industrial equipment

DESCRIPTION:

The vanes of the trimmer are stacked on a sturdy plastic base. The color of the base indicates the maximum capacitance (see Electrical Data Table). The dielectric is a film of polypropylene (PP), polycarbonate (PC) or polytetrafluorethylene (PTFE), which supports the vanes in such a way that good stability is ensured and no microphony can occur.

Flux absorption between the vanes is prevented.

Cleaning with solvents is not advised.

Versions are available with either a vertical spindle, or a horizontal spindle.

Both versions have top adjustment by means of a screwdriver or trimming key and bottom adjustment by means of a key.

QUALITY LEVEL:

Sampling and data evaluation for quality level in accordance with "MIL-STD-105D" and "IEC 60410":

< 0.15 % major defects

< 0.65 % minor defects

Each capacitor is tested for minimum C_{max} and is also subjected to the full test voltage.

 C_{min}/C_{max} :

2.5/15 to 7/105 pF

RATED VOLTAGE (DC):

150 V

LIFE OF TRIMMER:

Maximum 10 cycles: rotation in 180° only (the electrical and mechanical performance is not guaranteed if rotated beyond 10 cycles)

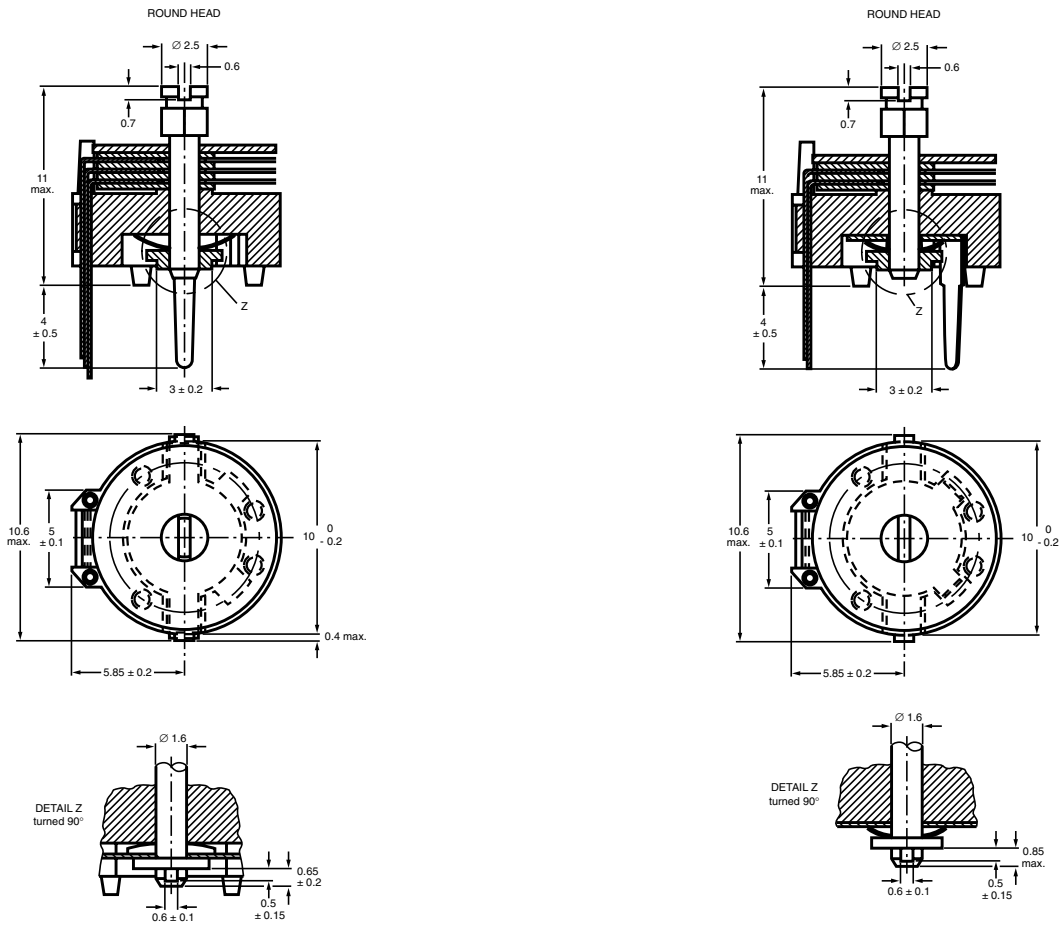

Trimmers BFC2 808 series, vertical version

Dimensions in millimeters

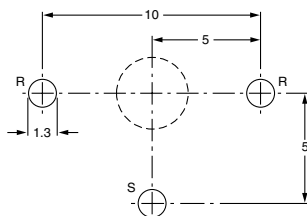

R = rotor, S = stator

The large hole is for bottom adjustment and the diameter is determined by user's requirements.

Hole pattern

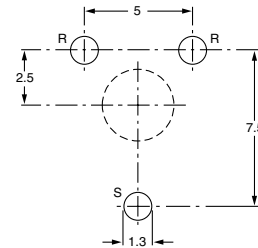

R = rotor, S = stator

Hole pattern

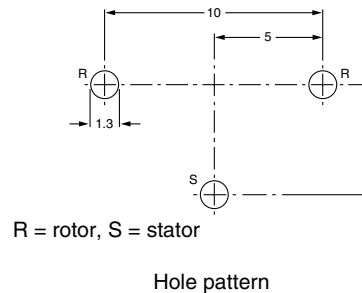
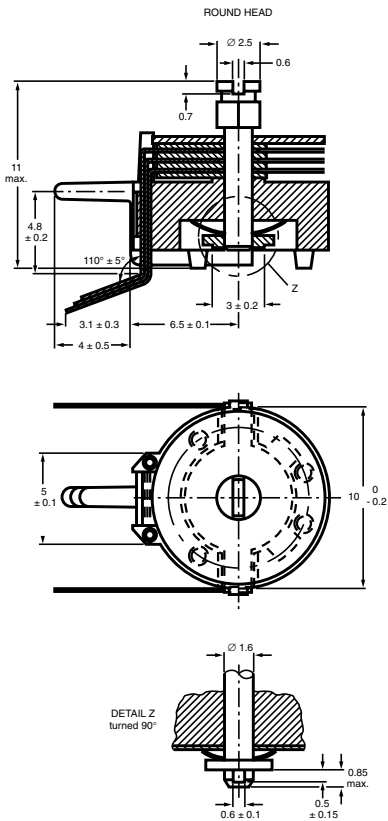

ADJUSTMENT

For top adjustment a screwdriver or trimming key can be used; for bottom adjustment a key is required as shown below

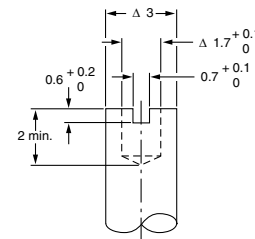

Bottom adjustment key

Trimmers BFC2 808 series, horizontal version

Dimensions in millimeters

ORDERING INFORMATION

C _{min} /C _{max} (pF)	CATALOG NUMBER BFC2 808			
	HORIZONTAL VERSION		VERTICAL VERSION	
	HOLE PATTERN 5 mm x 10 mm	HOLE PATTERN 5 mm x 10 mm	HOLE PATTERN 7.5 mm x 5 mm	
	ROUND HEAD	ROUND HEAD	ROUND HEAD	ROUND HEAD
	TOP AND BOTTOM ADJUSTMENT	TOP AND BOTTOM ADJUSTMENT		TOP ADJUSTMENT
2.5/15	61159	31159	32159	-
3/22.5	61229	31229	32229	-
5.5/40	61409	31409	32409	-
5.5/50	-	01029	01006	-
5.5/65	61659	31659	32659	01001
6/80	61809	31809	32809	-
7/105	61101	31101	32101	-
6/120	-	31121	-	-



MOUNTING

The trimmer can be mounted on printed-circuit boards with a grid of 2.50 mm or 2.54 mm and a minimum hole diameter of 1.25 mm.

PACKAGING

Bulk packaged in cardboard boxes lined with expanded plastic. For smallest packaging quantities (SPQ) see Electrical Data Table.

ELECTRICAL DATA

GUARANTEED MAX. C _{min} / MIN. C _{max} AT 200 kHz (pF)	SPINDLE	SHAPE OF HEAD	FIG.	ADJ. MODE	DIEL.	TAN δ AT C _{max} x 10 ⁻⁴		TEMP. COEFF. (10 ⁻⁶ /K)	MIN. f _{res} AT C _{max} (MHz)	COL. OF BASE	SPQ	CATALOG NUMBER BFC2
						1 MHz	100 MHz					
2.5/15	vertical	round	1	top + bottom	PP	≤ 10	≤ 25	- 200 ± 700	420	blue	800 808 31159
			2								800 808 32159
	3		700							 808 61159	
3/22.5	vertical	round	1	top + bottom	PP	≤ 10	≤ 25	- 200 ± 700	200	green	800 808 31229
			2								800 808 32229
	3		700							 808 61229	
5.5/40	vertical	round	1	top + bottom	PP	≤ 10	≤ 25	- 200 ± 400	200	grey	800 808 31409
			2								800 808 32409
	3		700							 808 61409	
5.5/50	vertical	round	1	top + bottom	PTFE	≤ 10	≤ 25	- 200 ± 400	170	yellow	800 808 01029
			2								800 808 01006
5.5/65	vertical	round	2	top	PP	≤ 10	≤ 25	- 200 ± 500	170	yellow	800 808 01001
			1								800 808 31659
	2	800 808 32659									
	3	700 808 61659									
6/80	vertical	round	1	top + bottom	PC	≤ 70	-	- 50 ± 400	170	red	800 808 31809
			2								800 808 32809
	3		700							 808 61809	
7/105	vertical	round	1	top + bottom	PC	≤ 70	-	- 50 ± 400	170	violet	800 808 31101
			2								800 808 32101
	3		700							 808 61101	
6/120	vertical	round	2	top + bottom	PC	≤ 70	-	- 50 ± 400	170	violet	800 808 31121

* ordering code for SAP system

TEST PROCEDURES AND REQUIREMENTS

IEC 60418-1 CLAUSE	IEC 60068 TEST METHOD	TEST	PROCEDURE	REQUIREMENTS
4.2		method of mounting	method A	
14		capacitance drift	after TC measurement	ΔC/C: ≤ 4.5 % for C _{max} < 40 pF; ΔC/C: ≤ 2.5 % for C _{max} ≥ 40 pF
19		thrust	axial thrust of 2 N	ΔC/C: ≤ 0.3 %
21		robustness of terminations:		
21.1	Ua	tensile	1 N	no damage
21.2	Ub	bending	1 cycle	no damage
22	Na	rapid change of temperature	1 cycle; 0.5 hours at lower and 0.5 hours at upper category temperature	ΔC/C: ≤ 1.5 %
23	T	soldering:		
	Ta	solderability	solder bath immersion 3 mm; 235 °C; 2 s	good wetting no mechanical damage
	Tb	resistance to heat	solder bath: 260 °C; 10 s	no mechanical damage
24	Eb	impact bump	4000 ± 10 bumps; 40 g; 6 ms	ΔC/C: ≤ 0.4 %; no mechanical damage

IEC 60418-1 CLAUSE	IEC 60068 TEST METHOD	TEST	PROCEDURE	REQUIREMENTS	
25	Fc	vibration	frequency 10 to 55 Hz; amplitude 0.35 mm; 1.5 hours	$\Delta C/C: \leq 0.8 \%$; no mechanical damage	
26	B	climatic sequence:		$\Delta C/C: \leq 3 \%$ for $C_{max} < 80 \text{ pF}$; $\Delta C/C: \leq 6 \%$ for $C_{max} \geq 80 \text{ pF}$	
26.1		dry heat	16 hours at upper category temperature	$\tan \delta: \leq 15 \times 10^{-4}$ for $C_{max} < 80 \text{ pF}$; $\tan \delta: \leq 80 \times 10^{-4}$ for $C_{max} \geq 80 \text{ pF}$ $R_{ins}: \geq 10\,000 \text{ M}\Omega$; rotor contact R: $\leq 10 \Omega$	
26.2		damp heat accelerated, first cycle	1 cycle; 24 hours; + 40 °C; 95 to 100 % RH	voltage proof: 300 V for 1 minute	
26.3		Aa	cold	16 hours; - 40 °C	visual examination: no mechanical damage
26.5		damp heat accelerated, remaining cycles	1 cycle; 24 hours; + 40 °C; 95 to 100 % RH	operating torque: 2 to 35 mNm	
27	Ca	damp heat steady state	21 days; + 40 °C; 90 to 95 % RH	$\Delta C/C:$ $\leq 3 \%$ for $C_{max} < 100 \text{ pF}$; $\leq 3 \%$ for $C_{max} \geq 100 \text{ pF}$ $\tan \delta: \leq 20 \times 10^{-4}$ for $C_{max} < 80 \text{ pF}$; $\tan \delta: \leq 80 \times 10^{-4}$ for $C_{max} \geq 80 \text{ pF}$ $R_{ins}: \geq 10\,000 \text{ M}\Omega$; rotor contact R: $\leq 10 \text{ m}\Omega$ voltage proof: 300 V for 1 minute visual examination: no mechanical damage operating torque: 2 to 35 mNm	
29		mechanical endurance	10 cycles Maximum 10 cycles: rotation in 180° only (the electrical and mechanical performance is not guaranteed if rotated beyond 10 cycles)	$\Delta C/C: \leq 1 \%$ $\Delta C/C$ after axial thrust: $\leq 0.4 \%$; rotor contact R: $\leq 10 \text{ m}\Omega$ voltage proof: 300 V for 1 minute visual examination: no mechanical damage operating torque: 1.5 to 37 mNm	



Disclaimer

ALL PRODUCT, PRODUCT SPECIFICATIONS AND DATA ARE SUBJECT TO CHANGE WITHOUT NOTICE TO IMPROVE RELIABILITY, FUNCTION OR DESIGN OR OTHERWISE.

Vishay Intertechnology, Inc., its affiliates, agents, and employees, and all persons acting on its or their behalf (collectively, "Vishay"), disclaim any and all liability for any errors, inaccuracies or incompleteness contained in any datasheet or in any other disclosure relating to any product.

Vishay makes no warranty, representation or guarantee regarding the suitability of the products for any particular purpose or the continuing production of any product. To the maximum extent permitted by applicable law, Vishay disclaims (i) any and all liability arising out of the application or use of any product, (ii) any and all liability, including without limitation special, consequential or incidental damages, and (iii) any and all implied warranties, including warranties of fitness for particular purpose, non-infringement and merchantability.

Statements regarding the suitability of products for certain types of applications are based on Vishay's knowledge of typical requirements that are often placed on Vishay products in generic applications. Such statements are not binding statements about the suitability of products for a particular application. It is the customer's responsibility to validate that a particular product with the properties described in the product specification is suitable for use in a particular application. Parameters provided in datasheets and/or specifications may vary in different applications and performance may vary over time. All operating parameters, including typical parameters, must be validated for each customer application by the customer's technical experts. Product specifications do not expand or otherwise modify Vishay's terms and conditions of purchase, including but not limited to the warranty expressed therein.

Except as expressly indicated in writing, Vishay products are not designed for use in medical, life-saving, or life-sustaining applications or for any other application in which the failure of the Vishay product could result in personal injury or death. Customers using or selling Vishay products not expressly indicated for use in such applications do so at their own risk. Please contact authorized Vishay personnel to obtain written terms and conditions regarding products designed for such applications.

No license, express or implied, by estoppel or otherwise, to any intellectual property rights is granted by this document or by any conduct of Vishay. Product names and markings noted herein may be trademarks of their respective owners.

Material Category Policy

Vishay Intertechnology, Inc. hereby certifies that all its products that are identified as RoHS-Compliant fulfill the definitions and restrictions defined under Directive 2011/65/EU of The European Parliament and of the Council of June 8, 2011 on the restriction of the use of certain hazardous substances in electrical and electronic equipment (EEE) - recast, unless otherwise specified as non-compliant.

Please note that some Vishay documentation may still make reference to RoHS Directive 2002/95/EC. We confirm that all the products identified as being compliant to Directive 2002/95/EC conform to Directive 2011/65/EU.

Vishay Intertechnology, Inc. hereby certifies that all its products that are identified as Halogen-Free follow Halogen-Free requirements as per JEDEC JS709A standards. Please note that some Vishay documentation may still make reference to the IEC 61249-2-21 definition. We confirm that all the products identified as being compliant to IEC 61249-2-21 conform to JEDEC JS709A standards.