

Ceramic Singlelayer Feed-Through Capacitors 400V_{DC}

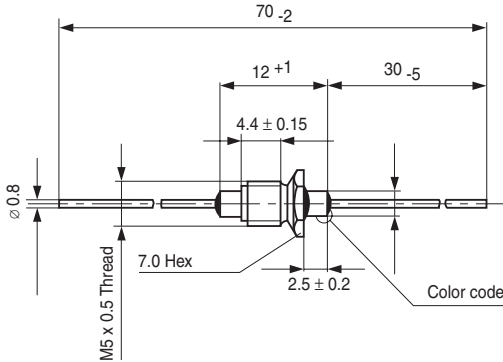

• Dimensions in mm

	L ¹ (mm)	L ² (mm)
DDLK 0307	7	39 +1
DDLK 0312	12	65 +1
DDLK 0316	16	65 +1

PERMISSIBLE POWER LOSS:

DDLK 0307: 135 mW
DDLK 0312: 135 mW
DDLK 0316: 150 mW

MARKING:

none

DESIGN:

Feed-through capacitor solderable, varnished

RATED VOLTAGE U_R:

400 V_{DC} (280 V_{RMS})

DIELECTRIC STRENGTH BETWEEN LEADS:

1250V_{DC} 1 s

DISSIPATION FACTOR tan δ:

Ceramic Class 1: see General Information
Ceramic Class 2: ≤ 25 • 10⁻³

INSULATION RESISTANCE R_{IS}:

Ceramic Class 1: ≥ 1 • 10¹⁰ Ω
Ceramic Class 2: ≥ 5 • 10⁹ Ω

CATEGORY TEMPERATURE RANGE θ_A:

Ceramic Class 1: (- 55 to + 125) °C
Ceramic Class 2: (- 25 to + 85) °C

CLIMATIC CATEGORY ACC. TO EN 60068-1:

40 / 085 / 04

PERMISSIBLE REACTIVE POWER:

DDLK 0307: 4 VAR (Class 2), 67 VAR (Class 1)
DDLK 0312: 5.4 VAR (Class 2), 90 VAR (Class 1)
DDLK 0316: 7.1 VAR (Class 2), 120 VAR (Class 1)

DIRECT CURRENT I_{DC}:

10 A

CLASS	CERAMIC DIELECTRIC	CAPACITANCE VALUES (pF)		
		DDLK 0307	DDLK 0312	DDLK 0316
1 B	P 100	1.5 to 10	to 12	to 36
	NP 0	5 to 15		
	N 075	5 to 20		
	N 150	6.8 to 20	to 62	to 100
	N 470	12 to 30		
1 F	N 750	20 to 62	to 130	to 200
	N 1500	68 to 100	to 150	to 180
2	R 700	180 to 360	to 680	to 1500
	R 2000	390 to 910	to 1600	to 3900
	R 4000	680 to 1800	to 3600	to 6800

* This series is available in both the Class 1A and Class 1B (standard)

** Class 1A only available ≥ 15 pF

CERAMIC DIELECTRIC	NOMINAL VALUE	CAPACITANCE TOLERANCE		
P 100 to N 750	< 10 pF	± 0.5 pF	± 1 pF	
	≥ 10 pF		± 10 %	± 20 %
R 700 to R 2000			- 20 + 50 %	
R 4000 to R 6000			- 20 + 50 %	- 20 + 80 %

ORDERING INFORMATION

DDLK 0307	400 V _{DC}	680 pF	- 20 + 50 %	R 2000
-----------	---------------------	--------	-------------	--------



Disclaimer

ALL PRODUCT, PRODUCT SPECIFICATIONS AND DATA ARE SUBJECT TO CHANGE WITHOUT NOTICE TO IMPROVE RELIABILITY, FUNCTION OR DESIGN OR OTHERWISE.

Vishay Intertechnology, Inc., its affiliates, agents, and employees, and all persons acting on its or their behalf (collectively, "Vishay"), disclaim any and all liability for any errors, inaccuracies or incompleteness contained in any datasheet or in any other disclosure relating to any product.

Vishay makes no warranty, representation or guarantee regarding the suitability of the products for any particular purpose or the continuing production of any product. To the maximum extent permitted by applicable law, Vishay disclaims (i) any and all liability arising out of the application or use of any product, (ii) any and all liability, including without limitation special, consequential or incidental damages, and (iii) any and all implied warranties, including warranties of fitness for particular purpose, non-infringement and merchantability.

Statements regarding the suitability of products for certain types of applications are based on Vishay's knowledge of typical requirements that are often placed on Vishay products in generic applications. Such statements are not binding statements about the suitability of products for a particular application. It is the customer's responsibility to validate that a particular product with the properties described in the product specification is suitable for use in a particular application. Parameters provided in datasheets and/or specifications may vary in different applications and performance may vary over time. All operating parameters, including typical parameters, must be validated for each customer application by the customer's technical experts. Product specifications do not expand or otherwise modify Vishay's terms and conditions of purchase, including but not limited to the warranty expressed therein.

Except as expressly indicated in writing, Vishay products are not designed for use in medical, life-saving, or life-sustaining applications or for any other application in which the failure of the Vishay product could result in personal injury or death. Customers using or selling Vishay products not expressly indicated for use in such applications do so at their own risk. Please contact authorized Vishay personnel to obtain written terms and conditions regarding products designed for such applications.

No license, express or implied, by estoppel or otherwise, to any intellectual property rights is granted by this document or by any conduct of Vishay. Product names and markings noted herein may be trademarks of their respective owners.

Material Category Policy

Vishay Intertechnology, Inc. hereby certifies that all its products that are identified as RoHS-Compliant fulfill the definitions and restrictions defined under Directive 2011/65/EU of The European Parliament and of the Council of June 8, 2011 on the restriction of the use of certain hazardous substances in electrical and electronic equipment (EEE) - recast, unless otherwise specified as non-compliant.

Please note that some Vishay documentation may still make reference to RoHS Directive 2002/95/EC. We confirm that all the products identified as being compliant to Directive 2002/95/EC conform to Directive 2011/65/EU.

Vishay Intertechnology, Inc. hereby certifies that all its products that are identified as Halogen-Free follow Halogen-Free requirements as per JEDEC JS709A standards. Please note that some Vishay documentation may still make reference to the IEC 61249-2-21 definition. We confirm that all the products identified as being compliant to IEC 61249-2-21 conform to JEDEC JS709A standards.