



Wet Tantalum Capacitors, Tantalum-Case with Glass-to-Tantalum Hermetic Seal for - 55 °C to + 125 °C Operation



FEATURES

- High energy, very high capacitance design
- All tantalum, hermetically sealed case
- Utilizes Vishay proven SuperTan® technology
- Terminations: Radial leaded
- Approved to DSCC drawing 10011

PERFORMANCE CHARACTERISTICS

Operating Temperature:

- 55 °C to + 85 °C (to + 125 °C with voltage derating)

Capacitance Tolerance:

At 120 Hz, + 25 °C ± 20 % standard

DC Leakage Current (DCL Max.):

At + 25 °C: Leakage current shall not exceed the values listed in the Standard Ratings tables.

Life Test:

Capacitors are capable of withstanding a 1000 h life test at a temperature of + 85 °C at the applicable rated DC working voltage.

ORDERING INFORMATION	
10011	-01
DSCC DRAWING NUMBER	DASH NUMBER

DEFENSE SUPPLY CENTER, COLUMBUS COLUMBUS, OHIO	DRAWING NUMBER 10011
---	-------------------------

DIMENSIONS in inches [millimeters]

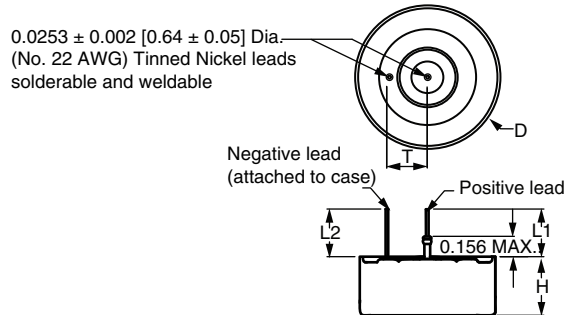

CASE CODE	D	HEIGHT	L ₂ (MIN.)	L ₁ (MIN.)	T	WEIGHT (g) (TYPICAL)
TYPE DSCC 10011						
A	1.400 ± 0.005 [35.56 ± 0.127]	0.350 ± 0.015 [8.89 ± 0.381]	0.500 [12.70]	0.500 [12.70]	0.40 ± 0.015 [10.2 ± 0.38]	48.0
B	1.400 ± 0.005 [35.56 ± 0.127]	0.488 ± 0.015 [15.60 ± 0.381]	0.500 [12.70]	0.500 [12.70]	0.40 ± 0.015 [10.2 ± 0.38]	73.0
C	1.400 ± 0.005 [35.56 ± 0.127]	0.615 ± 0.015 [15.6 ± 0.4]	0.500 [12.70]	0.500 [12.70]	0.40 ± 0.015 [10.2 ± 0.38]	95.0



STANDARD RATINGS					
CAPACITANCE (μF)	CASE CODE	MAX. ESR AT + 25 °C MAX. 1 kHz (Ω)	MAX. DCL AT + 25 °C (μA)	PART NUMBER	
25 V_{DC} AT + 85 °C; 15 V_{DC} AT + 125 °C					
24 000	A	0.060	150	10011-05	
18 000	A	0.060	150	10011-06	
48 000	B	0.045	200	10011-03	
36 000	B	0.045	200	10011-04	
72 000	C	0.035	350	10011-01	
54 000	C	0.035	300	10011-02	
50 V_{DC} AT + 85 °C; 30 V_{DC} AT + 125 °C					
8000	A	0.075	170	10011-09	
16 000	B	0.045	270	10011-08	
24 000	C	0.035	400	10011-07	
63 V_{DC} AT + 85 °C; 40 V_{DC} AT + 125 °C					
4000	A	0.100	170	10011-12	
8000	B	0.055	270	10011-11	
12 000	C	0.035	400	10011-10	
80 V_{DC} AT + 85 °C; 50 V_{DC} AT + 125 °C					
3000	A	0.100	300	10011-16	
6000	B	0.065	400	10011-15	
9000	C	0.040	500	10011-13	
100 V_{DC} AT + 85 °C; 65 V_{DC} AT + 125 °C					
1900	A	0.085	300	10011-19	
3800	B	0.065	400	10011-18	
5700	C	0.050	500	10011-17	
125 V_{DC} AT + 85 °C; 85 V_{DC} AT + 125 °C					
1100	A	0.100	300	10011-22	
2200	B	0.085	400	10011-21	
3300	C	0.075	500	10011-20	

PERFORMANCE CHARACTERISTICS OF HIGH ENERGY CAPACITORS

ELECTRICAL PERFORMANCE CHARACTERISTICS	
ITEM	PERFORMANCE CHARACTERISTICS
Operating temperature range	- 55 °C to + 85 °C (to + 125 °C with voltage derating)
Capacitor tolerance	$\pm 20\%$ at 120 Hz
ESR	Limits per Standard Ratings table
DC leakage current (DCL max.)	At 25 °C the leakage current shall not exceed values listed in the Standard Rating table.
Reverse voltage	No continuous reverse voltage permitted
Surge voltage	The test shall be at 1000 cycles at 110 % of rated voltage at 85 °C. A cycle consists of a 30 s charge and a 330 s discharge through 100 Ω resistor.
Life test at + 85 °C	1000 h at + 85 °C



ENVIRONMENTAL CHARACTERISTICS		
ITEM	TEST AND CONDITIONS	COMMENTS
Hermeticity	MIL-STD-202, method 112 C/IIIa	The capacitor shall be hermetically sealed such that the case does not leak electrolyte or vent any gas when exposed to a vacuum.
Moisture resistance	MIL-STD-202, method 106	6 V polarity
Altitude	MIL-STD-202, method 105 C, test condition D	100 000 feet test

MECHANICAL PERFORMANCE CHARACTERISTICS		
ITEM	TEST AND CONDITIONS	COMMENTS
Thermal shock	MIL-STD-202, method 107 G	Test condition A
Shock	MIL-STD-202, method 213 B test condition G	11 ms, 50 g
Vibration - high frequency	MIL-STD-202, method 204 D test condition D	12 sweeps/axis, 20 g peak
Vibration - random	MIL-STD-202, method 214 A test condition I, Letter D	1.5 h/axis, 12 g
Resistance to solder heat	MIL-STD-202, method 210 F	The capacitor must withstand solder dipping of the terminals at 260 °C for 10 s. The capacitor must not be visibly damaged and the electrical characteristics must not be affected.
Solderability	MIL-STD-202, method 208	
Terminal strength	MIL-STD-202, method 211 A	The capacitor terminals must withstand a 5 pound pull test for 5 s to 10 s. The capacitor must not be visibly damaged and the electrical characteristics must not be affected.
Resistance to solvents	MIL-STD-202, method 215 J	The capacitor shall be permanently and legibly marked on the circumference of the case. The markings shall be resistant to solvents.
Weight (mass)		See dimensions table

DSCC 10011 MOUNTING OPTIONS

The DSCC 10011 capacitor can be mounted with many commercially available methods. Vishay offers the optional mounting hardware outlined below.

THROUGH-HOLE

If mounted through-hole, the glass-to-metal seal must be protected from potential mounting and application stress. The HE3 can be mounted termination down through the HE3 SPC001 spacer into the PCB. The proper size bracket HE3BKT00* can then be utilized to hold the DSCC 10011 rigidly to the PCB.

TERMINATIONS UP

If mounted with terminations facing up for attachment to wiring, the spacer is not needed. The DSCC 10011 can be reverse with terminations facing upward through the center of the HE3BKT00* bracket, which is then mounted through the PCB.

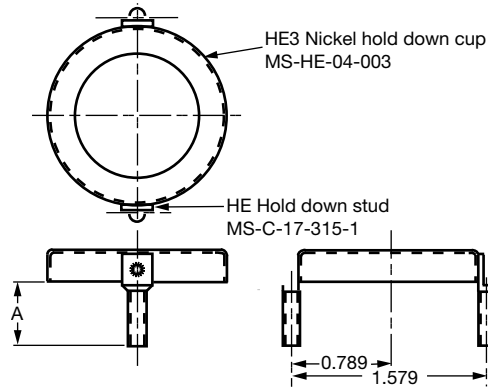

Notes

- Spot weld, 2 places
- Mounting bolt:
 1. Material - Stainless steel
 2. Thread - 6-32 NC-2A

PART NUMBER ⁽¹⁾	STUD	A ± 0.010
HE3BKT001	HE3A	0.391
HE3BKT002	HE3B	0.518
HE3BKT003	HE3C	0.605
HE3BKT004	HE3A W/spacer	0.572
HE3BKT005	HE3B W/spacer	0.699
HE3BKT006	HE3C W/spacer	0.831

Note

⁽¹⁾ The part numbers shown are for ordering the mounting bracket and/or spacer. The DSCC 10011 capacitor must be ordered separately using the correct part number as outlined in Ordering Information and in the Standard Ratings table.

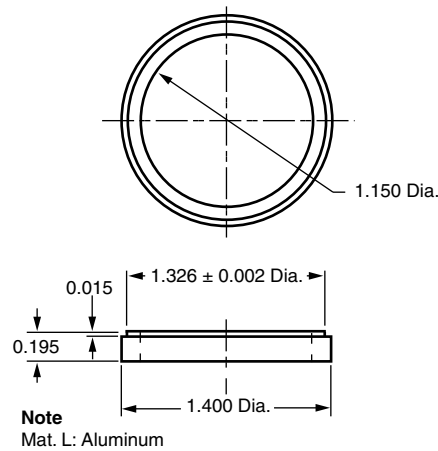

PART NUMBER ⁽¹⁾
HE3SPC001

Note

⁽¹⁾ The part numbers shown are for ordering the mounting bracket and/or spacer. The HE3 capacitor must be ordered separately using the correct part number as outlined in Ordering Information and in the Standard Ratings table.



Disclaimer

ALL PRODUCT, PRODUCT SPECIFICATIONS AND DATA ARE SUBJECT TO CHANGE WITHOUT NOTICE TO IMPROVE RELIABILITY, FUNCTION OR DESIGN OR OTHERWISE.

Vishay Intertechnology, Inc., its affiliates, agents, and employees, and all persons acting on its or their behalf (collectively, "Vishay"), disclaim any and all liability for any errors, inaccuracies or incompleteness contained in any datasheet or in any other disclosure relating to any product.

Vishay makes no warranty, representation or guarantee regarding the suitability of the products for any particular purpose or the continuing production of any product. To the maximum extent permitted by applicable law, Vishay disclaims (i) any and all liability arising out of the application or use of any product, (ii) any and all liability, including without limitation special, consequential or incidental damages, and (iii) any and all implied warranties, including warranties of fitness for particular purpose, non-infringement and merchantability.

Statements regarding the suitability of products for certain types of applications are based on Vishay's knowledge of typical requirements that are often placed on Vishay products in generic applications. Such statements are not binding statements about the suitability of products for a particular application. It is the customer's responsibility to validate that a particular product with the properties described in the product specification is suitable for use in a particular application. Parameters provided in datasheets and/or specifications may vary in different applications and performance may vary over time. All operating parameters, including typical parameters, must be validated for each customer application by the customer's technical experts. Product specifications do not expand or otherwise modify Vishay's terms and conditions of purchase, including but not limited to the warranty expressed therein.

Except as expressly indicated in writing, Vishay products are not designed for use in medical, life-saving, or life-sustaining applications or for any other application in which the failure of the Vishay product could result in personal injury or death. Customers using or selling Vishay products not expressly indicated for use in such applications do so at their own risk. Please contact authorized Vishay personnel to obtain written terms and conditions regarding products designed for such applications.

No license, express or implied, by estoppel or otherwise, to any intellectual property rights is granted by this document or by any conduct of Vishay. Product names and markings noted herein may be trademarks of their respective owners.

Material Category Policy

Vishay Intertechnology, Inc. hereby certifies that all its products that are identified as RoHS-Compliant fulfill the definitions and restrictions defined under Directive 2011/65/EU of The European Parliament and of the Council of June 8, 2011 on the restriction of the use of certain hazardous substances in electrical and electronic equipment (EEE) - recast, unless otherwise specified as non-compliant.

Please note that some Vishay documentation may still make reference to RoHS Directive 2002/95/EC. We confirm that all the products identified as being compliant to Directive 2002/95/EC conform to Directive 2011/65/EU.

Vishay Intertechnology, Inc. hereby certifies that all its products that are identified as Halogen-Free follow Halogen-Free requirements as per JEDEC JS709A standards. Please note that some Vishay documentation may still make reference to the IEC 61249-2-21 definition. We confirm that all the products identified as being compliant to IEC 61249-2-21 conform to JEDEC JS709A standards.