

High Voltage Disc Capacitors, 20 kV_{DC} Screw Mounting, Class 2 Ceramic



QUICK REFERENCE DATA	
DESCRIPTION	VALUE
Type	HPC HPD
Ceramic Class	2
Ceramic Dielectric	R2000H
Voltage (V _p)	20 000
Min. Capacitance (pF)	350
Max. Capacitance (pF)	5000
Mounting	Screw mounting

MATERIAL

Capacitor elements made from class 2 ceramic dielectric with noble metal electrodes.

Connection terminals: Thread terminal, brass, silver plated

Allowable torque: 5.0 Nm (44 lbf · in)

FINISH

The capacitor body of the HPD type is completely protective lacquered. The HPC type feature a coating made from silicone elastomer to minimize the adverse effect of moisture, dust and other impurities in the working environment.

MARKING

Capacitance value and tolerance, manufacturer logo.

FEATURES

- High reliability
- Wide range of capacitance values

APPLICATIONS

HPC and HPD high voltage capacitors made from class 2-ceramic dielectric can be used as coupling and bypass capacitors where low power ratings are required and larger capacitance changes with temperature can be tolerated.

CAPACITANCE RANGE

350 pF to 5.0 nF

CAPACITANCE TOLERANCE

± 20 %

CERAMIC DIELECTRIC

R2000H (Z5U)

RATED VOLTAGE

20 kV_{DC} or 15 kV_{RMS} (up to 120 Hz)

DIELECTRIC STRENGTH TEST

25 kV_{RMS}, 50 Hz, 5 minutes

DISSIPATION FACTOR

Max. 0.5 % (1 MHz)

INSULATION RESISTANCE

Min. 50 000 MΩ (at 25 °C)

OPERATING TEMPERATURE RANGE

- 25 °C to + 85 °C

SAP PART NUMBER, ELECTRICAL AND DIMENSIONAL DATA

PART NUMBER	CERAMIC	CAPACITANCE VALUES (pF)	RATED VOLTAGE ⁽¹⁾ (kV _{DC})	RATED VOLTAGE ⁽¹⁾ (kV _{AC})	RATED RF-CURRENT ⁽²⁾ (A _{RMS})	D ₁ mm (inch)	D ₂ max. mm (inch)
TYPE HPC							
HPC050WP35138AX1	R2000H (Z5U)	350	20	(15 kV _{RMS} up to 120 Hz)	6.0 max.		50 (1.97)
HPC050WP50138AX1		500					
HPC050WP75138AX1		750					
HPC050WP10238AX1		1000					
HPC060WP15238AX1		1500					60 (2.36)
HPC060WP20238AX1		2000					
HPC070WP30238AX1		3000					
HPC090WP50238AX1		5000					
TYPE HPD							
HPD021WP35138AX1	R2000H (Z5U)	350	20	(15 kV _{RMS} up to 120 Hz)	6.0 max.	21 (0.83)	
HPD025WP50138AX1		500				25 (0.98)	
HPD030WP75138AX1		750				30 (1.18)	
HPD035WP10238AX1		1000				35 (1.38)	
HPD043WP15238AX1		1500				43 (1.69)	
HPD050WP20238AX1		2000				50 (1.97)	
HPD059WP30238AX1		3000				59 (2.32)	
HPD075WP50238AX1		5000				75 (2.95)	

Notes

- (1) The type HPD must be operated in a high insulation environment, e.g. oil or inert gas. When operate this type in free air the rated voltage must be reduced to 7.0 kV_{DC}.
- (2) To an max. ambient temperature + 60 °C

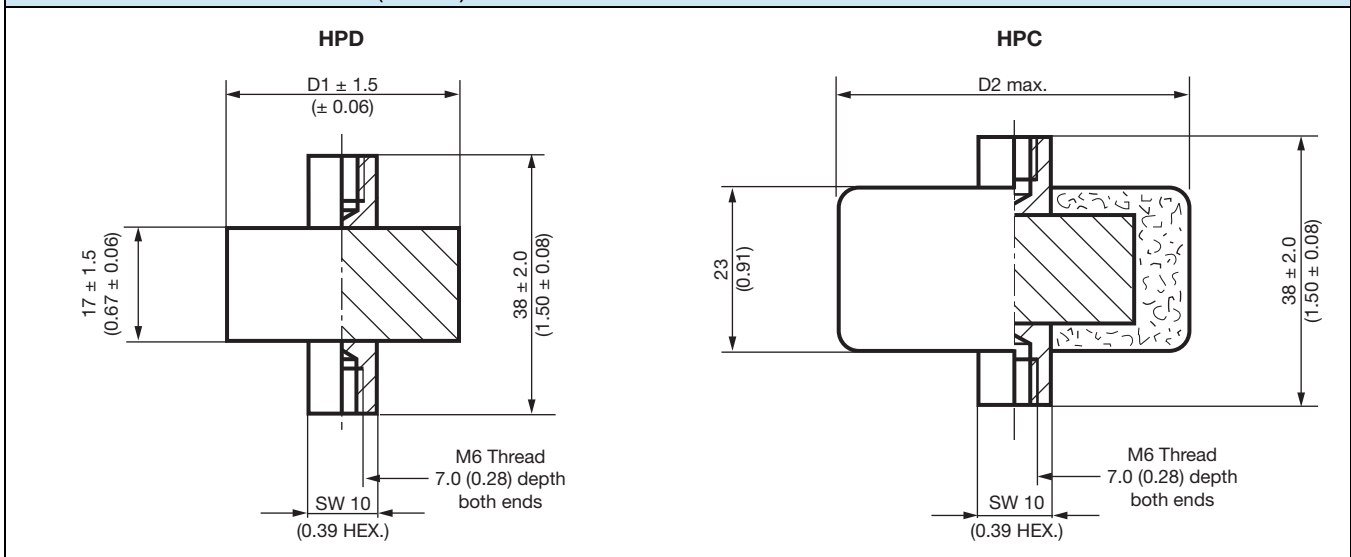
DIMENSIONS in millimeters (inches)



MOUNTING GUIDELINES

- Avoid installation in which too much torque is applied to the capacitor elements. Screw torque limit must be 5.0 Nm (44 lbf · in.)
- Do not use screws whose thread is longer than specified in the datasheet
- The capacitor elements must not be used as a mechanical support for other devices or components

CERAMIC CHARACTERISTICS (TYPICAL)

CAPACITANCE CHANGE VS. TEMPERATURE

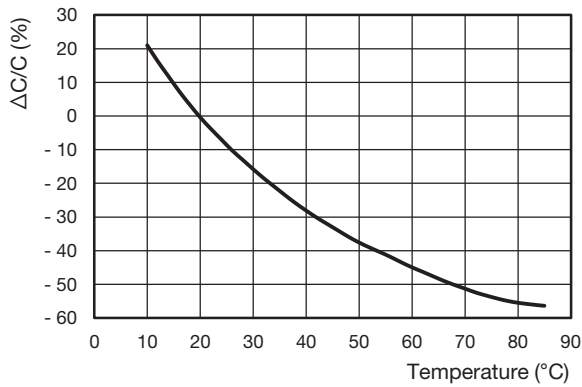

DC VOLTAGE DEPENDENCE OF CAPACITANCE

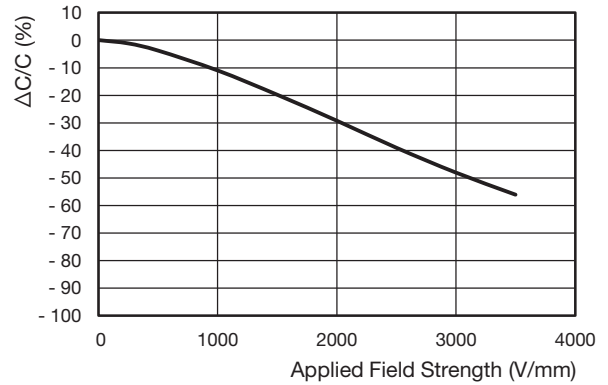



Disclaimer

ALL PRODUCT, PRODUCT SPECIFICATIONS AND DATA ARE SUBJECT TO CHANGE WITHOUT NOTICE TO IMPROVE RELIABILITY, FUNCTION OR DESIGN OR OTHERWISE.

Vishay Intertechnology, Inc., its affiliates, agents, and employees, and all persons acting on its or their behalf (collectively, "Vishay"), disclaim any and all liability for any errors, inaccuracies or incompleteness contained in any datasheet or in any other disclosure relating to any product.

Vishay makes no warranty, representation or guarantee regarding the suitability of the products for any particular purpose or the continuing production of any product. To the maximum extent permitted by applicable law, Vishay disclaims (i) any and all liability arising out of the application or use of any product, (ii) any and all liability, including without limitation special, consequential or incidental damages, and (iii) any and all implied warranties, including warranties of fitness for particular purpose, non-infringement and merchantability.

Statements regarding the suitability of products for certain types of applications are based on Vishay's knowledge of typical requirements that are often placed on Vishay products in generic applications. Such statements are not binding statements about the suitability of products for a particular application. It is the customer's responsibility to validate that a particular product with the properties described in the product specification is suitable for use in a particular application. Parameters provided in datasheets and/or specifications may vary in different applications and performance may vary over time. All operating parameters, including typical parameters, must be validated for each customer application by the customer's technical experts. Product specifications do not expand or otherwise modify Vishay's terms and conditions of purchase, including but not limited to the warranty expressed therein.

Except as expressly indicated in writing, Vishay products are not designed for use in medical, life-saving, or life-sustaining applications or for any other application in which the failure of the Vishay product could result in personal injury or death. Customers using or selling Vishay products not expressly indicated for use in such applications do so at their own risk. Please contact authorized Vishay personnel to obtain written terms and conditions regarding products designed for such applications.

No license, express or implied, by estoppel or otherwise, to any intellectual property rights is granted by this document or by any conduct of Vishay. Product names and markings noted herein may be trademarks of their respective owners.

Material Category Policy

Vishay Intertechnology, Inc. hereby certifies that all its products that are identified as RoHS-Compliant fulfill the definitions and restrictions defined under Directive 2011/65/EU of The European Parliament and of the Council of June 8, 2011 on the restriction of the use of certain hazardous substances in electrical and electronic equipment (EEE) - recast, unless otherwise specified as non-compliant.

Please note that some Vishay documentation may still make reference to RoHS Directive 2002/95/EC. We confirm that all the products identified as being compliant to Directive 2002/95/EC conform to Directive 2011/65/EU.

Vishay Intertechnology, Inc. hereby certifies that all its products that are identified as Halogen-Free follow Halogen-Free requirements as per JEDEC JS709A standards. Please note that some Vishay documentation may still make reference to the IEC 61249-2-21 definition. We confirm that all the products identified as being compliant to IEC 61249-2-21 conform to JEDEC JS709A standards.