

MULTILAYER CERAMIC CAPACITORS EPOXY COATED RADIAL TYPE

APPLICATION

Construction

NPO : Temperature compensation type, have little or no change in capacitance with variation in temperature. Hence, they are used in radio-frequency oscillators, precision timing circuits, ultra stable amplifiers, etc.

X7R : Temperature stable type for by-pass and decoupling in radio and television receivers, computers servo systems. Audio tone, and coupling, etc., where moderate capacitance variations are permissible and dissipation factor is not critical.

Z5U/Y5V : General type for by-pass and filtering applications.

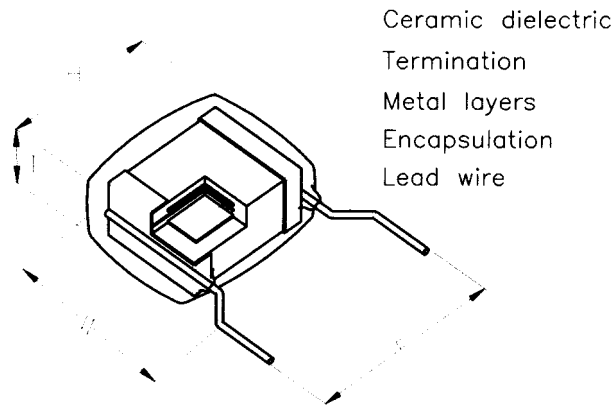

1. LEAD SHAPE :

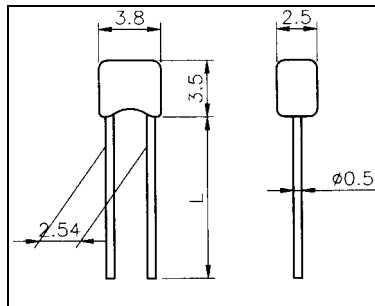
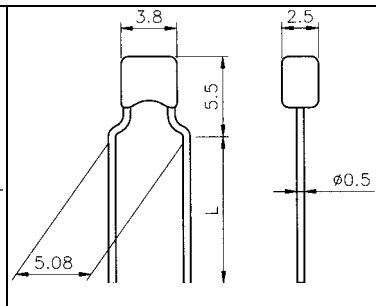
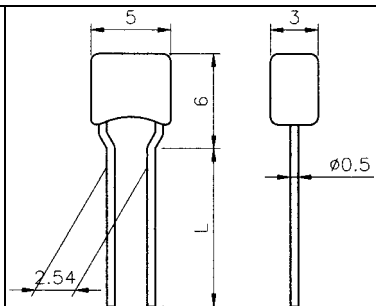
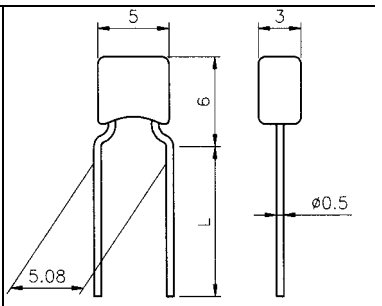
			
R15 L	R15 H	R20 Y	R20 H

2. LEAD SPACE (F)

CODE	LEAD SPACE (mm/inch)	
2	2.54±0.8	0.1±0.032
5	5.08±0.8	0.2±0.032

3. LEAD LENGTH (L)

CODE	LEAD LENGTH	REMARK
6	6mm±1mm	SPECIFIED LEAD LENGTH UPON
9	9mm±1mm	
L	25.4mm min	

4. BODY SIZE & DIMENSION

Size code	Lead style available	Capacitance Range (PF)				Dimensions (mm)				
		NPO	X7R	Z5U	Y5V	H max	W max	T max.	d±0.05	F±0.08
R15	L	1~1,000	330~100,000	1,000~220,000	10,000~330,000	3.8	3.8	2.5	0.5	2.54
	H					3.8	3.8	2.5	0.5	5.08
R20	Y	1,000~6,800	100,000~1,000,000	220,000~1,500,000	330,000~4,700,000	5.0	6.0	3.0	0.5	2.54
	H					5.0	6.0	3.0	0.5	5.08

MULTILAYER CERAMIC CAPACITORS EPOXY COATED RADIAL TYPE

Part Number Code Designation

<u>R15</u>	<u>Z</u>	<u>104</u>	<u>M</u>	<u>1H</u>	<u>L</u>	<u>5</u>	<u>L</u>
SIZE	T.C	Capacitance-Code	Tolerance	Voltage	Lead shape	Lead space	Package-Lead-length
R15 R20	N=NPO W=X7R Z=Z5U Y=Y5V	Two significant digits + NO. of zeros. Example 100=10pf 101=100pf 102=1000pf 223=22000pf 104=100000pf	G=±2% J=±5% K=±10% M=±20% Z=+80/-20%	1C=16V 1E=25V 1H=50V 2A=100V	L=Straight Y=Inside Crimp H=High seated	2=2.54±0.8 5=5.08±0.8 (mm)	R=Tape/Reel B=Tape/Box 6=6±1mm 9=9±1mm L=25.4mm(min)

TYPICAL PERFORMANCE CHARACTERISTICS

1. TEMPERATURE CHARACTERISTICS SPECIFICATIONS

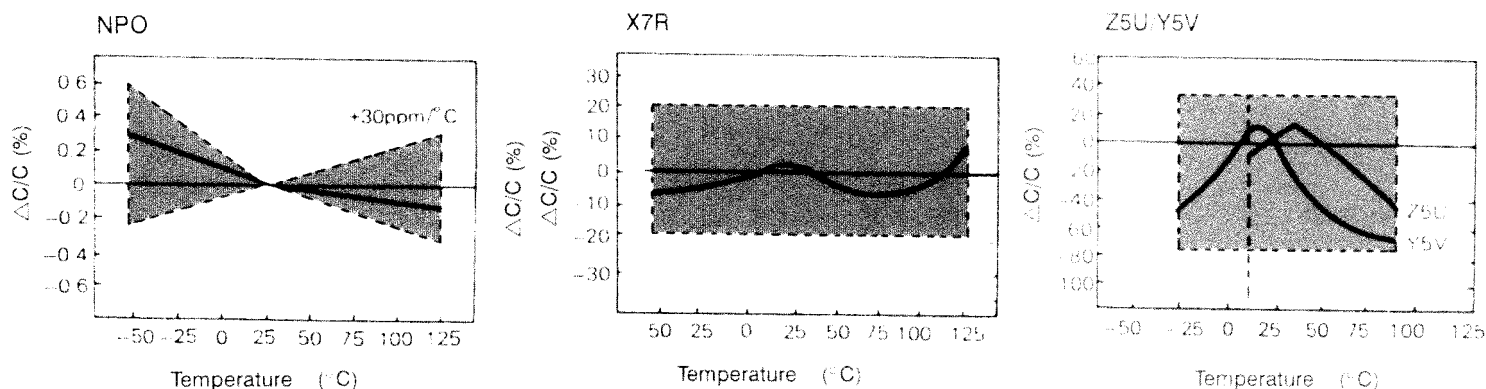

2. SPECIFICATIONS

Temperature coefficient

NPO: ±30PPM/°C, -55°C to +125°C
 X7R: ±15%, -55°C to +125°C
 Z5U: +22%, -56%, +10°C to +85°C
 Y5V: +22%, -82%, -30°C to +85°C

Capacitance test 25°C

NPO: 1 VRMS max at 1 KHz
 (1 MHz for 100pF or less)
 X7R: 1 VRMS max at 1 KHz
 Z5U: 1 VRMS max at 1 KHz
 Y5V: 1 VRMS max at 1 KHz

Dissipation Factor 25°C

NPO: 0.15% max at 1KHz, 1VRMS max
 (1 MHz for 100pF or less)
 X7R: 2.5% max at 1KHz, 1VRMS max
 Z5U: 5% max at 1KHz, 1VRMS max
 Y5V: 5% max at 1KHz, 1VRMS max

Dielectric strength 25°C (Flash Test)

- NPO and X7R: 300% rated voltage for 5 seconds with 50 mA. max charging current.
- Z5U and Y5V: 250% rated voltage for 5 seconds with 50 mA. max charging current

Life Test (1000 hrs)

NPO: ≤±3% at 200% rated voltage, 125°C
 X7R: ≤±3% at 200% rated voltage, 125°C
 Z5U: ≤±3% at 200% rated voltage, 85°C
 Y5V: ≤±3% at 200% rated voltage, 85°C

Insulation Resistance 25°C

- NPO and X7R: 100GΩ or 1000MΩ-MFD whichever is less
- Z5U and Y5V: 10GΩ or 100MΩ-MFD whichever is less