

## Ceramic Singlelayer Tubular Capacitors 160V<sub>DC</sub>

**DESIGN:**

Tubular capacitor completely lacquered (RDLL)  
 Tubular capacitor with brown phenol resin coating, impregnated (RDLT)

**RATED VOLTAGE U<sub>R</sub>:**

160V<sub>DC</sub> (110V<sub>RMS</sub>)

**DIELECTRIC STRENGTH BETWEEN LEADS:**

480V<sub>DC</sub> 1s

**DISSIPATION FACTOR tan δ:**

Ceramic Class 1: see General Information  
 Ceramic Class 2:  $\leq 25 \cdot 10^{-3}$

**INSULATION RESISTANCE R<sub>IS</sub>:**

Ceramic Class 1:  $\geq 1 \cdot 10^{10} \Omega$   
 Ceramic Class 2:  $\geq 5 \cdot 10^9 \Omega$

**CATEGORY TEMPERATURE RANGE  $\vartheta_A$ :**

Ceramic Class 1: (- 55 to + 125)°C  
 Ceramic Class 2: (- 25 to + 85)°C

**CLIMATIC CATEGORY ACC. TO EN 60068-1:**

RDLL 40 / 085 / 21  
 RDLT 55 / 085 / 56

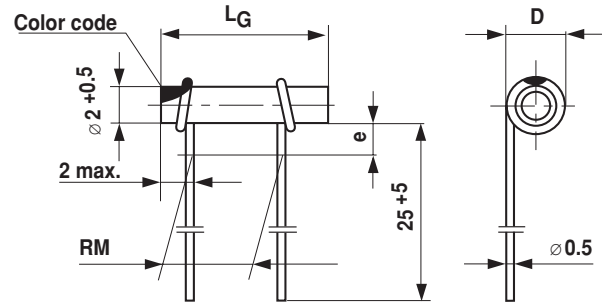

• Dimensions in mm

	RDLL	RDLT
Coating extension e	2 max.	3 max.
Overall length L <sub>G</sub>	L <sup>+1</sup> max.	L <sup>+2</sup> max.
Overall diameter D	3.5 max.	4.5 max.

**MARKING:**

Capacitance value,  
 Tolerance letter (RDL. 0210 to 0216 only)  
 Rated Voltage (RDL. 0216 only)  
 Ceramic dielectric colour code

CLASS	CERAMIC DIELECTRIC	CAPACITANCE VALUES (pF) AT NOMINAL TUBE LENGTH L (mm)				
		8 (0208)	10 (0210)	12 (0212)	14 (0214)	16 (0216)
1B	P 100	2.2 to 11	to 18	to 24	to 30	to 36
	NP 0	9.1 to 28	to 39	to 51	to 62	to 75
	N 150	10 to 39	to 56	to 75	to 100	to 120
	N 470	13 to 56	to 82	to 100	to 120	to 150
	N 750	24 to 82	to 120	to 150	to 180	to 220
2	R 700	180 to 560	to 680	to 910	to 1200	to 1500
	R 2000	620 to 1200	to 2000	to 2700	to 3600	to 4300
	R 4000	1000 to 2700	to 3600	to 5100	to 6800	to 8200
	R 6000	2700 to 4700	to 6800	to 8200	to 10000	to 12000
Lead spacing RM (mm)		5 ± 0.7	5 ± 0.7	7.5 ± 0.7	7.5 ± 0.7	7.5 ± 0.7

CERAMIC DIELECTRIC	NOMINAL VALUE	CAPACITANCE TOLERANCE			
P 100 to N 750	< 10pF	± 0.25pF	± 0.5pF	± 1pF	± 2pF
	≥ 10pF	± 2.5%	± 5%	± 10%	± 20%
R 700 to R 2000		± 10%	± 20%	- 20 + 50%	
R 4000 to R 6000			± 20%	- 20 + 50%	-20 + 80%

**ORDERING INFORMATION**

RDLL 0216	160V <sub>DC</sub>	12000pF	± 20%	R 6000
-----------	--------------------	---------	-------	--------

Vishay Draloric

**Ceramic Singlelayer Tubular Capacitors 400V<sub>DC</sub>**

**DESIGN:**

Tubular capacitor completely lacquered (RDLL)  
 Tubular capacitor with brown phenol resin coating, impregnated (RDLT)

**RATED VOLTAGE U<sub>R</sub>:**

400V<sub>DC</sub> (280V<sub>RMS</sub>)

**DIELECTRIC STRENGTH BETWEEN LEADS:**

1250V<sub>DC</sub> 1s

**DISSIPATION FACTOR tan δ:**

Ceramic Class 1: see General Information  
 Ceramic Class 2:  $\leq 25 \cdot 10^{-3}$

**INSULATION RESISTANCE R<sub>IS</sub>:**

Ceramic Class 1:  $\geq 1 \cdot 10^{10} \Omega$   
 Ceramic Class 2:  $\geq 5 \cdot 10^9 \Omega$

**CATEGORY TEMPERATURE RANGE  $\vartheta_A$ :**

Ceramic Class 1: (- 55 to + 125)°C  
 Ceramic Class 2: (- 25 to + 85)°C

**CLIMATIC CATEGORY ACC. TO EN 60068-1:**

RDLL 40 / 085 / 21  
 RDLT 55 / 085 / 56

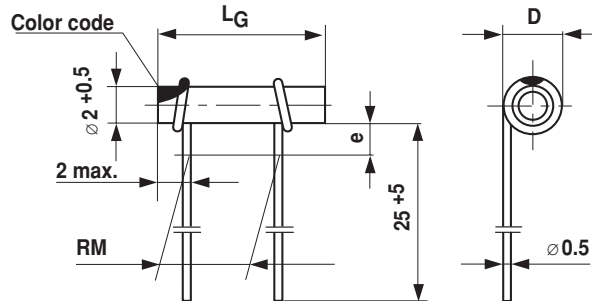

• Dimensions in mm

	<b>RDLL</b>	<b>RDLT</b>
Coating extension e	2 max.	3 max.
Overall length L <sub>G</sub>	L <sup>+1</sup> max.	L <sup>+2</sup> max.
Overall diameter D	3.5 max.	4.5 max.

**MARKING:**

Capacitance value, Tolerance letter,  
 Rated Voltage (RDL. 0216 & 0220 only)  
 Ceramic dielectric color code

CLASS	CERAMIC DIELECTRIC	CAPACITANCE VALUES (pF) AT NOMINAL TUBE LENGTH L (mm)				
		10 (0210)	12 (0212)	14 (0214)	16 (0216)	20 (0220)
1B	P 100	3.9 to 12	to 18	to 24	to 30	to 43
	NP 0	9.1 to 20	to 30	to 43	to 56	to 82
	N 033	9.1 to 22	to 39	to 51	to 62	to 91
	N 075	10 to 27	to 43	to 56	to 68	to 91
	N 150	10 to 30	to 47	to 62	to 82	to 110
	N 220	10 to 33	to 51	to 75	to 91	to 130
	N 330	12 to 39	to 56	to 82	to 100	to 140
	N 470	16 to 47	to 68	to 91	to 120	to 160
2	N 750	27 to 75	to 120	to 160	to 200	to 270
	R 700	180 to 300	to 510	to 680	to 910	to 1200
	R 1400	470 to 820	to 1200	to 1600	to 2000	to 3000
	R 2000	620 to 910	to 1500	to 2100	to 2700	to 3900
	R 4000	1000 to 1800	to 2700	to 4300	to 5600	to 7500
	R 6000	1800 to 3300	to 4700	to 6800	to 8200	to 12000
Lead spacing RM (mm)		5 ± 0.7	5 ± 0.7	7.5 ± 0.7	10 ± 0.7	15 ± 0.7

CERAMIC DIELECTRIC	NOMINAL VALUE	CAPACITANCE TOLERANCE			
P100 to N 750	< 10pF	± 0.25pF	± 0.5pF	± 1pF	± 2pF
	≥ 10 to 24pF	± 2%	± 5%	± 10%	± 20%
	> 24pF	± 1%	± 2%	± 5%	± 10%± 20%
R 700 to R 2000		± 10%	± 20%	- 20 + 50%	
R 4000 to R 6000			± 20%	- 20 + 50%	- 20 + 80%

<b>ORDERING INFORMATION</b>				
RDLL 0220	400V <sub>DC</sub>	270pF	± 20%	N 750



## Disclaimer

All product specifications and data are subject to change without notice.

Vishay Intertechnology, Inc., its affiliates, agents, and employees, and all persons acting on its or their behalf (collectively, "Vishay"), disclaim any and all liability for any errors, inaccuracies or incompleteness contained herein or in any other disclosure relating to any product.

Vishay disclaims any and all liability arising out of the use or application of any product described herein or of any information provided herein to the maximum extent permitted by law. The product specifications do not expand or otherwise modify Vishay's terms and conditions of purchase, including but not limited to the warranty expressed therein, which apply to these products.

No license, express or implied, by estoppel or otherwise, to any intellectual property rights is granted by this document or by any conduct of Vishay.

The products shown herein are not designed for use in medical, life-saving, or life-sustaining applications unless otherwise expressly indicated. Customers using or selling Vishay products not expressly indicated for use in such applications do so entirely at their own risk and agree to fully indemnify Vishay for any damages arising or resulting from such use or sale. Please contact authorized Vishay personnel to obtain written terms and conditions regarding products designed for such applications.

Product names and markings noted herein may be trademarks of their respective owners.