

RF Power Barrel Capacitors, Class 1 Ceramic



QUICK REFERENCE DATA		
DESCRIPTION	VALUE	
Ceramic Class	1	
Ceramic Dielectric	R7, R16, R42, R85	
Type	TOF 016010 TOS 016010	TOF 025016 TOS 025016
Voltage (V _p)	5000	9000
Min. Capacitance (pF)	1.5	2.0
Max. Capacitance (pF)	50	100
Mounting	Tag mounting or screw mounting	

MATERIAL

Capacitor elements made from Class 1 ceramic dielectric with noble metal electrodes.

Connection terminals:

- Axial copper tags, silver plated (Style TOF...)
- Thread terminal, brass, silver plated (Style TOS...)

Allowable torque: M5 thread 3.5 Nm (31 lbf in)
M6 thread 5.0 Nm (44 lbf in)

FINISH

Capacitor body completely protective lacquered

MARKING

Type designator, capacitance value and tolerance, rated peak voltage, ceramic material code, production date code, manufacturer logo

FEATURES

- Small size
- Geometry minimizes inductance, optimizes voltage withstand and maximizes heat radiation
- Available with thread terminals or axial mounting tags

APPLICATIONS

- Industrial and medical RF power supply
- Small broadcasting equipment
- Antenna couplers
- Induction heating equipment

CAPACITANCE RANGE

1.5 pF to 100 pF

CAPACITANCE TOLERANCE

< 10 pF: ± 2 pF; ± 1 pF; ± 0.5 pF
≥ 10 pF: ± 20 %; ± 10 %; ± 5 %

CERAMIC DIELECTRICS

- R7 (TCC + 100 ppm/K)
- R16 (TCC + 100 ppm/K)
- R42 (TCC - 250 ppm/K)
- R85 (TCC - 750 ppm/K)

RATED VOLTAGE

- 5.0 kV_p
- 9.0 kV_p

DIELECTRIC STRENGTH TEST

200 % of rated AC voltage (50 Hz, 5 minutes)

DISSIPATION FACTOR

- R7: Max. 0.07 % (1 MHz)
- R16: Max. 0.04 % (1 MHz)
- R42, R85: Max. 0.05 % (1 MHz)

INSULATION RESISTANCE

Min. 100 000 MΩ (at 25 °C)

OPERATING TEMPERATURE RANGE

- 55 °C to + 100 °C



SAP PART NUMBER AND ELECTRICAL DATA							
PART NUMBER	CERAMIC	CAP. VALUES (pF)	RATED VOLTAGE (kV _P)	RATED POWER ⁽¹⁾ (kvar)	RATED CURRENT (A _{RMS})		
TYPE TOS 016010							
BS016010BE915##BF1	R7	1.5	5.0	3.0	3.0		
BS016010BE920##BF1		2.0					
BS016010BE930##BF1		3.0					
BS016010BE940##BF1		4.0					
BS016010BE950##BG1	R16	5.0					
BS016010BE960##BG1		6.0					
BS016010BE970##BH1	R42	7.0				4.0	4.0
BS016010BE980##BH1		8.0					
BS016010BE100##BH1		10					
BS016010BE120##BH1		12					
BS016010BE160##BH1		16					
BS016010BE200##BJ1	R85	20		4.0	5.0		
BS016010BE250##BJ1		25					
BS016010BE300##BJ1		30					
BS016010BE400##BJ1		40					
BS016010BE500##BJ1		50					

SAP PART NUMBER AND ELECTRICAL DATA							
PART NUMBER	CERAMIC	CAP. VALUES (pF)	RATED VOLTAGE (kV _P)	RATED POWER ⁽¹⁾ (kvar)	RATED CURRENT (A _{RMS})		
TYPE TOS 025016							
BS025016WC920##BF1	R7	2.0	9.0	5.0	5.0		
BS025016WC930##BF1		3.0					
BS025016WC940##BF1		4.0					
BS025016WC950##BF1		5.0					
BS025016WC960##BF1		6.0					
BS025016WC970##BF1		7.0					
BS025016WC980##BG1	R16	8.0		8.0	6.0		
BS025016WC100##BG1		10					
BS025016WC120##BH1	R42	12					
BS025016WC160##BH1		16					
BS025016WC200##BH1		20					
BS025016WC250##BH1		25					
BS025016WC300##BJ1		R85				30	10
BS025016WC400##BJ1	40						
BS025016WC500##BJ1	50						
BS025016WC600##BJ1	60						
BS025016WC700##BJ1	70						
BS025016WC800##BJ1	80						
BS025016WC101##BJ1	100						

Notes

- # 14th to 15th digit: Capacitance tolerance code < 10 pF: ± 2 pF = 15; ± 1 pF = 14; ± 0.5 pF = 13
 ≥ 10 pF: ± 20 % = 38; ± 10 % = 36; ± 5 % = 33

⁽¹⁾ The surface temperature during operation must not exceed + 100 °C



SAP PART NUMBER AND ELECTRICAL DATA							
PART NUMBER	CERAMIC	CAP. VALUES (pF)	RATED VOLTAGE (kV _P)	RATED POWER ⁽¹⁾ (kvar)	RATED CURRENT (A _{RMS})		
TYPE TOF 016010							
BF016010BE915##BF1	R7	1.5	5.0	3.0	3.0		
BF016010BE920##BF1		2.0					
BF016010BE930##BF1		3.0					
BF016010BE940##BF1		4.0					
BF016010BE950##BG1	R16	5.0		4.0	4.0		
BF016010BE960##BG1		6.0					
BF016010BE970##BH1	R42	7.0				4.0	4.0
BF016010BE980##BH1		8.0					
BF016010BE100##BH1		10					
BF016010BE120##BH1		12					
BF016010BE160##BH1		16					
BF016010BE200##BJ1		R85					
BF016010BE250##BJ1	25						
BF016010BE300##BJ1	30						
BF016010BE400##BJ1	40						
BF016010BE500##BJ1	50						

SAP PART NUMBER AND ELECTRICAL DATA							
PART NUMBER	CERAMIC	CAP. VALUES (pF)	RATED VOLTAGE (kV _P)	RATED POWER ⁽¹⁾ (kvar)	RATED CURRENT (A _{RMS})		
TYPE TOF 025016							
BF025016WC920##BF1	R7	2.0	9.0	5.0	5.0		
BF025016WC930##BF1		3.0					
BF025016WC940##BF1		4.0					
BF025016WC950##BF1		5.0					
BF025016WC960##BF1		6.0					
BF025016WC970##BF1		7.0					
BF025016WC980##BG1	R16	8.0		8.0	6.0		
BF025016WC100##BG1		10					
BF025016WC120##BH1		12					
BF025016WC160##BH1	R42	16				8.0	6.0
BF025016WC200##BH1		20					
BF025016WC250##BH1		25					
BF025016WC300##BJ1		30					
BF025016WC400##BJ1	R85	40				10	10
BF025016WC500##BJ1		50					
BF025016WC600##BJ1		60					
BF025016WC700##BJ1		70					
BF025016WC800##BJ1		80					
BF025016WC101##BJ1		100					

Notes

- # 14th to 15th digit: Capacitance tolerance code < 10 pF: ± 2 pF = 15; ± 1 pF = 14; ± 0.5 pF = 13
 ≥ 10 pF: ± 20 % = 38; ± 10 % = 36; ± 5 % = 33
- (1) The surface temperature during operation must not exceed + 100 °C



DIMENSIONS in millimeters (inches)

TOF

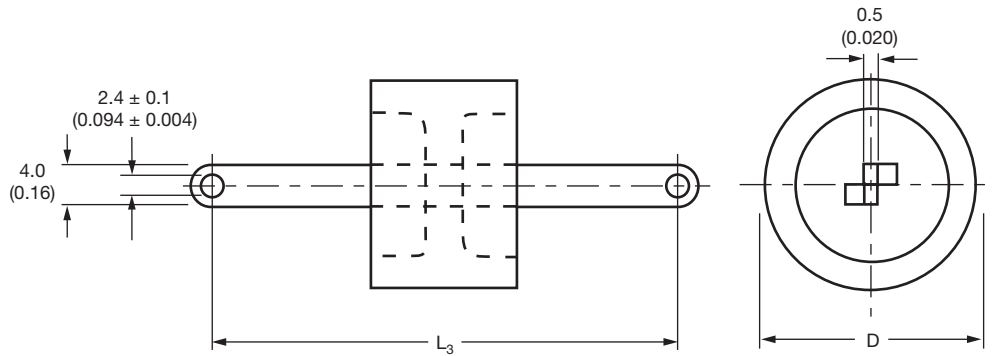

TOS

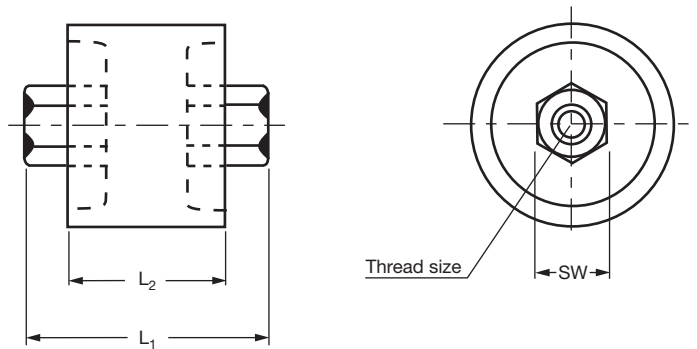

TYPE	TOF 016010	TOS 016010	TOF 025016	TOS 025016
Diameter $D_{max.}$	16 (0.63)	16 (0.63)	25 (0.98)	25 (0.98)
Thread size	-	M5 4.5 (0.178) depth	-	M6 7.0 (0.28 depth)
Length L_1 max. ⁽¹⁾	-	23 (0.91)	-	35 (1.38)
Length L_2 max. ⁽¹⁾	10 (0.39)	10 (0.39)	16 (0.63)	16 (0.63)
Length L_3 max. ⁽¹⁾	49 max. (1.93 max.)	-	55 max. (2.17 max.)	-
SW	-	8.0 (0.32) HEX	-	10 (0.39) HEX
Allowable torque ⁽²⁾	-	3.5 Nm (31 lbf in)	-	5.0 Nm (44 lbf in)

Notes

- ⁽¹⁾ Dimension L_1 , L_2 and L_3 will vary depending upon capacitance value
- ⁽²⁾ Use wrenches when tightening the screws and nuts on both ends of the capacitor



Disclaimer

ALL PRODUCT, PRODUCT SPECIFICATIONS AND DATA ARE SUBJECT TO CHANGE WITHOUT NOTICE TO IMPROVE RELIABILITY, FUNCTION OR DESIGN OR OTHERWISE.

Vishay Intertechnology, Inc., its affiliates, agents, and employees, and all persons acting on its or their behalf (collectively, "Vishay"), disclaim any and all liability for any errors, inaccuracies or incompleteness contained in any datasheet or in any other disclosure relating to any product.

Vishay makes no warranty, representation or guarantee regarding the suitability of the products for any particular purpose or the continuing production of any product. To the maximum extent permitted by applicable law, Vishay disclaims (i) any and all liability arising out of the application or use of any product, (ii) any and all liability, including without limitation special, consequential or incidental damages, and (iii) any and all implied warranties, including warranties of fitness for particular purpose, non-infringement and merchantability.

Statements regarding the suitability of products for certain types of applications are based on Vishay's knowledge of typical requirements that are often placed on Vishay products in generic applications. Such statements are not binding statements about the suitability of products for a particular application. It is the customer's responsibility to validate that a particular product with the properties described in the product specification is suitable for use in a particular application. Parameters provided in datasheets and/or specifications may vary in different applications and performance may vary over time. All operating parameters, including typical parameters, must be validated for each customer application by the customer's technical experts. Product specifications do not expand or otherwise modify Vishay's terms and conditions of purchase, including but not limited to the warranty expressed therein.

Except as expressly indicated in writing, Vishay products are not designed for use in medical, life-saving, or life-sustaining applications or for any other application in which the failure of the Vishay product could result in personal injury or death. Customers using or selling Vishay products not expressly indicated for use in such applications do so at their own risk. Please contact authorized Vishay personnel to obtain written terms and conditions regarding products designed for such applications.

No license, express or implied, by estoppel or otherwise, to any intellectual property rights is granted by this document or by any conduct of Vishay. Product names and markings noted herein may be trademarks of their respective owners.

Material Category Policy

Vishay Intertechnology, Inc. hereby certifies that all its products that are identified as RoHS-Compliant fulfill the definitions and restrictions defined under Directive 2011/65/EU of The European Parliament and of the Council of June 8, 2011 on the restriction of the use of certain hazardous substances in electrical and electronic equipment (EEE) - recast, unless otherwise specified as non-compliant.

Please note that some Vishay documentation may still make reference to RoHS Directive 2002/95/EC. We confirm that all the products identified as being compliant to Directive 2002/95/EC conform to Directive 2011/65/EU.

Vishay Intertechnology, Inc. hereby certifies that all its products that are identified as Halogen-Free follow Halogen-Free requirements as per JEDEC JS709A standards. Please note that some Vishay documentation may still make reference to the IEC 61249-2-21 definition. We confirm that all the products identified as being compliant to IEC 61249-2-21 conform to JEDEC JS709A standards.