

Features

- Diffused Junction
- Low Forward Voltage Drop
- High Current Capability
- High Reliability
- High Surge Current Capability
- Ideal for Printed Circuit Boards
- UL Recognized File # E157705

Mechanical Data

- Case: Molded Plastic
- Terminals: Plated Leads Solderable per MIL-STD-202, Method 208
- Polarity: As Marked on Body
- Weight: 8.0 grams (approx.)
- Mounting Position: Any
- Marking: Type Number

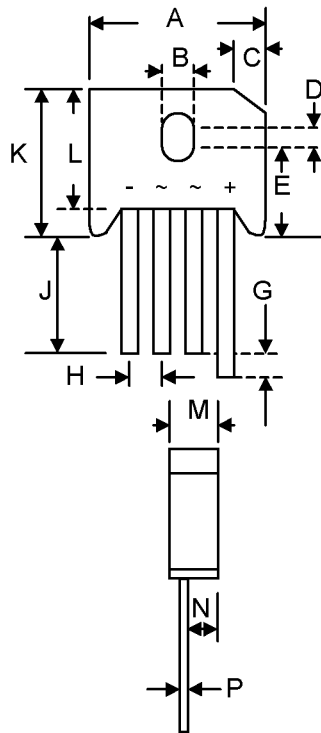

KBU		
Dim	Min	Max
A	22.70	23.70
B	3.80	4.10
C	4.20	4.70
D	1.70	2.20
E	10.30	11.30
G	4.50	6.80
H	4.60	5.60
J	25.40	—
K	—	19.30
L	16.80	17.80
M	6.60	7.10
N	4.70	5.20
P	1.20	1.30
All Dimensions in mm		

Maximum Ratings and Electrical Characteristics @ $T_A=25^\circ\text{C}$ unless otherwise specified

Single Phase, half wave, 60Hz, resistive or inductive load.
For capacitive load, derate current by 20%.

Characteristic	Symbol	KBU 800	KBU 801	KBU 802	KBU 804	KBU 806	KBU 808	KBU 810	Unit
Peak Repetitive Reverse Voltage Working Peak Reverse Voltage DC Blocking Voltage	V_{RRM} V_{RWM} V_R	50	100	200	400	600	800	1000	V
RMS Reverse Voltage	$V_{R(RMS)}$	35	70	140	280	420	560	700	V
Average Rectified Output Current @ $T_c = 100^\circ\text{C}$	I_o	8.0							A
Non-Repetitive Peak Forward Surge Current 8.3ms Single half sine-wave superimposed on rated load (JEDEC Method)	I_{FSM}	300							A
Forward Voltage (per element) @ $I_f = 4.0\text{A}$	V_{FM}	1.0							V
Peak Reverse Current @ $T_c = 25^\circ\text{C}$ At Rated DC Blocking Voltage @ $T_c = 100^\circ\text{C}$	I_R	10 1.0							μA mA
Rating for Fusing ($t < 8.3\text{ms}$) (Note 1)	I^2t	373							A^2s
Typical Thermal Resistance (Note 2)	$R_{\theta JC}$	7.5							K/W
Operating and Storage Temperature Range	T_j, T_{STG}	-65 to +150							$^\circ\text{C}$

Note: 1. Non-repetitive for $t > 1\text{ms}$ and $< 8.3\text{ms}$.
2. Thermal resistance junction to case per element mounted on PC board with 13.0x13.0x0.03mm thick land areas.

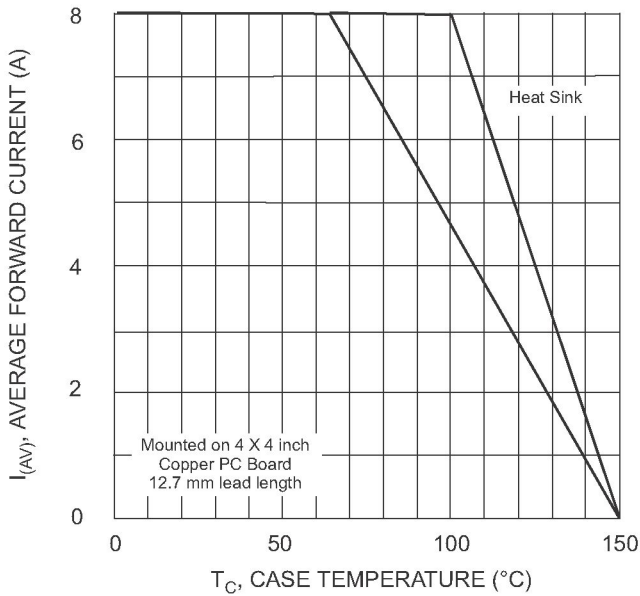

Fig. 1 Forward Current Derating Curve

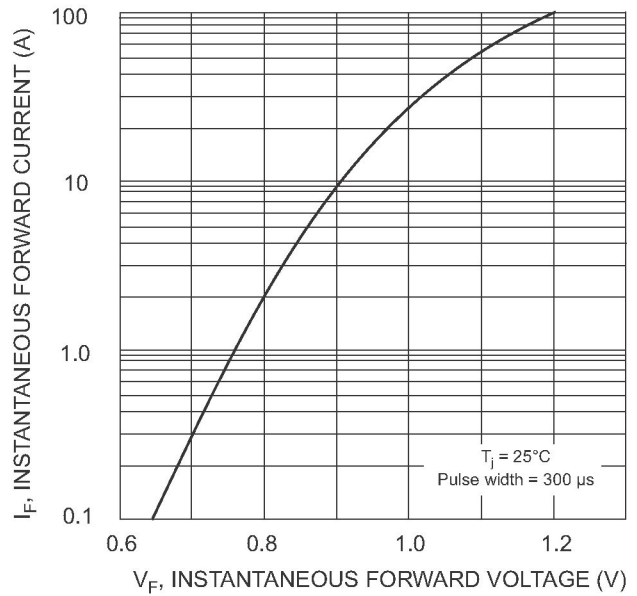

Fig. 2 Typical Forward Characteristics, per element

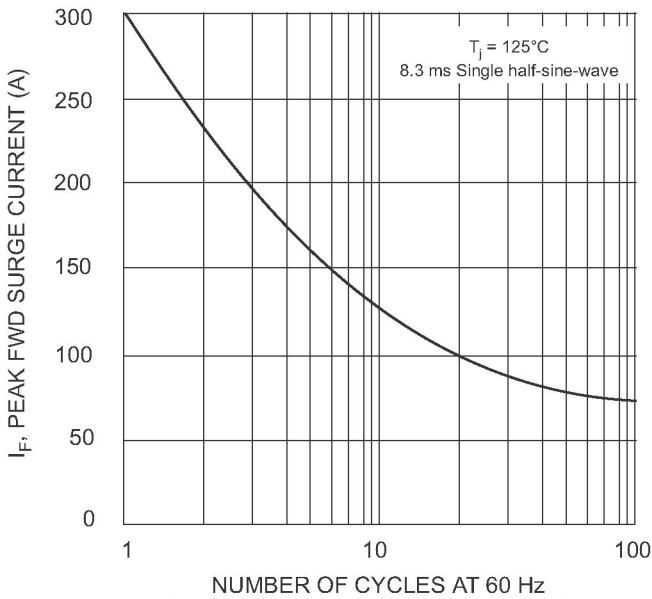

Fig. 3 Max Non-Repetitive Forward Surge Current

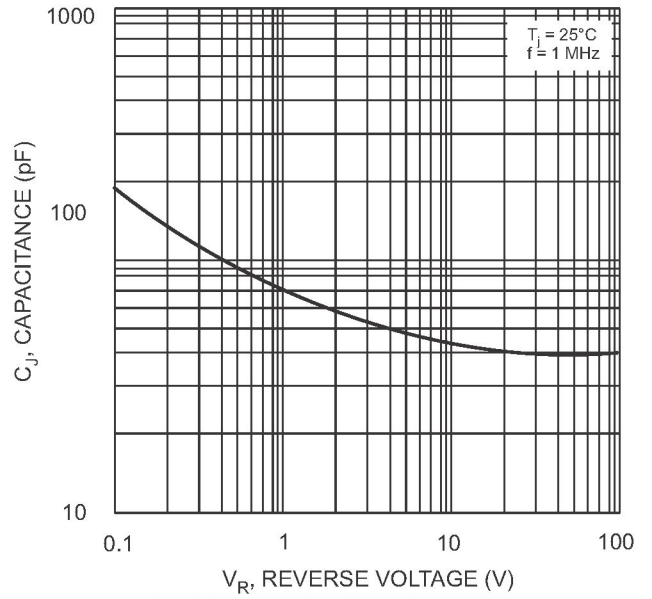

Fig. 4 Typ Junction Capacitance per element

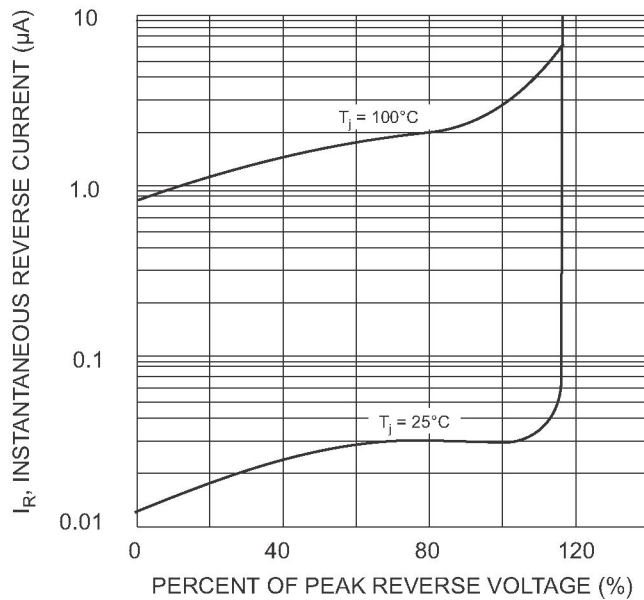

Fig. 5 Typical Reverse Characteristics

ORDERING INFORMATION

Product No.	Package Type	Shipping Quantity
KBU800	SIL Bridge	400 Units/Box
KBU801	SIL Bridge	400 Units/Box
KBU802	SIL Bridge	400 Units/Box
KBU804	SIL Bridge	400 Units/Box
KBU806	SIL Bridge	400 Units/Box
KBU808	SIL Bridge	400 Units/Box
KBU810	SIL Bridge	400 Units/Box

Shipping quantity given is for minimum packing quantity only. For minimum order quantity, please consult the Sales Department.

Won-Top Electronics Co., Ltd (WTE) has checked all information carefully and believes it to be correct and accurate. However, WTE cannot assume any responsibility for inaccuracies. Furthermore, this information does not give the purchaser of semiconductor devices any license under patent rights to manufacturer. WTE reserves the right to change any or all information herein without further notice.

WARNING: DO NOT USE IN LIFE SUPPORT EQUIPMENT. WTE power semiconductor products are not authorized for use as critical components in life support devices or systems without the express written approval.

Won-Top Electronics Co., Ltd.

No. 44 Yu Kang North 3rd Road, Chine Chen Dist., Kaohsiung, Taiwan

Phone: 886-7-822-5408 or 886-7-822-5410

Fax: 886-7-822-5417

Email: sales@wontop.com

Internet: <http://www.wontop.com>

We power your everyday.