

**SINGLE-PHASE GLASS PASSIVATED
SILICON BRIDGE RECTIFIER**

VOLTAGE RANGE 50 to 1000 Volts CURRENT 4.0 Ampere

FEATURES

- * Ideal for printed circuit board
- * Surge overload rating: 200 amperes peak
- * Mounting position: Any
- * Weight: 4.8 grams
- * Molded structure

MECHANICAL DATA

- * UL listed the recognized component directory, file #E94233
- * Epoxy: Device has UL flammability classification 94V-O



RS-4L

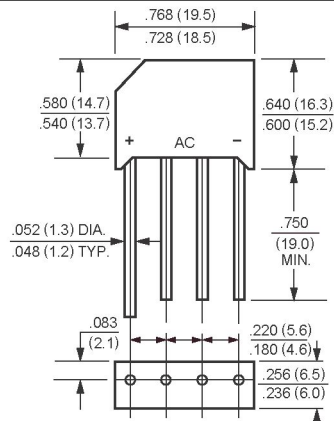

Dimensions in inches and (millimeters)

MAXIMUM RATINGS AND ELECTRICAL CHARACTERISTICS

Ratings at 25°C ambient temperature unless otherwise specified.
Single phase, half wave, 60 Hz, resistive or inductive load.
For capacitive load, derate current by 20%.

MAXIMUM RATINGS (At TA = 25°C unless otherwise noted)

RATINGS	SYMBOL	RS401L	RS402L	RS403L	RS404L	RS405L	RS406L	RS407L	UNITS
Maximum Recurrent Peak Reverse Voltage	VRRM	50	100	200	400	600	800	1000	Volts
Maximum RMS Bridge Input Voltage	VRMS	35	70	140	280	420	560	700	Volts
Maximum DC Blocking Voltage	VDC	50	100	200	400	600	800	1000	Volts
Maximum Average Forward Output Current TA = 75°C	IO	4.0							Amps
Peak Forward Surge Current 8.3 ms single half sine-wave superimposed on rated load (JEDEC method)	IFSM	200							Amps
Operating Temperature Range	TJ	-55 to + 150							°C
Storage Temperature Range	TSTG	-55 to + 150							°C
Typical Junction Capacitance (Note)	CJ	40							pF

ELECTRICAL CHARACTERISTICS (At TA = 25°C unless otherwise noted)

CHARACTERISTICS	SYMBOL	RS401L	RS402L	RS403L	RS404L	RS405L	RS406L	RS407L	UNITS
Maximum Forward Voltage Drop per Bridge Element at 4.0A DC	VF	1.0							Volts
Maximum Reverse Current at Rated Dc Blocking Voltage per element	IR	10							uAmps
									@TA = 100°C

NOTES : Measured at 1 MHz and applied reverse voltage of 4.0 volts

2001-5

RATING AND CHARACTERISTIC CURVES (RS401L THRU RS407L)

