

To all our customers

**Information regarding change of names mentioned
within this document, to Renesas Technology Corp.**

On April 1st 2003 the following semiconductor operations were transferred to Renesas Technology Corporation: operations covering microcomputer, logic, analog and discrete devices, and memory chips other than DRAMs (flash memory, SRAMs etc.).

Accordingly, although Hitachi, Hitachi, Ltd., Hitachi Semiconductors, and other Hitachi brand names are mentioned in the document, these names have all been changed to Renesas Technology Corporation.

Except for our corporate trademark, logo and corporate statement, no changes whatsoever have been made to the contents of the document, and these changes do not constitute any alteration to the contents of the document itself.

Thank you for your understanding.

Renesas Technology Home Page: www.renesas.com

Renesas Technology Corp.
April 1, 2003

HD66420

(RAM-Provided 160 Channel 4-Level Grey Scale Driver for Dot Matrix Graphics LCD)

HITACHI

ADE-207-299(Z)
Rev. 4.0
'99.12

Description

The HD66420 drives and controls a dot matrix graphic LCD(Liquid Crystal Display) using a bit-mapped method. It provides a highly flexible display through its on-chip display RAM, in which each two bits of data can be used to turn on or off one dot on LCD panel with four-level grey scale.

A single HD66420 can display a maximum of 160x80 dots using its powerful display control functions. It can display only eight lines out of eighty lines. This function realize low power consumption because high voltage for driving LCD is not needed.

An MPU can access HD66420 at any time, because the MPU operations are asynchronous with the HD66420's system clock and display operation.

Its low-voltage operation at 2.2 to 5.5V and standby function provides low power dissipation, making the HD66420 suitable for small portable device applications.

Features

- Built-in bit-mapped display RAM: 25.6kbits (160 × 80 × 2 bits)
- Grey scale display: PWM four-level grey scale can be selected from 32 levels
- Grey scale memory management: Packed pixel
- Partial display: Eight-lines data can be displayed in any place
- An 80-system MPU interface
- Power supply voltage for operation : 2.2V to 5.5V
- Power supply voltage for LCD : 15 V max.
- Selectable multiplex duty ratio: 1/8, 1/32, 1/64, 1/80
- Built-in oscillator: external resister
- Low power consumption:
 - 55μA typ. 80μA max. during display
 - 0.1μA typ. 5μA max. during standby
- Circuits for generating LCD driving voltage : Contrast control, Operational amplifier, and Resistive dividers
- Internal resistive divider: programmable bias rate
- 32-level programmable contrast control

HD66420

- Wide range of instructions reversible display, display on/off, vertical display scroll, blink, reversible address, read-modify-write mode
- Package: TCP

Ordering Information

Type No.	Package
HD66420TA0	TCP
HCD66420BP	Die with gold bump

Pin Arrangement

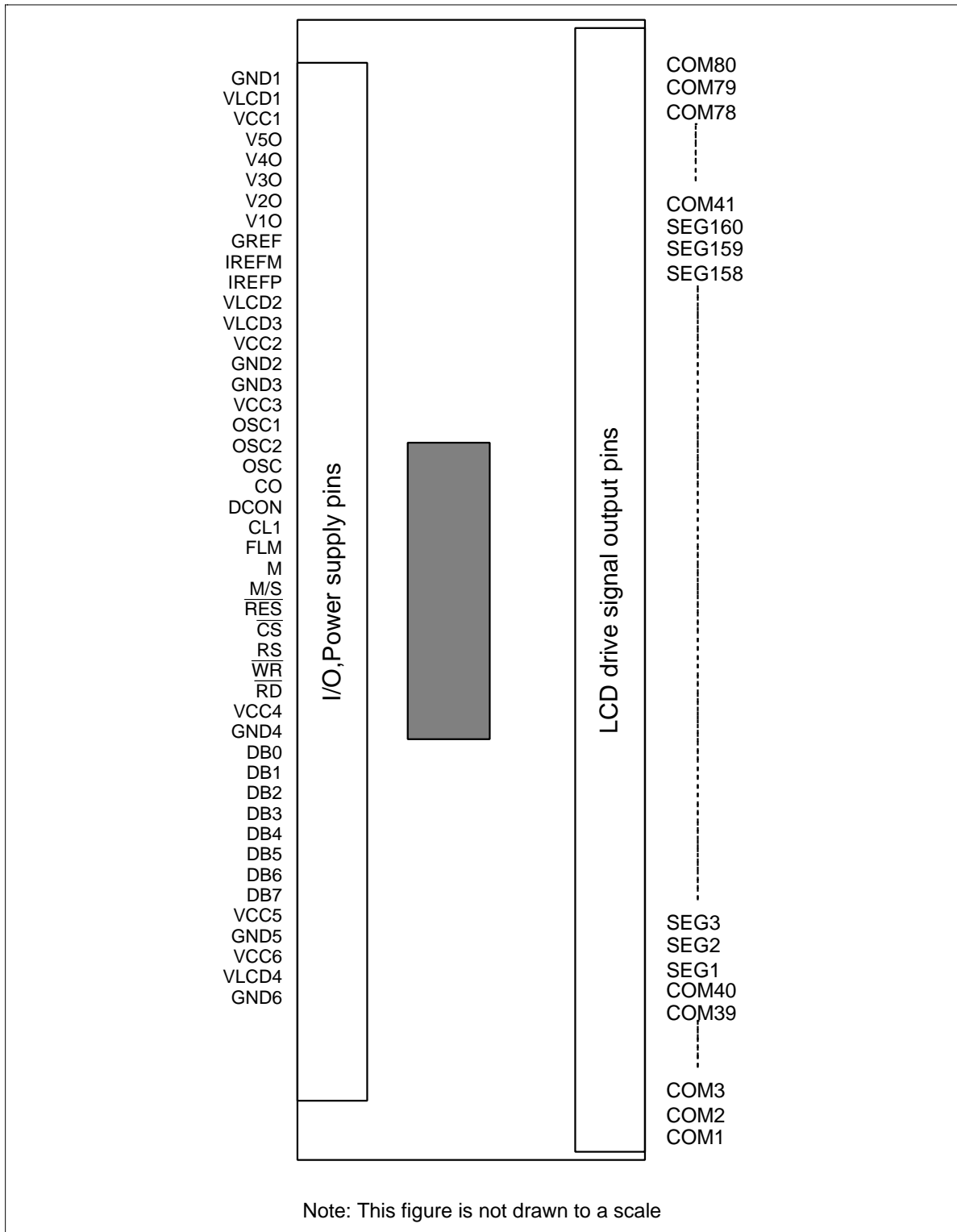

HD66420

Pad Arrangement

Chip Size : 8.99 × 4.22 mm
 Coordinate : Pad Center
 Origin : Chip center
 BUMP Size :
 No.1-64, 72-183, 191-254: 35 × 50 μm
 No.66-71, 184-189, 256-301: 50 × 70 μm
 No.65, 190, 255, 302: 70 × 70 μm

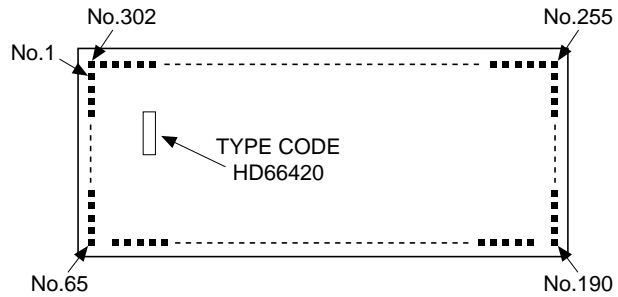

Pad Location Coordinate

Pin No.	Pad Name	Coordinate		Pin No.	Pad Name	Coordinate		Pin No.	Pad Name	Coordinate		Pin No.	Pad Name	Coordinate	
		X	Y			X	Y			X	Y			X	Y
1	COM1	-4217	1481	26	COM26	-4217	230	51	SEG11	-4217	-1049	76	SEG29	-2622	-1832
2	COM2	-4217	1430	27	COM27	-4217	179	52	SEG12	-4217	-1099	77	SEG30	-2572	-1832
3	COM3	-4217	1380	28	COM28	-4217	129	53	SEG13	-4217	-1149	78	SEG31	-2522	-1832
4	COM4	-4217	1330	29	COM29	-4217	79	54	SEG14	-4217	-1199	79	SEG32	-2472	-1832
5	COM5	-4217	1280	30	COM30	-4217	29	55	SEG15	-4217	-1249	80	SEG33	-2422	-1832
6	COM6	-4217	1230	31	COM31	-4217	-21	56	SEG16	-4217	-1299	81	SEG34	-2372	-1832
7	COM7	-4217	1180	32	COM32	-4217	-71	57	SEG17	-4217	-1349	82	SEG35	-2322	-1832
8	COM8	-4217	1130	33	COM33	-4217	-121	58	SEG18	-4217	-1399	83	SEG36	-2272	-1832
9	COM9	-4217	1080	34	COM34	-4217	-171	59	SEG19	-4217	-1449	84	SEG37	-2222	-1832
10	COM10	-4217	1030	35	COM35	-4217	-221	60	SEG20	-4217	-1499	85	SEG38	-2172	-1832
11	COM11	-4217	980	36	COM36	-4217	-271	61	SEG21	-4217	-1549	86	SEG39	-2121	-1832
12	COM12	-4217	930	37	COM37	-4217	-321	62	SEG22	-4217	-1599	87	SEG40	-2071	-1832
13	COM13	-4217	880	38	COM38	-4217	-371	63	SEG23	-4217	-1649	88	SEG41	-2021	-1832
14	COM14	-4217	830	39	COM39	-4217	-421	64	SEG24	-4217	-1699	89	SEG42	-1971	-1832
15	COM15	-4217	780	40	COM40	-4217	-471	65	dummyA	-4289	-1832	90	SEG43	-1921	-1832
16	COM16	-4217	730	41	SEG1	-4217	-548	66	dummy1	-4029	-1832	91	SEG44	-1871	-1832
17	COM17	-4217	680	42	SEG2	-4217	-598	67	dummy2	-3907	-1832	92	SEG45	-1821	-1832
18	COM18	-4217	630	43	SEG3	-4217	-648	68	dummy3	-3827	-1832	93	SEG46	-1771	-1832
19	COM19	-4217	580	44	SEG4	-4217	-698	69	dummy4	-3619	-1832	94	SEG47	-1721	-1832
20	COM20	-4217	530	45	SEG5	-4217	-748	70	dummy5	-3497	-1825	95	SEG48	-1671	-1832
21	COM21	-4217	480	46	SEG6	-4217	-798	71	dummy6	-3419	-1825	96	SEG49	-1621	-1832
22	COM22	-4217	430	47	SEG7	-4217	-848	72	SEG25	-2822	-1832	97	SEG50	-1571	-1832
23	COM23	-4217	380	48	SEG8	-4217	-898	73	SEG26	-2772	-1832	98	SEG51	-1521	-1832
24	COM24	-4217	330	49	SEG9	-4217	-948	74	SEG27	-2722	-1832	99	SEG52	-1471	-1832
25	COM25	-4217	280	50	SEG10	-4217	-998	75	SEG28	-2672	-1832	100	SEG53	-1421	-1832

HD66420

Pin No.	Pad Name	Coordinate		Pin No.	Pad Name	Coordinate		Pin No.	Pad Name	Coordinate		Pin No.	Pad Name	Coordinate	
		X	Y			X	Y			X	Y			X	Y
101	SEG54	-1371	-1832	126	SEG79	-120	-1832	151	SEG104	1221	-1832	176	SEG129	2472	-1832
102	SEG55	-1321	-1832	127	SEG80	-70	-1832	152	SEG105	1271	-1832	177	SEG130	2522	-1832
103	SEG56	-1271	-1832	128	SEG81	70	-1832	153	SEG106	1321	-1832	178	SEG131	2572	-1832
104	SEG57	-1221	-1832	129	SEG82	120	-1832	154	SEG107	1371	-1832	179	SEG132	2622	-1832
105	SEG58	-1171	-1832	130	SEG83	170	-1832	155	SEG108	1421	-1832	180	SEG133	2672	-1832
106	SEG59	-1121	-1832	131	SEG84	220	-1832	156	SEG109	1471	-1832	181	SEG134	2722	-1832
107	SEG60	-1071	-1832	132	SEG85	270	-1832	157	SEG110	1521	-1832	182	SEG135	2772	-1832
108	SEG61	-1021	-1832	133	SEG86	320	-1832	158	SEG111	1571	-1832	183	SEG136	2822	-1832
109	SEG62	-971	-1832	134	SEG87	370	-1832	159	SEG112	1621	-1832	184	dummy7	3419	-1825
110	SEG63	-921	-1832	135	SEG88	420	-1832	160	SEG113	1671	-1832	185	dummy8	3497	-1825
111	SEG64	-870	-1832	136	SEG89	470	-1832	161	SEG114	1721	-1832	186	dummy9	3619	-1832
112	SEG65	-820	-1832	137	SEG90	520	-1832	162	SEG115	1771	-1832	187	dummy10	3827	-1832
113	SEG66	-770	-1832	138	SEG91	570	-1832	163	SEG116	1821	-1832	188	dummy11	3907	-1832
114	SEG67	-720	-1832	139	SEG92	620	-1832	164	SEG117	1871	-1832	189	dummy12	4029	-1832
115	SEG68	-670	-1832	140	SEG93	670	-1832	165	SEG118	1921	-1832	190	dummyB	4289	-1832
116	SEG69	-620	-1832	141	SEG94	720	-1832	166	SEG119	1971	-1832	191	SEG137	4217	-1699
117	SEG70	-570	-1832	142	SEG95	770	-1832	167	SEG120	2021	-1832	192	SEG138	4217	-1649
118	SEG71	-520	-1832	143	SEG96	820	-1832	168	SEG121	2071	-1832	193	SEG139	4217	-1599
119	SEG72	-470	-1832	144	SEG97	870	-1832	169	SEG122	2121	-1832	194	SEG140	4217	-1549
120	SEG73	-420	-1832	145	SEG98	921	-1832	170	SEG123	2172	-1832	195	SEG141	4217	-1499
121	SEG74	-370	-1832	146	SEG99	971	-1832	171	SEG124	2222	-1832	196	SEG142	4217	-1449
122	SEG75	-320	-1832	147	SEG100	1021	-1832	172	SEG125	2272	-1832	197	SEG143	4217	-1399
123	SEG76	-270	-1832	148	SEG101	1071	-1832	173	SEG126	2322	-1832	198	SEG144	4217	-1349
124	SEG77	-220	-1832	149	SEG102	1121	-1832	174	SEG127	2372	-1832	199	SEG145	4217	-1299
125	SEG78	-170	-1832	150	SEG103	1171	-1832	175	SEG128	2422	-1832	200	SEG146	4217	-1249

HD66420

Pin No.	Pad Name	Coordinate		Pin No.	Pad Name	Coordinate		Pin No.	Pad Name	Coordinate		Pin No.	Pad Name	Coordinate	
		X	Y			X	Y			X	Y			X	Y
201	SEG147	4217	-1199	238	COM64	4217	680	266	IREFP	2360	1945	285	WR	-1226	1945
202	SEG148	4217	-1149	239	COM65	4217	730			2280	1945			-1306	1945
203	SEG149	4217	-1099	240	COM66	4217	780	267	VLCD2	2179	1945	286	RD	-1407	1945
204	SEG150	4217	-1049	241	COM67	4217	830			2099	1945			-1487	1945
205	SEG151	4217	-998	242	COM68	4217	880	268	VLCD3	2009	1945	287	VCC4	-1587	1945
206	SEG152	4217	-948	243	COM69	4217	930			1929	1945			-1667	1945
207	SEG153	4217	-898	244	COM70	4217	980	269	VCC2	1830	1945	298	GND4	-1770	1945
208	SEG154	4217	-848	245	COM71	4217	1030			1750	1945			-1850	1945
209	SEG155	4217	-798	246	COM72	4217	1080	270	GND2	1647	1945	289	DB0	-1948	1945
210	SEG156	4217	-748	247	COM73	4217	1130			1567	1945			-2028	1945
211	SEG157	4217	-698	248	COM74	4217	1180	271	GND3	1494	1945	290	DB1	-2131	1945
212	SEG158	4217	-648	249	COM75	4217	1230			1414	1945			-2211	1945
213	SEG159	4217	-598	250	COM76	4217	1280	272	VCC3	1316	1945	291	DB2	-2310	1945
214	SEG160	4217	-548	251	COM77	4217	1330			1236	1945			-2390	1945
215	COM41	4217	-471	252	COM78	4217	1380	273	OSC1	947	1945	292	DB3	-2494	1945
216	COM42	4217	-421	253	COM79	4217	1430			867	1945			-2574	1945
217	COM43	4217	-371	254	COM80	4217	1481	274	OSC2	766	1945	293	DB4	-2672	1945
218	COM44	4217	-321	255	dummyC	4289	1945			686	1945			-2752	1945
219	COM45	4217	-271	256	GND1	4171	1945	275	OSC	585	1945	294	DB5	-2856	1945
220	COM46	4217	-221			4091	1945			505	1945			-2936	1945
221	COM47	4217	-171	257	VLCD1	3992	1945	276	CO	404	1945	295	DB6	-3034	1945
222	COM48	4217	-121			3912	1945			324	1945			-3114	1945
223	COM49	4217	-71	258	VCC1	3809	1945	277	DCON	223	1945	296	DB7	-3218	1945
224	COM50	4217	-21			3729	1945			143	1945			-3298	1945
225	COM51	4217	29	259	V5O	3628	1945	278	CL1	41	1945	297	VCC5	-3398	1945
226	COM52	4217	79			3548	1945			-39	1945			-3478	1945
227	COM53	4217	129	260	V4O	3447	1945	279	FLM	-140	1945	298	GND5	-3581	1945
228	COM54	4217	179			3367	1945			-220	1945			-3661	1945
229	COM55	4217	230	261	V3O	3266	1945	280	M	-321	1945	299	VCC6	-3739	1945
230	COM56	4217	280			3186	1945			-401	1945			-3819	1945
231	COM57	4217	330	262	V2O	3084	1945	281	M/S	-502	1945	300	VLCD4	-3910	1945
232	COM58	4217	380			3004	1945			-582	1945			-3990	1945
233	COM59	4217	430	263	V1O	2903	1945	282	RES	-683	1945	301	GND6	-4091	1945
234	COM60	4217	480			2823	1945			-763	1945			-4171	1945
235	COM61	4217	530	264	REF	2722	1945	283	CS	-864	1945	302	dummyD	-4289	1945
236	COM62	4217	580			2642	1945			-944	1945				
237	COM63	4217	630	265	IREFM	2541	1945	284	RS	-1045	1945				
						2461	1945			-1125	1945				

Pin Description

Pin Name	Number of Pins	I/O	Connected to	Description
V _{cc} 1–6, GND1–6	12	—	Power supply	V _{cc} : +2.2V to +5.5V, GND: 0V
VLCD1–4	4	—	Power supply	Power supply to LCD driving circuit
V10, V20, V30, V40, V50	5	—	Capacitors or external power supply	Several levels of power to the LCD driving outputs. Master HD66420 outputs these levels to the slave HD66420.
OSC	1	I	Oscillator resistor or external clock	Must be connected to external resistor when using R-C oscillation. When using an external clock, it must be input to the OSC terminal.
OSC1, OSC2	2	I/O		
CO	1	O	OSC of Slave HD66420	Clock output. The master LSI outputs clock to slave LSI.
DCON	1	O	External DC/DC convertor	Controls on/off switch of external DC/DC convertor
CL1	1	I/O	CL1 of HD66420 or open	Line clock. The master LSI outputs clock to slave LSI.
FLM	1	I/O	FLM of HD66420 or open	Frame signal. The master LSI outputs this signal to slave LSI.
M	1	I/O	M of HD66420 or open	Converts LCD driving outputs to AC. The master LSI outputs this signal to slave LSI.
M/S	1	I	V _{cc} or GND	Specifies master/slave mode. It works as master-chip when drive high, and slave-chip when drive low.
$\overline{\text{RES}}$	1	I	—	Reset the LSI internally when drive low.
$\overline{\text{CS}}$	1	I	MPU	Select the LSI, specifically internal registers (index and data registers) when driven low.
RS	1	I	MPU	Select one of the internal registers; select the index register when driven low and data registers when driven low.
$\overline{\text{WR}}$	1	I	MPU	Inputs write strobe; allows a write access when driven low.
$\overline{\text{RD}}$	1	I	MPU	Inputs read strobe; allows a read access when driven low.
DB7 to DB0	8	I/O	MPU	8-bits three-state bidirectional data bus; transfer data between the HD66420 and MPU through this bus.
SEG1 to SEG160	160	O	LCD	Output segment drive signals
COM1 to COM80	80	O	LCD	Output common drive signals

HD66420

Pin Description (cont)

Pin Name	Number of Pins	I/O	Connected to	Description
IREFP	1	—	V _{CC}	Power supply for internal operation amplifier
IREFM	1	—	External resistor	Bias current for internal operational amplifier
GREF	1	—	GND	Power supply for internal operation amplifier

Block Diagram

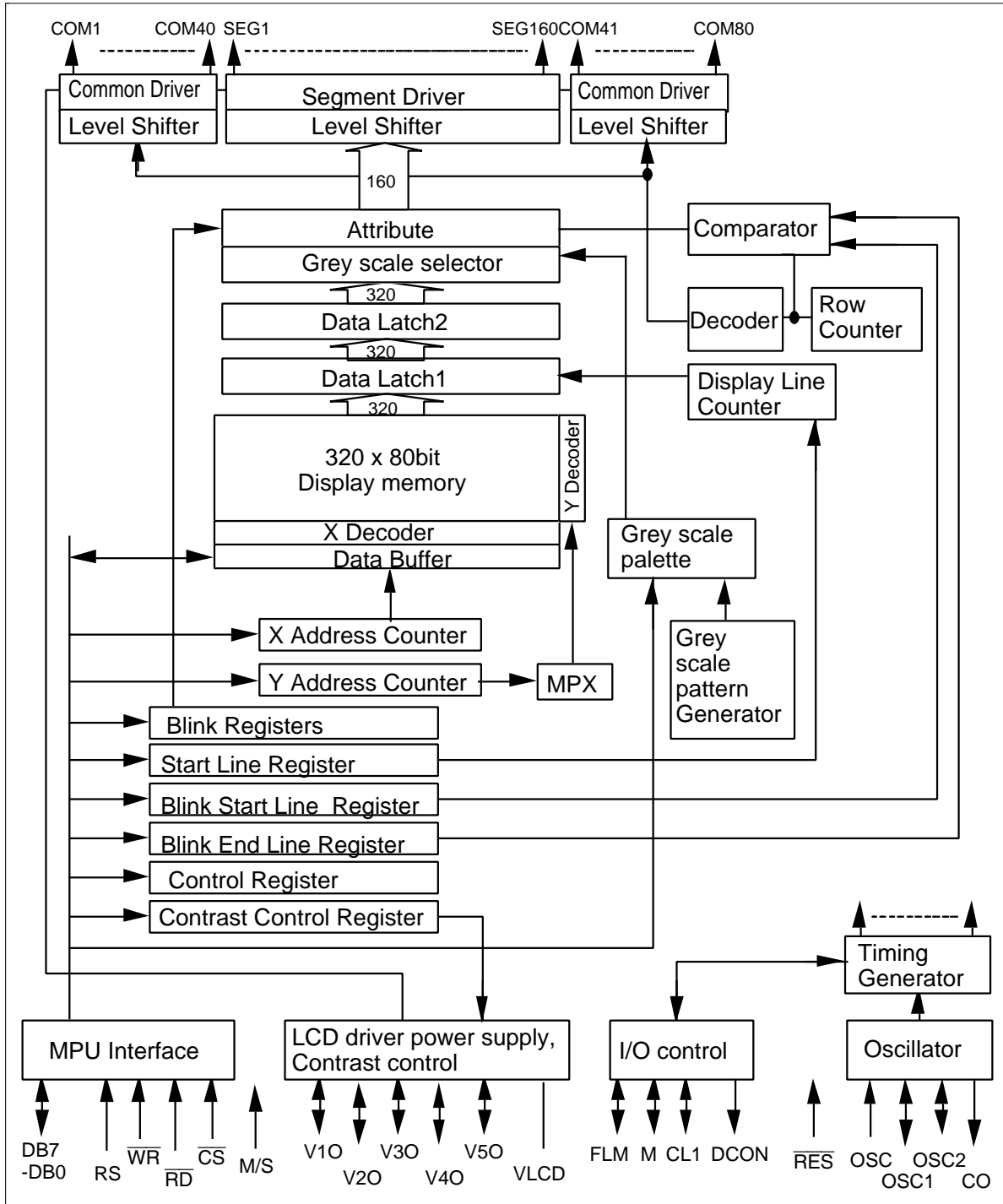

HD66420

System Description

The HD66420 can display a maximum of 160×80 dots (ten 16x16-dot characters \times 5 lines) four-level gray scale or four colour LCD panel. Four levels of gray scale can be selected from 32-levels, so the appropriate 4-level gray scale can be displayed.

The HD66420 can reduce power dissipation without affecting display because data is retained in the display RAM even during standby modes. An LCD system can be configured simply by attaching external power supply, capacitors and resistors (figure 1) since the HD66420 incorporates power circuits.

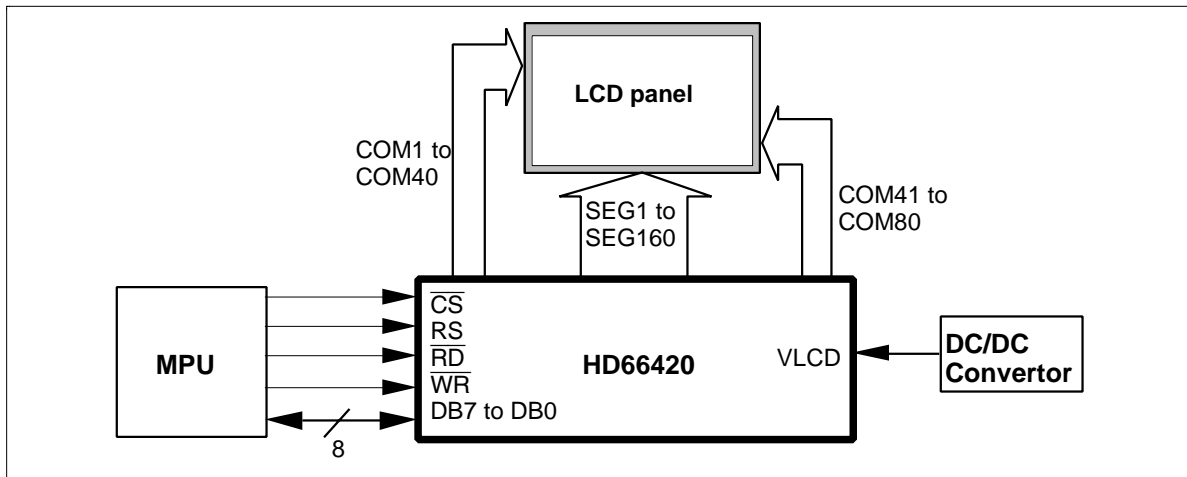

Figure 1 System Block Diagram

Internal Registers

The HD66420 has one index register and 17 data registers, all of which can be accessed asynchronously with the internal clock. All the registers except the display memory access register are write-only. Accessing unused bits or addresses affects nothing; unused bits should be set to 0 when written to.

Index Register (IR): The index register (figure 2) selects one of 17 data registers. The index register itself is selected when both the \overline{CS} and \overline{RS} signals are low. Data bits 7 to 5 are unused; they should be set to 0 when written to.

Control Register 1 (R0): Control register 1 (figure 3) controls general operations of the HD66420. Each bit has its own function as described below.

RMW bit

RMW = 1: Read-modify-write mode. Address is incremented only after write access

RMW = 0: Address is incremented after both write and read accesses

DISP bit

DISP = 1: Display on

DISP = 0: Display off (all LCD driver output pins output VLCD level)

STBY bit

STBY = 1: Internal operation and oscillation halt; display off

STBY = 0: Normal operation

PWR bit

PWR = 1: Output high level from DCON terminal

PWR = 0: Output low level from DCON terminal

This bit controls the external power supply for LCD driving outputs.

AMP bit

AMP = 1: OP amp enable

AMP = 0: OP amp disable

REV bit

REV = 1: Reverse display

REV = 0: Normal display

HOLT bit

HOLT = 1 : Internal operation stops

HOLT = 0: Internal operation starts

ADC bit

ADC = 1: Data in X address H'0 is output from SEG160

ADC = 0: Data in X address H'0 is output from SEG1

Data bit	7	6	5	4	3	2	1	0
Set value	0	0	0	Register number				

Figure 2 Index Register (IR)

Data bit	7	6	5	4	3	2	1	0
Set value	RMW	DISP	STBY	PWR	AMP	REV	HOLT	ADC

Figure 3 Control Register 1 (R0)

Control Register 2 (R1): Control register 2 (figure 4) controls general operations of the HD66420. Each bit has its own function as described below.

BIS1, BIS0 bits

BIS1, 0 = (1, 1): 1/6 LCD drive levels bias ratio

BIS1, 0 = (1, 0): 1/7 LCD drive levels bias ratio

BIS1, 0 = (0, 1): 1/8 LCD drive levels bias ratio

BIS1, 0 = (0, 0): 1/9 LCD drive levels bias ratio

HD66420

WLS bit

WLS = 1: A word length is 6-bits

WLS = 0: A word length is 8-bits

GRAY bit

GRAY = 1 : 4-levels of gray scale are fixed

GRAY = 0: 4-levels of gray scale are selected from 32-levels

DTY1,DTY0 bits

DTY1, 0 = (1, 1): 1/8 display duty cycle; partial display mode

DTY1, 0 = (1, 0): 1/32 display duty cycle

DTY1, 0 = (0, 1): 1/64 display duty cycle

DTY1, 0 = (0, 0): 1/80 display duty cycle

INC bit

INC = 1: X address is incremented for each access

INC = 0: Y address is incremented for each access

BLK bit

BLK = 1: Blink function is used

BLK = 0: Blink function is not used

The blink counter is reset when the BLK bit is set to 0. It starts counting and at the same time initiates blinking when the BLK bit is set to 1.

X Address Register (R2): The X address register (figure 5) designates the X address of the display RAM to be accessed by the MPU. The set value must range from H'00 to H'27 in the case of 8-bit a word or range from H'00 to H'35 in the case of 6-bit a word; setting a greater value is ignored. The set address is automatically incremented each time the display RAM is accessed; it is not necessary to update the address each time. Data bits 7 and 6 are unused; they should be set to 0 when written to.

Y Address Register (R3): The Y address register (figure 6) designates the Y address of the display RAM to be accessed by the MPU. The set value must range from H'00 to H'40; setting a greater value is ignored. The set address is automatically incremented each time the display RAM is accessed; it is not necessary to update the address each time. Data bit 7 is unused; it should be set to 0 when written to.

Data bit	7	6	5	4	3	2	1	0
Set value	BIS1	BIS0	WLS	GRAY	DTY1	DTY0	INC	BLK

Figure 4 Control Register 2 (R1)

Data bit	7	6	5	4	3	2	1	0
Set value	0	0	XA5	XA4	XA3	XA2	XA1	XA0

Figure 5 X address Register (R2)

Data bit	7	6	5	4	3	2	1	0
Set value	0	YA6	YA5	YA4	YA3	YA2	YA1	YA0

Figure 6 Y address Register (R3)

Display Memory Access Register (R4): The display memory access register (figure 7) is used to access the display RAM. If this register is write-accessed, data is directly written to the display RAM. If this register is read-accessed, data is first latched to this register from the display RAM and sent out to the data bus on the next read; therefore, a dummy read access is necessary after setting the display RAM address.

Display Start Raster Register (R5): The display start raster register (figure 8) designates the raster to be displayed at the top of the LCD panel. Varying the set value scrolls the display vertically.

The set value must be one less than the actual top raster and less than the duty ratio. If the value is set outside these ranges, data may not be displayed correctly. Data bits 7 is unused; they should be set to 0 when written to.

Blink Start Raster Register (R6): The blink start raster register (figure 9) designates the top raster in the area to be blinked. The set value must be one less than the actual top raster and less than the duty ratio. If the value is set outside these ranges, operations may not be correct. Data bits 7 is unused; they should be set to 0 when written to.

Blink End Raster Register (R7): The blink end register (figure 10) designates the bottom raster in the area to be blinked. The area to be blinked is designated by the blink registers, blink start raster register, and blink end raster register. The set value must be one less than the actual bottom raster and less than the duty ratio.

It must also be greater than the value set in the blink start raster register. If an inappropriate value is set, operations may not be correct. Data bits 7 is unused; they should be set to 0 when written to.

Data bit	7	6	5	4	3	2	1	0
Set value	D7	D6	D5	D4	D3	D2	D1	D0

Figure 7 Display Memory Access Register (R4)

HD66420

Data bit	7	6	5	4	3	2	1	0
Set value	0	ST6	ST5	ST4	ST3	ST2	ST1	ST0

Figure 8 Display Start Raster register (R5)

Data bit	7	6	5	4	3	2	1	0
Set value	0	BSL6	BSL5	BSL4	BSL3	BSL2	BSL1	BSL0

Figure 9 Blink Start Raster register (R6)

Data bit	7	6	5	4	3	2	1	0
Set value	0	BEL6	BEL5	BEL4	BEL3	BEL2	BEL1	BEL0

Figure 10 Blink End Raster register (R7)

Blink Registers (R8 to R10): The blink bit registers (figure 11) designate the 8-bit groups to be blinked. Setting a bit to 1 blinks the corresponding 8-bit group. Any number of groups can be blinked; setting all the bits to 1 will blink the entire LCD panel. These bits are valid only when the BLK bit of control register 2 is 1. R10's data bits 7 to 4 are unused; they should be set to 0 when written to.

Partial Display Block Register (R11): The Partial display block register (figure 12) designates the block of partial display. Data bits 7 and 4 are unused; they should be set to 0 when written to.

Gray Scale Palette Registers (R12 to R15): The gray scale palette registers (figure 13) designate the grayscale level or colour. Use these registers to enable an optimal grayscale or colour display. If GRAY bit is 1, these registers are inactive. Data bits 7 to 5 are unused; they should be set to 0 when written to.

	Data bit	7	6	5	4	3	2	1	0
R8	Set value	BK0	BK1	BK2	BK3	BK4	BK5	BK6	BK7
R9	Set value	BK8	BK9	BK10	BK11	BK12	BK13	BK14	BK15
R10	Set value	0	0	0	0	BK16	BK17	BK18	BK19

Figure 11 Blink Registers (R8, R9, R10)

Data bit	7	6	5	4	3	2	1	0
Set value	0	0	0	0	PB3	PB2	PB1	PB0

Figure 12 Partial Display Start Raster Register (R11)

Table 1 Partial Display Start Raster Register (R11)

Set value	Row no.	Set value	Row no.	(ADC= "0". If "1", reverse direction)
H'00	COM1 to COM8	H'05	COM80 to COM73	
H'01	COM9 to COM16	H'06	COM72 to COM65	
H'02	COM17 to COM24	H'07	COM64 to COM57	
H'03	COM25 to COM32	H'08	COM56 to COM49	
H'04	COM33 to COM40	H'09	COM48 to COM41	

	Data bit	7	6	5	4	3	2	1	0
R12	Set value	0	0	0	GP14	GP13	GP12	GP11	GP10
R13	Set value	0	0	0	GP24	GP23	GP22	GP21	GP20
R14	Set value	0	0	0	GP34	GP33	GP32	GP31	GP30
R15	Set value	0	0	0	GP44	GP43	GP42	GP41	GP40

Figure 13 Grayscale Palette Registers (R12 to R15)

Contrast Control and LCD Alternative Drive Cycle Register (R16): The contrast control register (figure 14) designates the contrast level of LCD display. These bits change the voltage which is supplied to LCD drivers.

The LCD alternative drive cycle register designates the number of lines that LCD drive outputs are alternated.

Data bits 7 is unused; they should be set to 0 when written to.

HD66420

Table 2 Grayscale Levels

GP14	GP13	GP12	GP11	GP10	Gray scale Level	GP14	GP13	GP12	GP11	GP10	Gray scale Level
GP24	GP23	GP22	GP21	GP20		GP24	GP23	GP22	GP21	GP20	
GP34	GP33	GP32	GP31	GP30		GP34	GP33	GP32	GP31	GP30	
GP44	GP43	GP42	GP41	GP40		GP44	GP43	GP42	GP41	GP40	
0	0	0	0	0	0	1	0	0	0	0	16/31
				1	1/31					1	17/31
			1	0	2/31				1	0	18/31
				1	3/31					1	19/31
		1	0	0	4/31			1	0	0	20/31
				1	5/31					1	21/31
			1	0	6/31				1	0	22/31
				1	7/31					1	23/31
	1	0	0	0	8/31		1	0	0	0	24/31
				1	9/31					1	25/31
			1	0	10/31				1	0	26/31
				1	11/31					1	27/31
		1	0	0	12/31			1	0	0	28/31
				1	13/31					1	29/31
			1	0	14/31				1	0	30/31
				1	15/31					1	1

Table 3 LCD alternative drive cycle

CM1	CM0	Alternative Cycle
0	0	Frame
0	1	7 lines
1	0	11 lines
1	1	13 lines

Data bit	7	6	5	4	3	2	1	0
Set value	0	CM1	CM0	CC4	CC3	CC2	CC1	CC0

Figure 14 Contrast Control register (R16)

Figure 15 shows characteristics of the LCD effective value against grayscale. This value is almost linear at all grayscale range without LCD panel. This linearity will be lost if LCD panel is connected. In this case, the four appropriate levels must be selected from grayscale No.1 to 31.

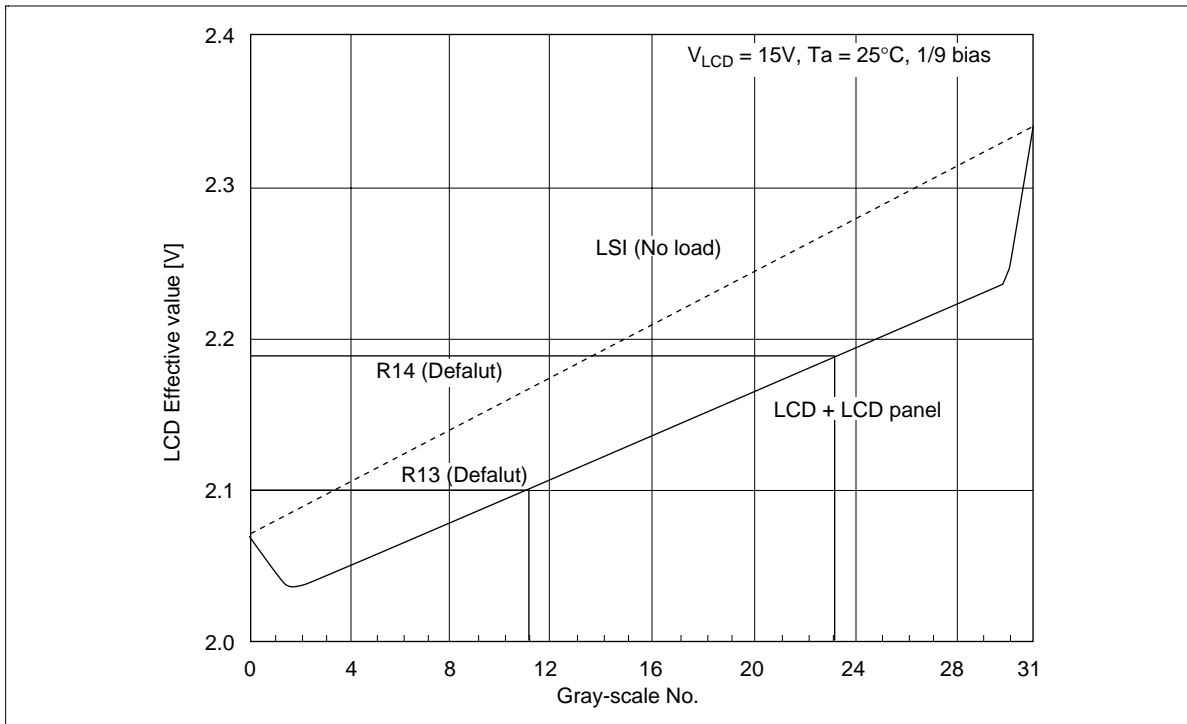

Figure 15 LCD Effective Value

HD66420

Register List

CS	RS	Index Reg.Bits					Register Name	R/W	Data bits											
		4	3	2	1	0			7	6	5	4	3	2	1	0				
1	-	-	-	-	-	-	-													
0	0	-	-	-	-	IR	Index register	W					IR4	IR3	IR2	IR1	IR0			
0	1	0	0	0	0	R0	Control register 1	W	RMW	DISP	STBY	PWR	AMP	REV	HOLT	ADC				
0	1	0	0	0	0	R1	Control register 2	W	BIS1	BIS0	WLS	GRAY	DTY1	DTY0	INC	BLK				
0	1	0	0	0	1	R2	X address register	W				XA5	XA4	XA3	XA2	XA1	XA0			
0	1	0	0	0	1	R3	Y address register	W			YA6	YA5	YA4	YA3	YA2	YA1	YA0			
0	1	0	0	1	0	R4	Display RAM access register	R/W	D7	D6	D5	D4	D3	D2	D1	D0				
0	1	0	0	1	0	R5	Display start line register	W		ST6	ST5	ST4	ST3	ST2	ST1	ST0				
0	1	0	0	1	1	R6	Blink start line register	W		BSL6	BSL5	BSL4	BSL3	BSL2	BSL1	BSL0				
0	1	0	0	1	1	R7	Blink end line register	W		BEL6	BEL5	BEL4	BEL3	BEL2	BEL1	BEL0				
0	1	0	1	0	0	R8	Blink register 1	W	BK0	BK1	BK2	BK3	BK4	BK5	BK6	BK7				
0	1	0	1	0	0	R9	Blink register 2	W	BK8	BK9	BK10	BK11	BK12	BK13	BK14	BK15				
0	1	0	1	0	1	R10	Blink register 3	W					BK16	BK17	BK8	BK9				
0	1	0	1	0	1	R11	Partial display block register	W					PB3	PB2	PB1	PB0				
0	1	0	1	1	0	R12	Gray scale palette 1 (0, 0)	W					GP14	GP13	GP12	GP11	GP10			
0	1	0	1	1	0	R13	Gray scale palette 2 (0, 1)	W					GP24	GP23	GP22	GP21	GP20			
0	1	0	1	1	0	R14	Gray scale palette 3 (1, 0)	W					GP34	GP33	GP32	GP31	GP30			
0	1	0	1	1	1	R15	Gray scale palette 4 (1, 1)	W					GP44	GP43	GP42	GP41	GP40			
0	1	1	0	0	0	R16	Contrast control register	W		CM1	CM0	CC4	CC3	CC2	CC1	CC0				
0	1	1	0	0	1	R17	Reserved	-												
0	1	1	0	0	1	R18	Reserved	-												
0	1	1	0	0	1	R19	Reserved	-												
0	1	1	0	1	0	R20	Reserved	-												
0	1	1	0	1	0	R21	Reserved	-												
0	1	1	0	1	0	R22	Reserved	-												
0	1	1	0	1	1	R23	Reserved	-												
0	1	1	1	0	0	R24	Reserved	-												
0	1	1	1	0	0	R25	Reserved	-												
0	1	1	1	0	1	R26	Reserved	-												
0	1	1	1	0	1	R27	Reserved	-												
0	1	1	1	1	0	R28	Reserved	-												
0	1	1	1	1	0	R29	Reserved	-												
0	1	1	1	1	0	R30	Reserved	-												
0	1	1	1	1	1	R31	Reserved	-												

MPU Interface

The HD66420 can interface directly to an MPU through an 8-bit data bus (figure 16). The MPU can access the HD66420 internal registers independently of internal clock timing.

The index register can be directly accessed but the other registers (data registers) cannot. Before accessing a data register, its register number must be written to the index register. Once written, the register number is held until it is rewritten, enabling the same register to be consecutively accessed without having to rewrite to the register number for each access. An example of a register access sequence is shown in figure 17.

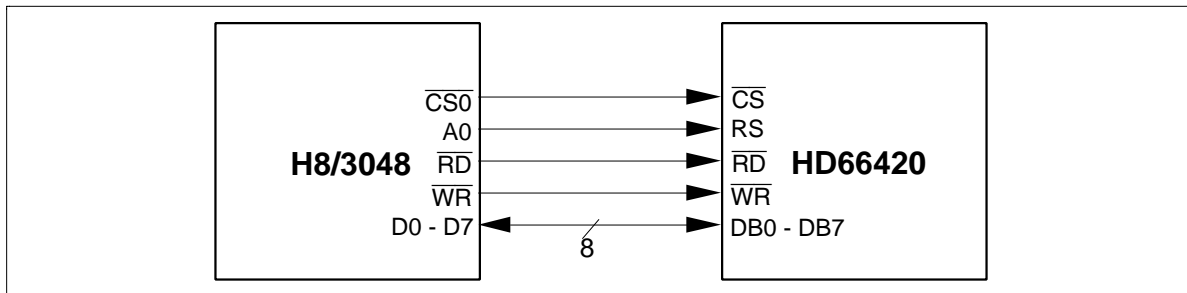

Figure 16 Example of 8-bit MPU Interface

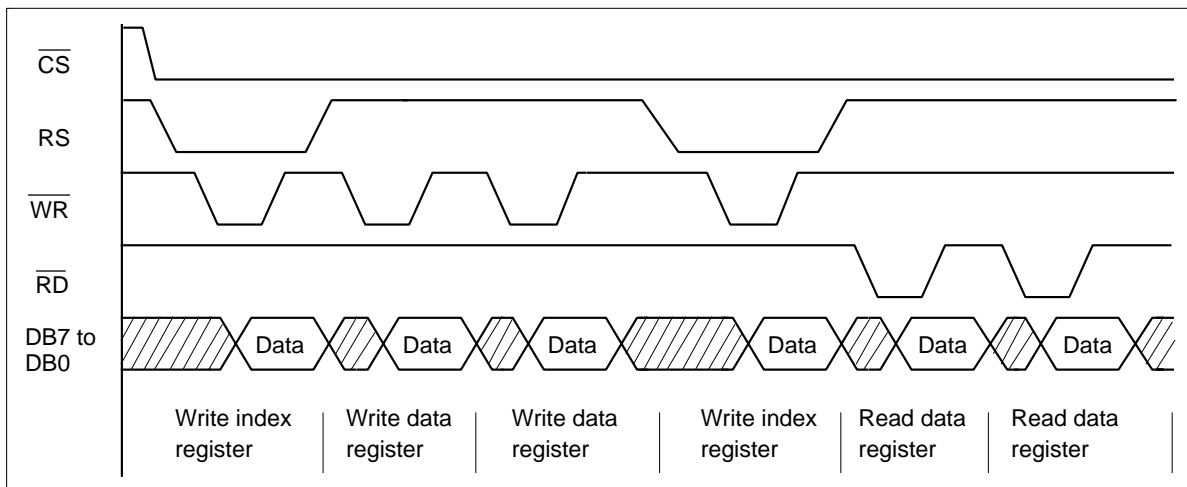

Figure 17 8-Bit Data Transfer Sequence

HD66420

LCD Driver Configuration

HD66420 outputs 160 segment and 100 common signals. The same number of common signal is output from both sides, 40 signals for 1/80 duty ratio and 32 signals for 1/64 duty ratio. In the case of 1/64 and 1/48 duty ratio, unused terminals output nondisplay levels.

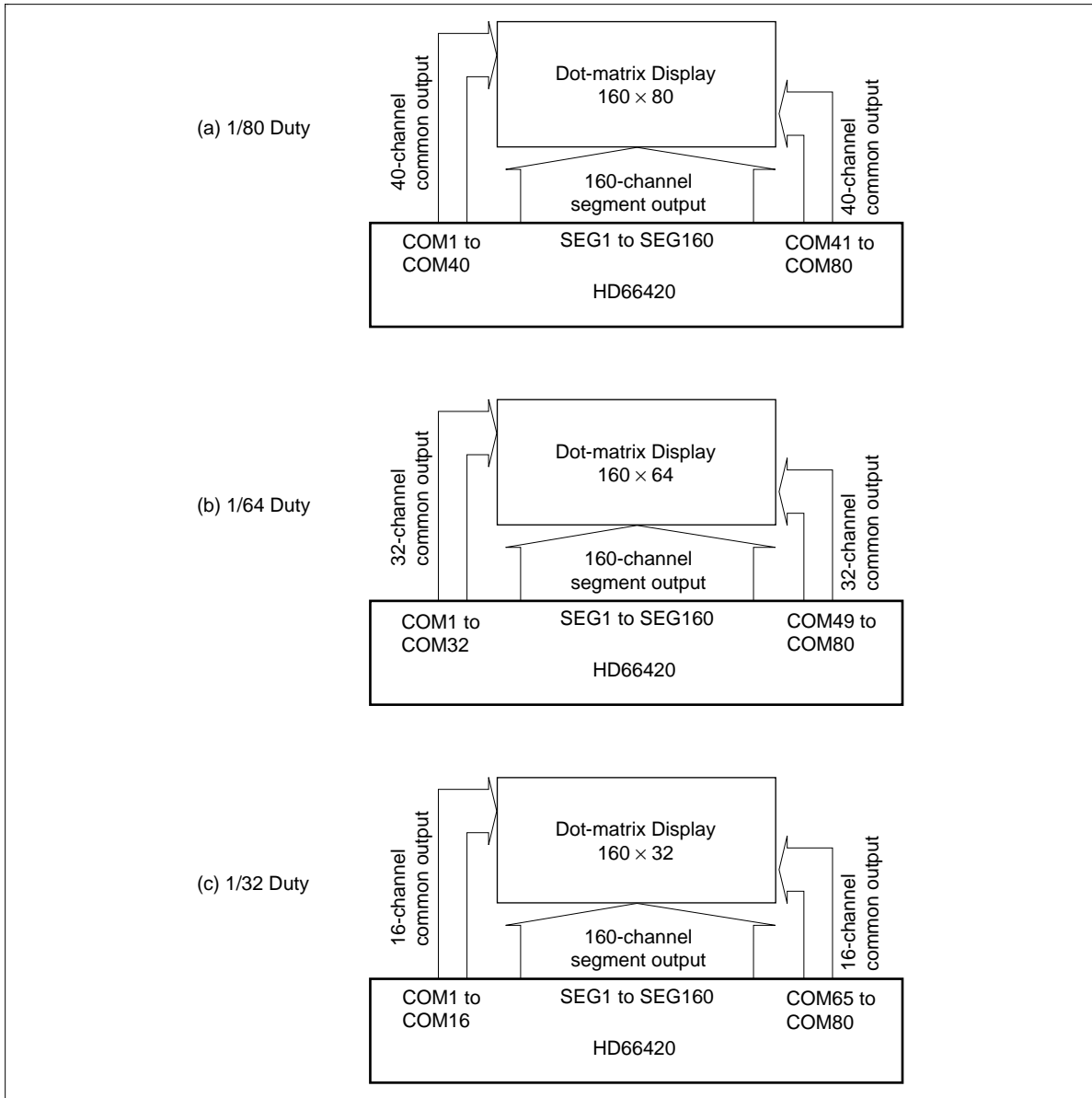

Figure 18 Common and Segment Outputs

Column Address Inversion According to LCD Driver Layout: The HD6420 can always display data in address H'0 on the top left of an LCD panel regardless of where it is positioned with respect to the panel. This is because the HD66420 can invert the positional relationship between display RAM addresses and LCD driver output pins by inverting RAM addresses. Specifically, the HD66420 outputs data in address H'0 from SEG1 when the ADC bit in control register 1 is 0, and from SEG160 otherwise. Here, the scan direction of common output is also inverted according to the situation as shown in figure 19. Note that addresses and scan direction are inverted when data is written to the display RAM, and thus changing the ADC bit after data has been written has no effect. Therefore, hardware control bits such as ADC must be set immediately after reset is canceled, and must not be set while data is being displayed.

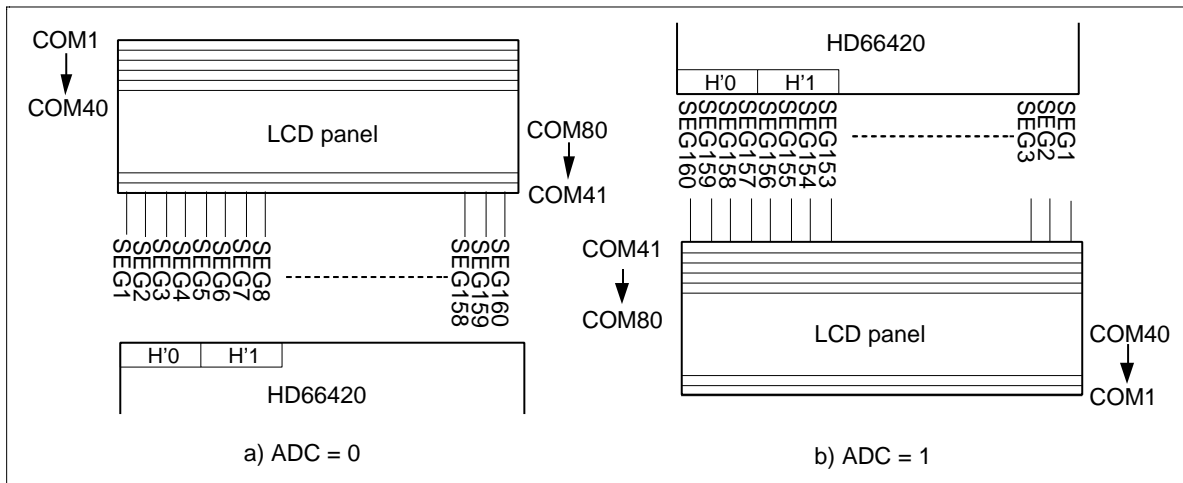

Figure 19 LCD Driver Layout and RAM addresses : 1/80 Duty cycle

Table 4 Scanning Direction and RAM Address

DTY1	DTY0	ADC	COMMON	SEGMENT
0	0	0	COM1 → COM40, COM80 → COM41	H'00 → SEG1
		1	COM41 → COM80, COM40 → COM1	H'00 → SEG160
	1	0	COM1 → COM32, COM80 → COM49	H'00 → SEG1
		1	COM49 → COM80, COM32 → COM1	H'00 → SEG160
1	0	0	COM1 → COM16, COM80 → COM65	H'00 → SEG1
		1	COM65 → COM80, COM16 → COM1	H'00 → SEG160
	1	0	8 COM depend on R11	H'00 → SEG1
		1	8 COM depend on R11	H'00 → SEG160

HD66420

Multi-LSI Operation

Using multiple HD66420s provides the means for extending the number of display dots. Note the following items when using the multi-LSI operation.

- (1) The master LSI and the slave LSI must be determined; the M/S pin of the master LSI must be set high and the M/S pin of the slave LSI must be set low.
- (2) The master LSI supplies the FLM, M, CL1 and clock signals to the slave LSI via the corresponding pins, which synchronizes the slave LSI with the master LSI.
- (3) All control bits of slave LSI must be set with the same data with that of the master LSI.
- (4) All LSIs must be set to LCD off in order to turn off the display.
- (5) The standby function of slave LSI must be started up first, and that of the master LSI must be terminated first.
- (6) The power supply circuit of slave LSI stop working, so V1 to V5 levels are supplied from the master LSI. If the internal power supply circuit can not drive two LSIs, use an external power supply circuit.

Figure 20 shows the configuration using two HD66420s and table 2 lists the differences between master and slave modes.

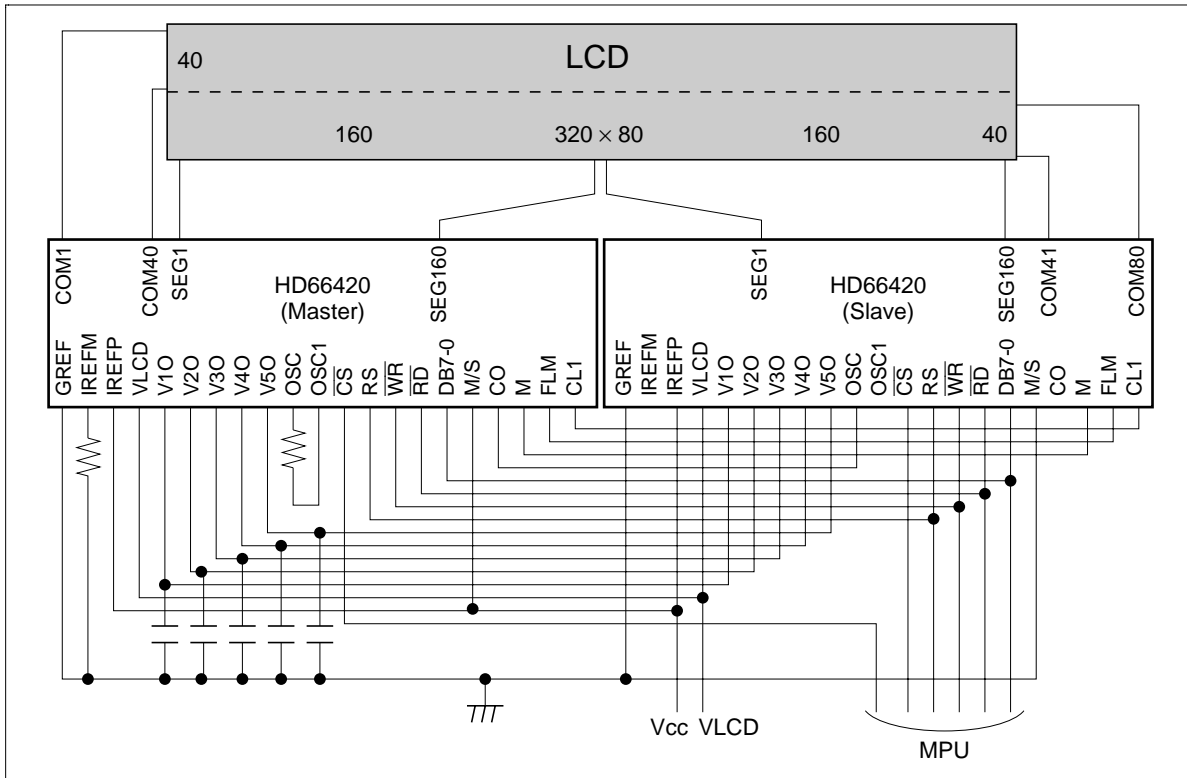

Figure 20 Configuration Using Two HD66420s for 320 × 80 dots LCD

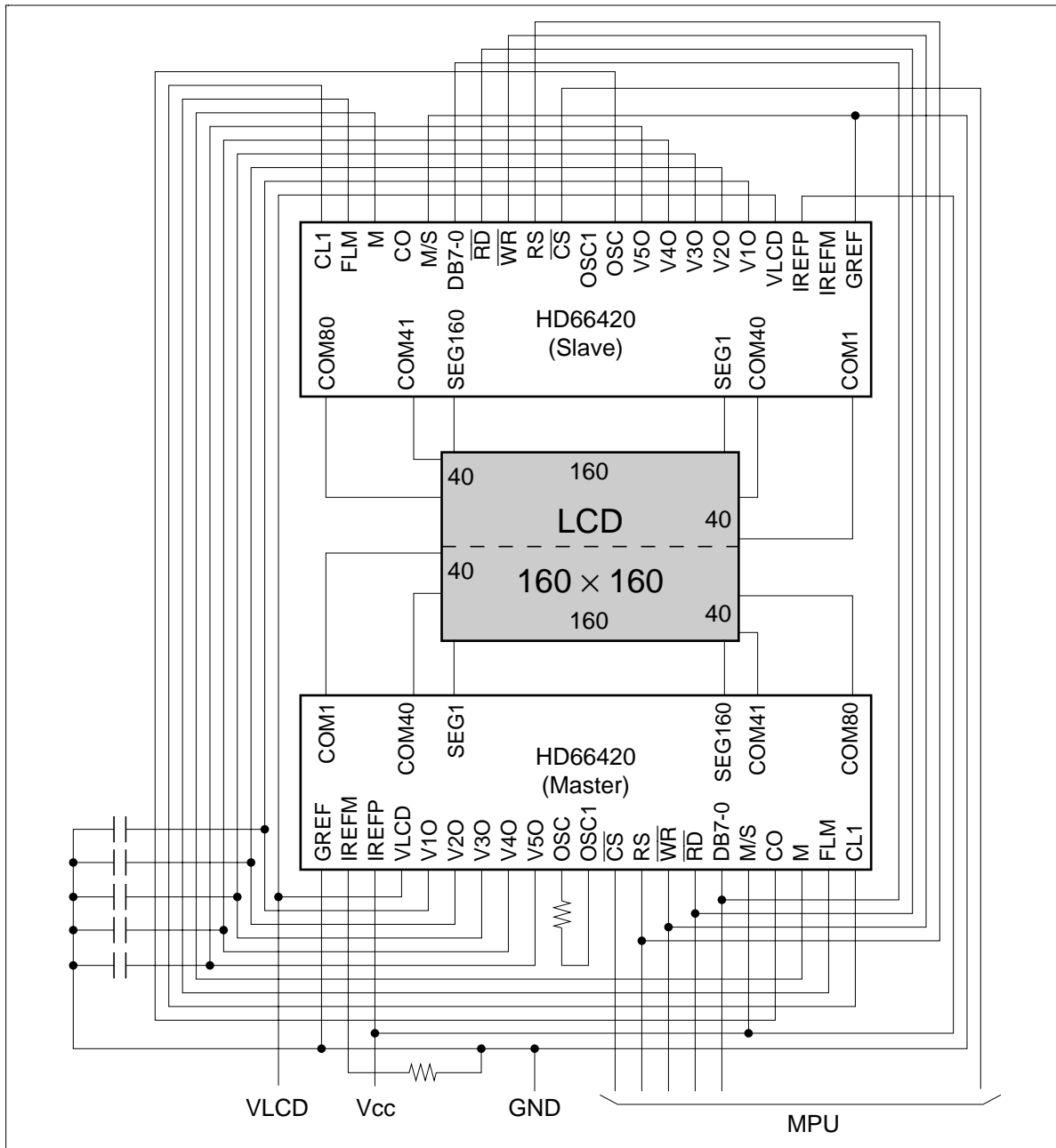

Figure 21 Configuration Using Two HD66420s for 160 × 160 dots LCD

HD66420

Table 5 Comparison between Master and Slave Modes

Item		Master Mode	Slave Mode
Pin	M/S	Must be set high	Must be set low
	OSC	Oscillation is active	Supply from master's CO
	CO	Output	High-Z
	FLM, M, CL1	Output signals	Input signals from Master LSI
Registers	R0, R2 to R15	Valid	Valid
	R1: BIS1, 0	Valid	Invalid
	R1: other	Valid	Valid
	R16	Valid	Invalid
Power supply circuit		Valid	Stop working. All signals are supplied from master LSI or external power circuit.

Display RAM Configuration and Display

The HD66420 incorporates a bit-mapped display RAM. It has 320 bits in the X direction and 80 bits in the Y direction. The 320 bits are divided into forty 8-bit groups. As shown in figure 22, data written by the MPU is stored horizontally with the MSB at the far left and the LSB at the far right. The consecutive two bits control one pixel of LCD, this means that one 8-bits data contains data which controls four pixels.

The ADC bit of control register 1 can control the positional relationship between X addresses of the RAM and LCD driver output (figure 23). Specifically, the data in address H'0 is output from SEG1 when the ADC bit in control register 1 is 0, and from SEG160 otherwise. Here, data in each 8-bit group is also inverted. Because of this function, the data in X address H'0 can be always displayed on the top left of an LCD panel with the MSB at the far left regardless of the LSI is positioned with respect to the panel. In this case, DB7, DB5, DB3 and DB1 are more significant bit in consecutive two bits.

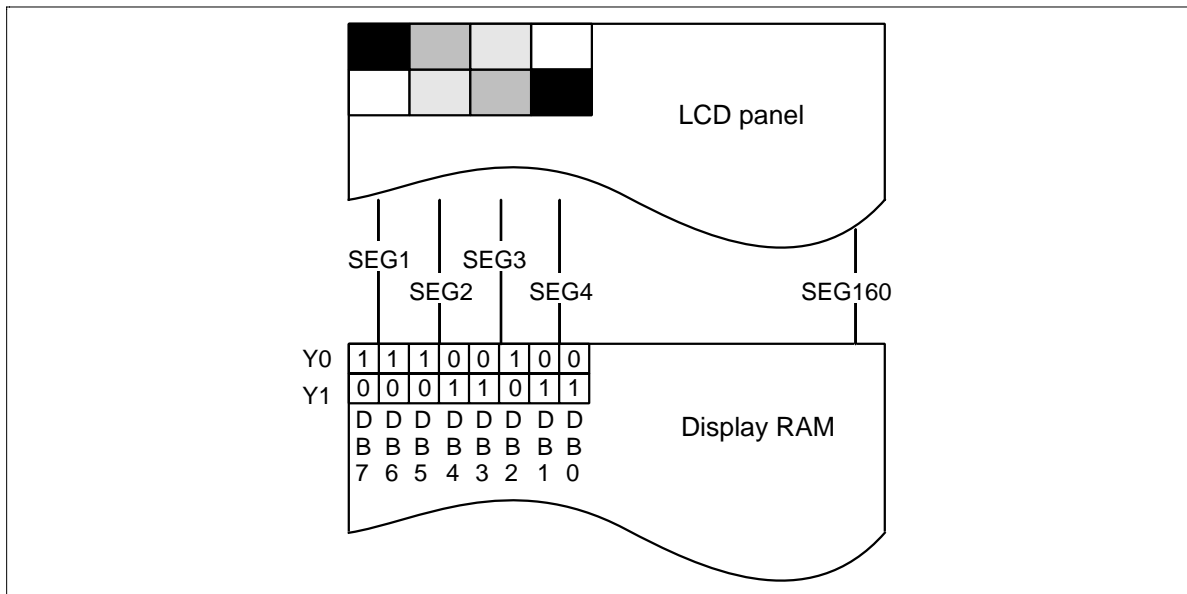

Figure 22 Display RAM Data and Display

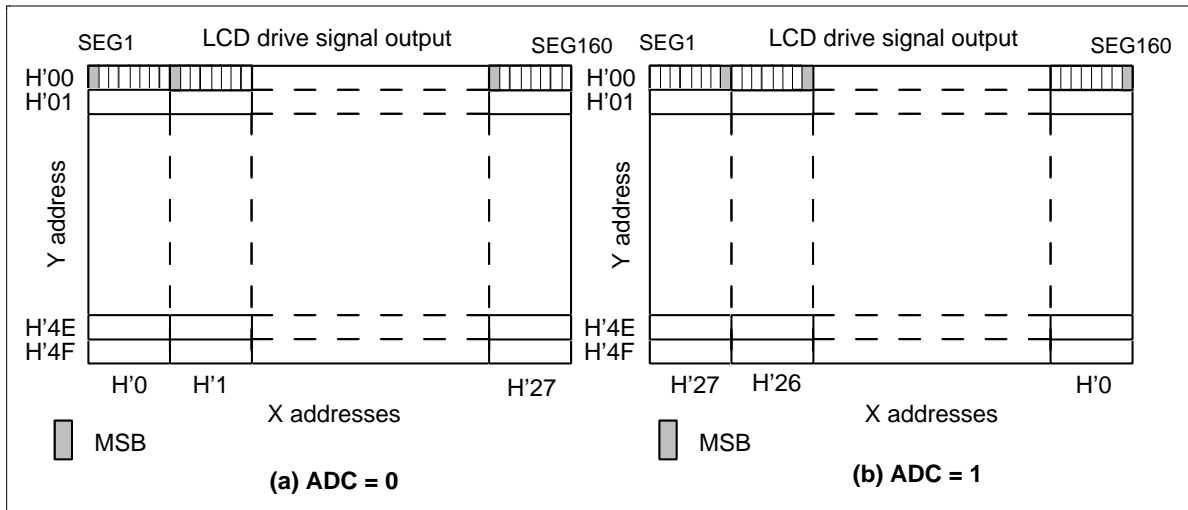

Figure 23 Display RAM Configuration

Word Length

The HD66420 can handle either 8- or 6-bits as a word. In the display memory, one X address is assigned to each word of 8- or 6-bits long in X direction.

When the 6-bits mode is selected, only data on DB5 to DB0 are used and data on DB7 and DB6 are discarded. This word length is only applied to data to internal RAM. The word length of internal register is always 8-bits

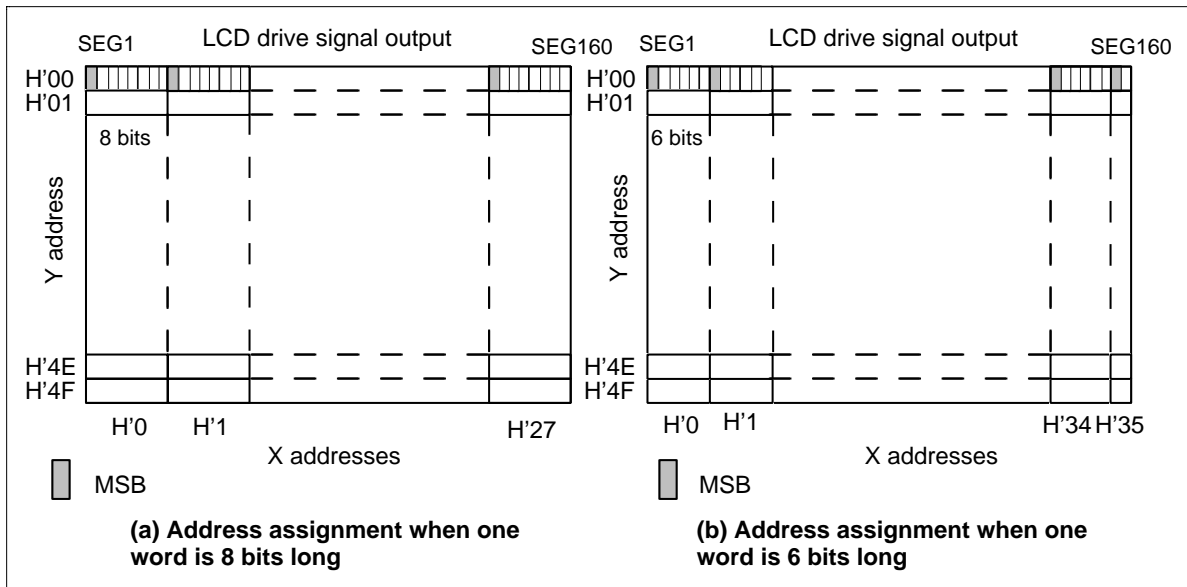

Figure 24 Display RAM Addresses

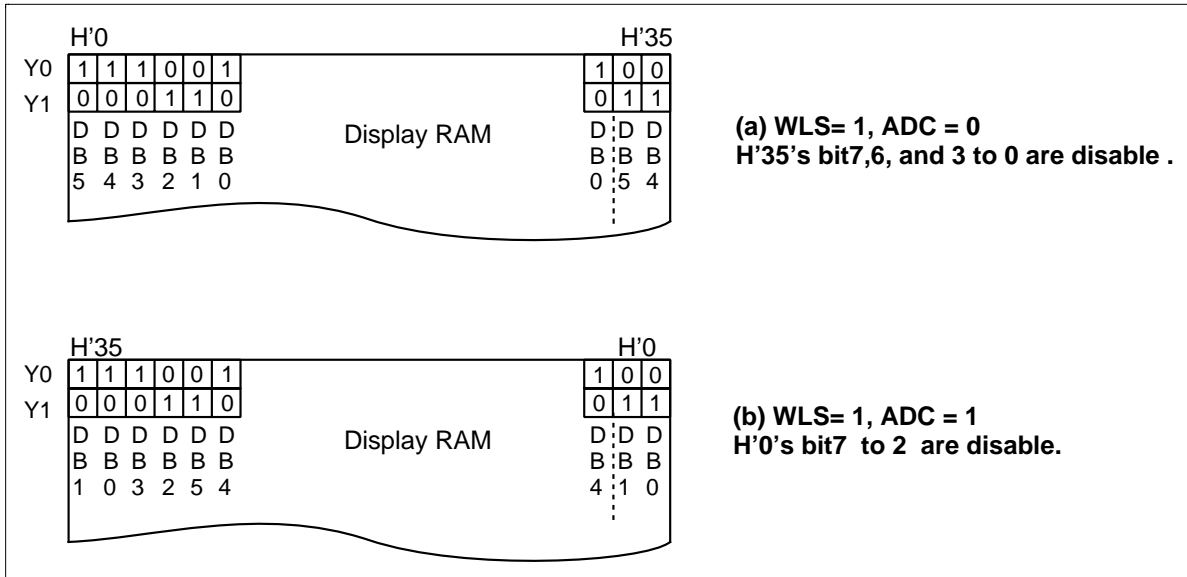

Figure 25 Display RAM Bits Map

Configuration of Display Data Bit

Packed Pixel Method

For grey scale display and super reflective colour display, multiple bits are needed for one pixel. In the HD66420, two bits are assigned to one pixel, enabling a four-level grey scale display and four colour display.

One address, eight bits, specifies four pixels, and pixel bits 0 and 1 for gray scale are managed as consecutive bits in one byte.

When grey scale display data is manipulated in bit units, one memory access is sufficient, which enables smooth high-speed data rewriting.

The bit data to input to pin DB7, DB5, DB3 and DB1 become MSB and the bit data to input via pin DB6, DB4, DB2 and DB0 are LSB.

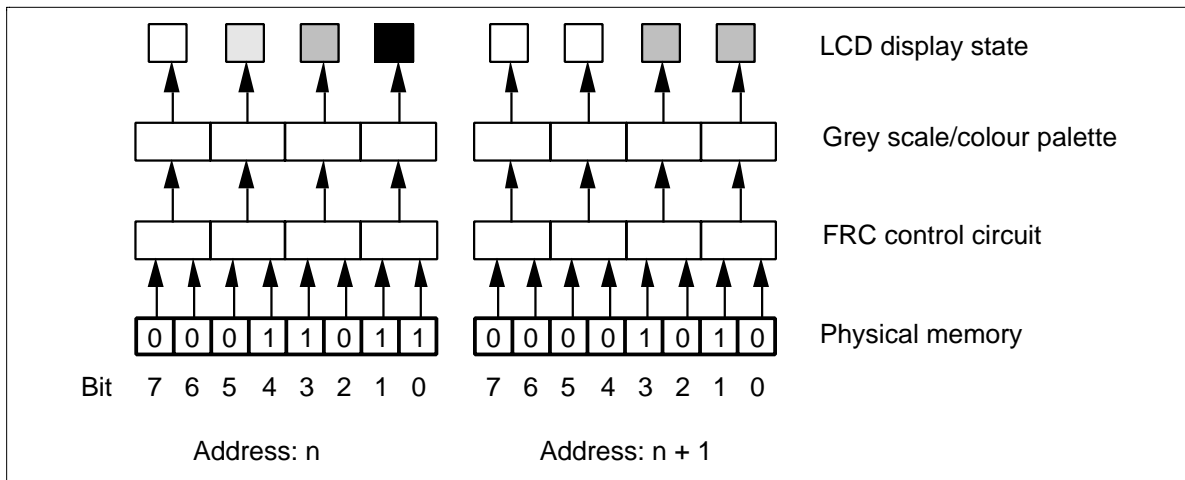

Figure 26 Packed Pixel Method

HD66420

Gray scale/Colour palette

The HD66420 uses PWM, Pulse Width Modulation, technique for gray scale display. A period of one line is divided into thirty-one or four and HD66420 outputs turn-on levels for one period and turn-off levels for rest of these period. This technique changes gray scale on monochrome display and colour on super reflective colour panel. The characteristics of these panel vary with different panel. To allow for this, the HD66420 designed to generate 32-levels gray scale levels and provides palette registers that assign desired levels to certain of the four colours, GRAY = 0, or generate dedicated 4-level grayscale , GRAY = 1. Using the palette registers to select any 4 out of 32 levels of applied voltages enables an optimal grayscale/colour display. Because of this grayscale technique using 32-levels gray scale needs higher clock rate. If 32-levels gray scale is not needed, lower clock rate can be used. Table 6 shows default value of palette registers and Table 7 and 8 show relationship between value of a palette register and grayscale level.

Table 6 Default Value of Palette Registers

DB7, 5, 3, 1	DB6, 4, 2, 0	Register Name	Default Value				
0	0	Grayscale Palette 1	0	0	0	0	0
	1	Grayscale Palette 2	0	1	0	1	1
1	0	Grayscale Palette 3	1	0	1	1	1
	1	Grayscale Palette 4	1	1	1	1	1

Table 7 Value of a Palette Register and Grayscale Levels (GRAY= 0)

Value					Grayscale Level	Note
0	0	0	0	0	0	default R12
				1	1/31	
		1	0	0	2/31	
				1	3/31	
	1	0	0	0	4/31	
				1	5/31	
		1	0	0	6/31	
				1	7/31	
1	0	0	0	0	8/31	
				1	9/31	
		1	0	0	10/31	
				1	11/31	default R13
	1	0	0	0	12/31	
				1	13/31	
		1	0	0	14/31	
				1	15/31	
1	0	0	0	0	16/31	
				1	17/31	
		1	0	0	18/31	
				1	19/31	
	1	0	0	0	20/31	
				1	21/31	
		1	0	0	22/31	
				1	23/31	default R14
1	0	0	0	0	24/31	
				1	25/31	
		1	0	0	26/31	
				1	27/31	
	1	0	0	0	28/31	
				1	29/31	
		1	0	0	30/31	
				1	1	default R15

HD66420

Table 8 Grayscale Levels (GRAY= 1)

DB7, 5, 3, 1	DB6, 4, 2, 0	Grayscale Level
0	0	0
	1	1/3
1	0	2/3
	1	1

Access to Internal Registers and Display RAM

Access to Internal Registers by the MPU: The internal registers include the index register and data registers. The index register can be accessed by driving both the \overline{CS} and RS signals low. To access a data register, first write its register number ID to the index register with RS set to 0, and then access the data register with RS set to 1. Once written, the register number is held until it is rewritten, enabling the same register to be consecutively accessed without having to rewrite to the register number for each access. Some data registers contain unused bits; they should be set to 0. Note that all data registers except the display memory access register can only be written to.

Access to Display RAM by the MPU: To access the display RAM, first write the RAM address desired to the X address register (R2) and the Y address register (R3). Then read/write the display memory access register (R4). Memory access by the MPU is independent of memory read by the HD66420 and is also asynchronous with the HD66420's clock, thus enabling an interface independent of HD66420's internal operations.

However, when reading data is temporarily latched into a HD66420's buffer and then output next time, a read is performed in a subsequent cycle. This means that a dummy read is necessary after setting X and Y addresses. The memory read sequence is shown in figure 27.

X and Y addresses are automatically incremented after each memory access according to the INC bit value in control register 2; therefore, it is not necessary to update the addresses for each access. Figure 28 shows two cases of incrementing display RAM address. When the INC bit is 0, the Y address will be incremented up to H'7F with the X address unchanged. However, actual memory is valid only within H'00_ to H'4F; accessing an invalid address is ignored. When the INC bit is 1, the X address will be incremented up to H'27 or H'35 according to WLS bit with the Y address unchanged. After address H'27 or H'35 is accessed, the X address will be returned to H'00; accessing more than forty bytes causes rewriting to the same address.

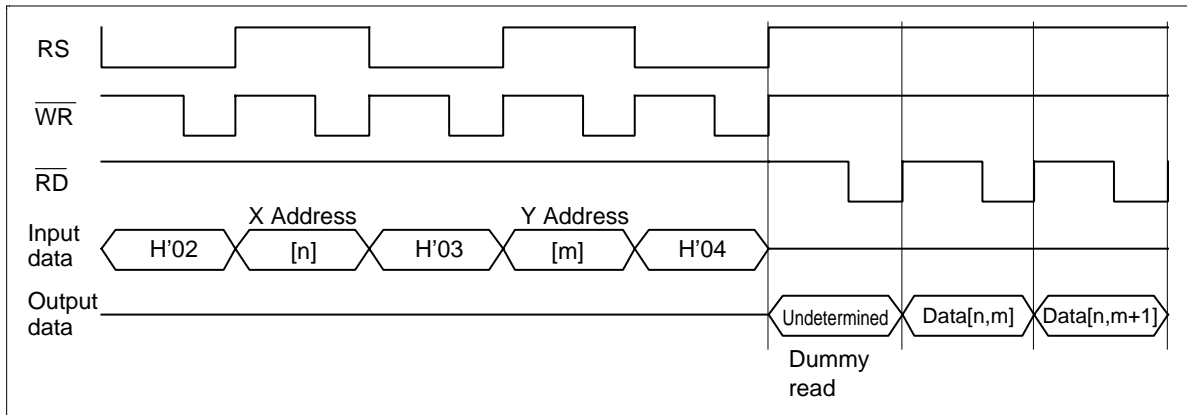

Figure 27 Display RAM read sequence

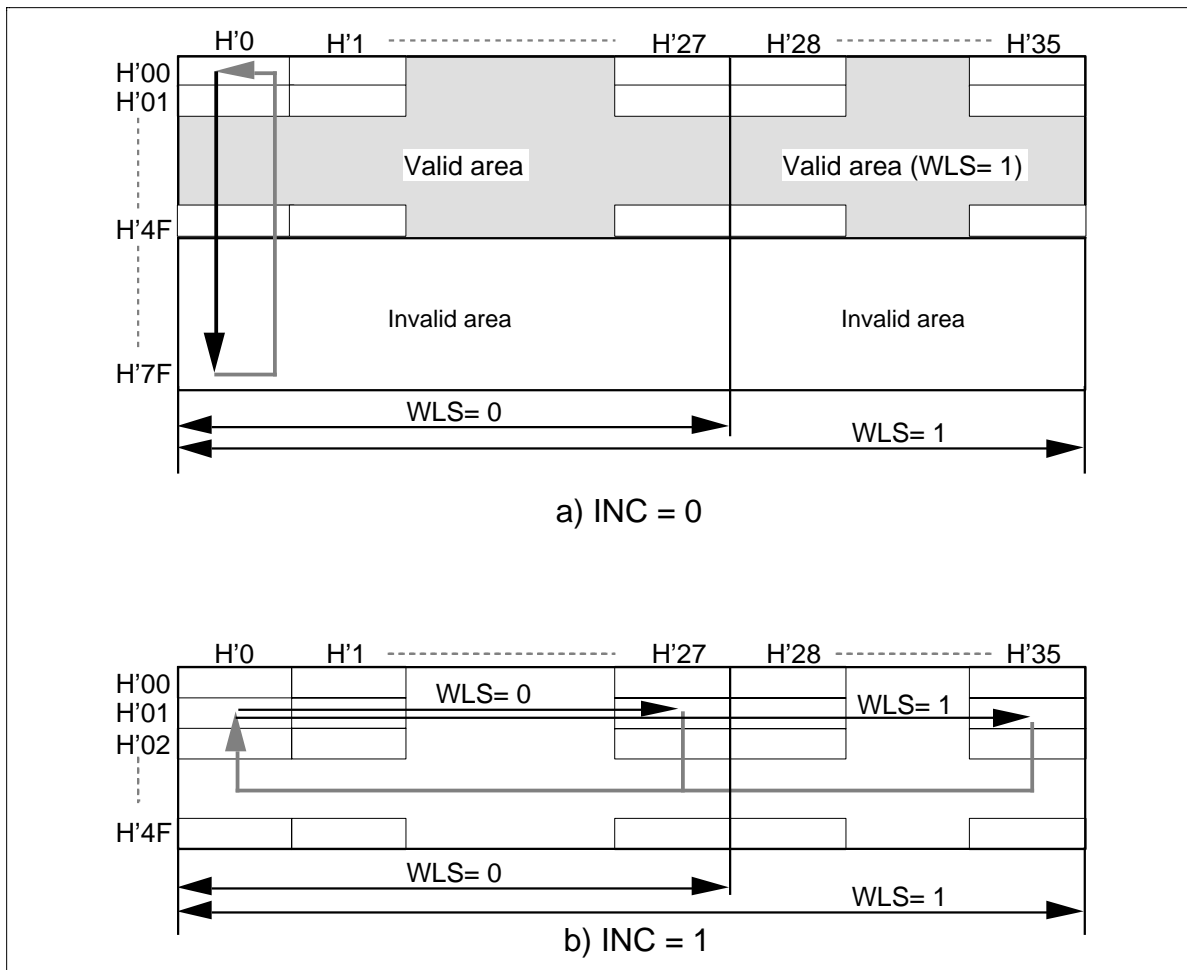

Figure 28 Display Address Increment

HD66420

Arbitration Control

The HD66420 controls the arbitration between draw access and display access. The draw access read and write display data of display memory incorporated in the HD66420. The display access outputs display data to the liquid crystal panel. The draw access has the priority enabled without having the system to wait. For arbitration control, draw access is recognized as valid when \overline{CS} and $\overline{WR}/\overline{RD}$ are low. When draw and display access occur at the same time, draw access is executed prior to display access. Display access is executed between two draw access during display access period. If a period of one draw access is longer than that of display access, display access will not be executed properly. If this condition happens frequently, flicker will be seen on the display. The low level width of \overline{WR} and \overline{RD} must be less than the period of display access - 450 ns.

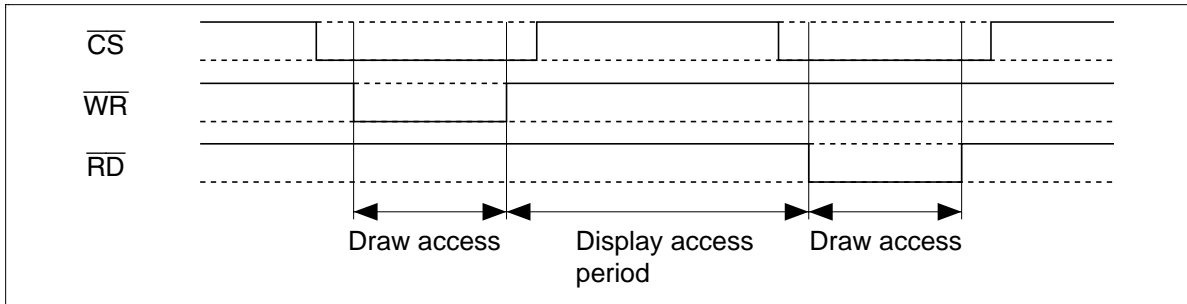

Figure 29 Definition of Draw Access

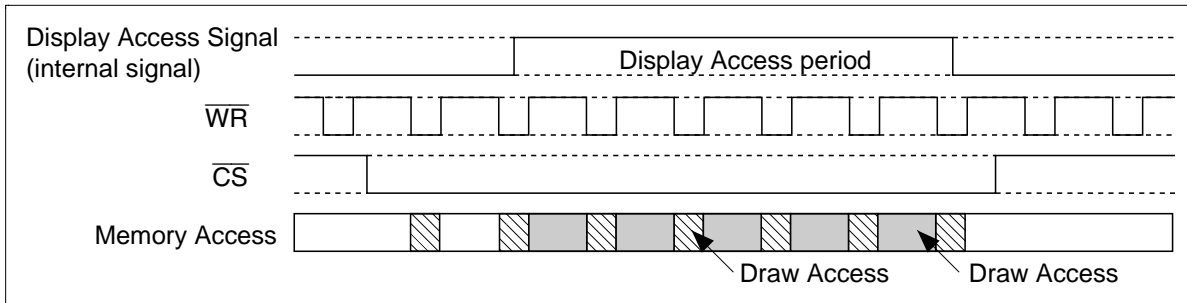

Figure 30 Memory Access when Display and Draw Access Occur at The Same Time

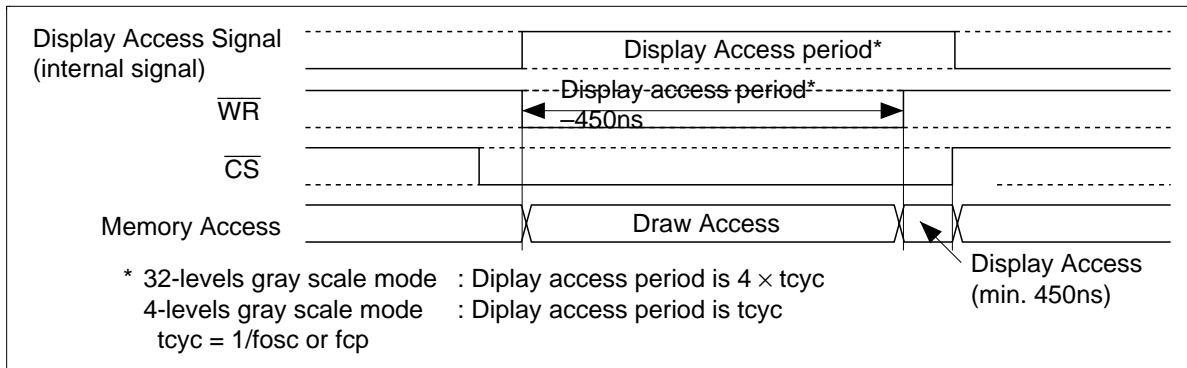

Figure 31 $\overline{\text{WR}}$ Low Level Width

HD66420

Read-Modify-Write: X- or Y-address is incremented after reading from or writing data to the display RAM at normal mode $RMW=0$. However, X- or Y-address is not incremented after reading data from the display RAM at read-modify-write mode, $RMW=1$. The data which is read from the display RAM may be modified and written to the same address without re-setting the address. Data is temporarily latched into a HD66420's buffer and then output next time a read is performed in a subsequent cycle. This means that the dummy read is necessary after every cycle. This sequence is shown in figure 32.

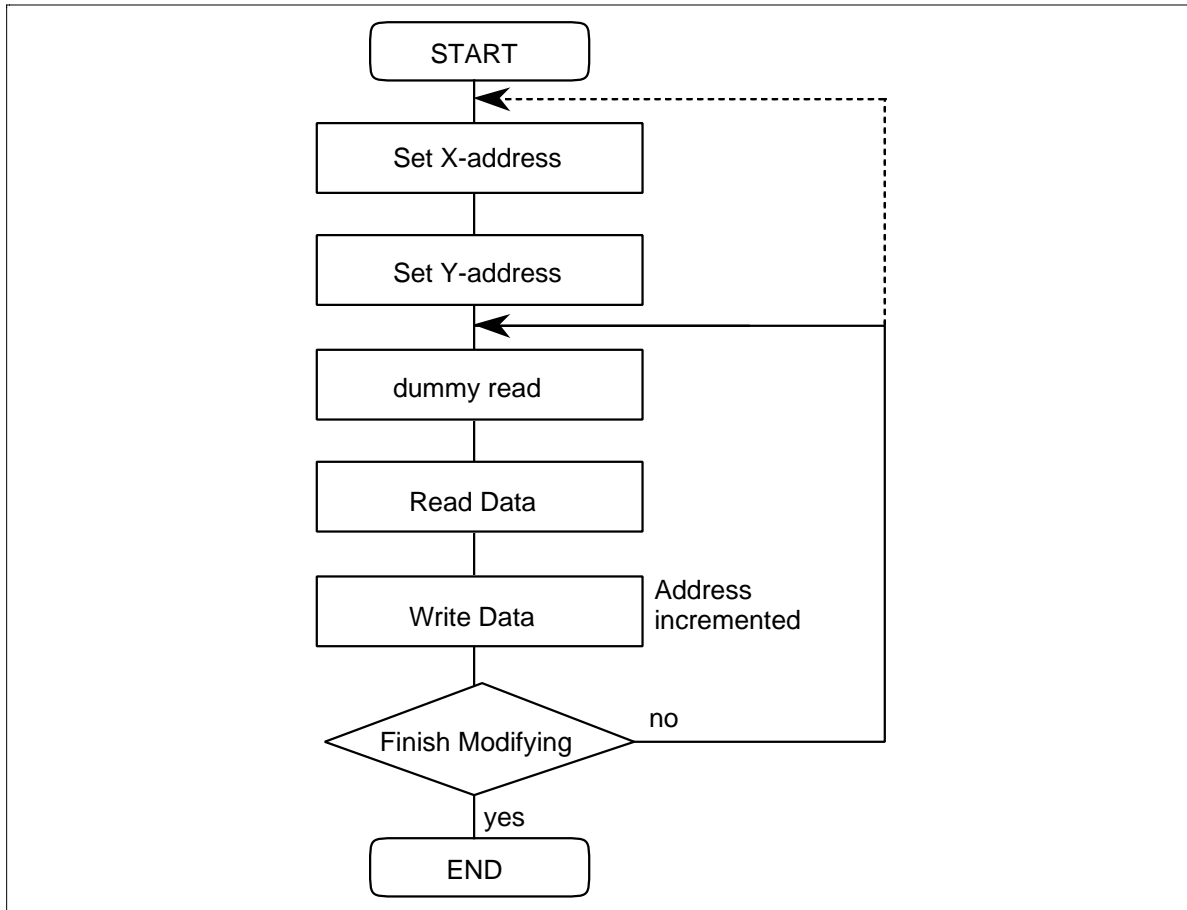

Figure 32 The Flow Chart for Read-Modify-Write

Vertical Scroll Function

The HD66420 can vertically scroll a display by varying the top raster to be displayed which is specified by the display start raster register. Figure 33 and 34 show vertical scroll examples. As shown, when the top raster to be displayed is set to 1, data in Y address H'00 is displayed on the 80th raster. To display another frame on the 80th raster, therefore, data in Y address H'00 must be modified after setting the top raster. When display duty is less than 80, for example 1/64, data of address H'40 is displayed after address H'3F.

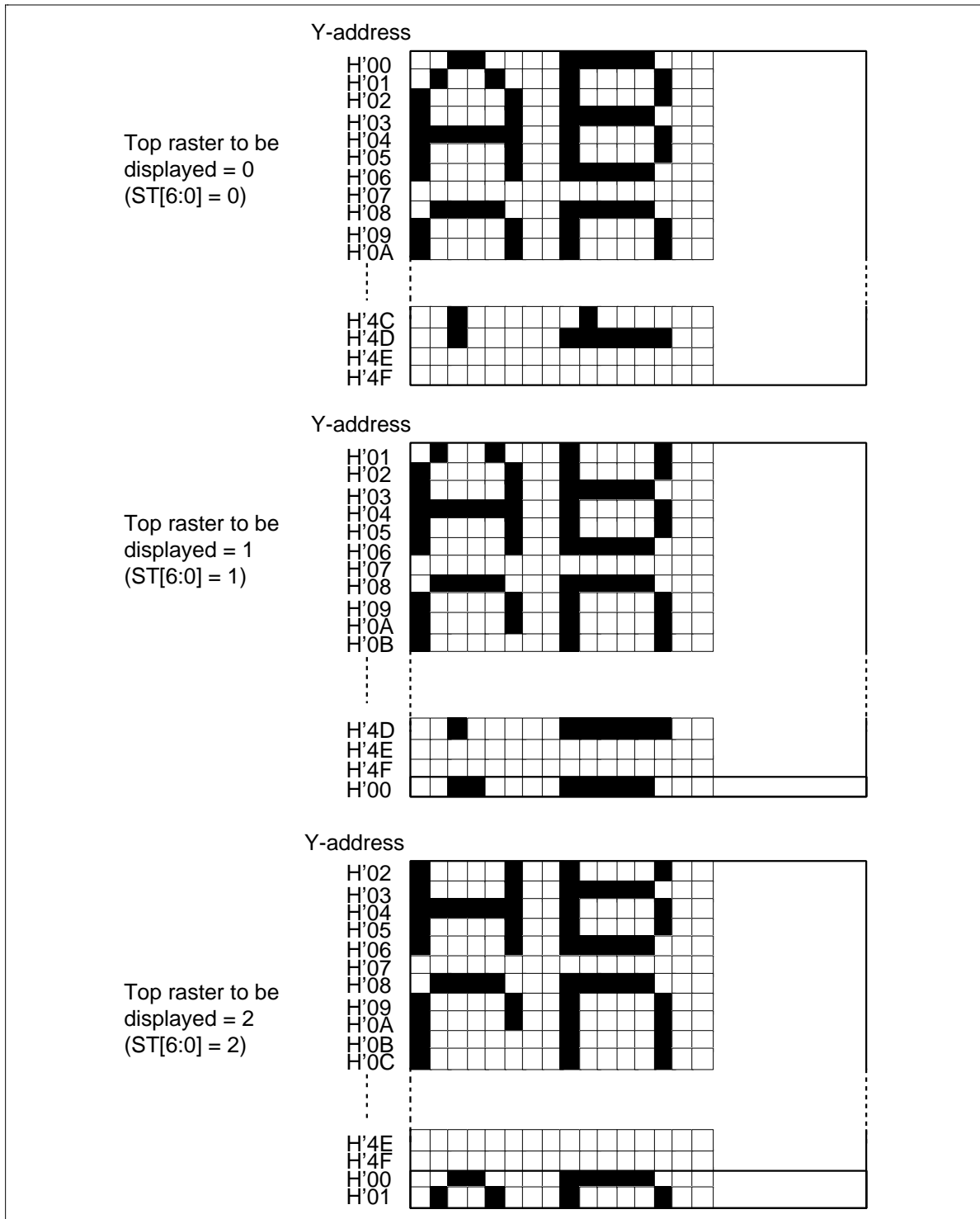

Figure 33 Vertical Scroll : 1/80Duty Cycle

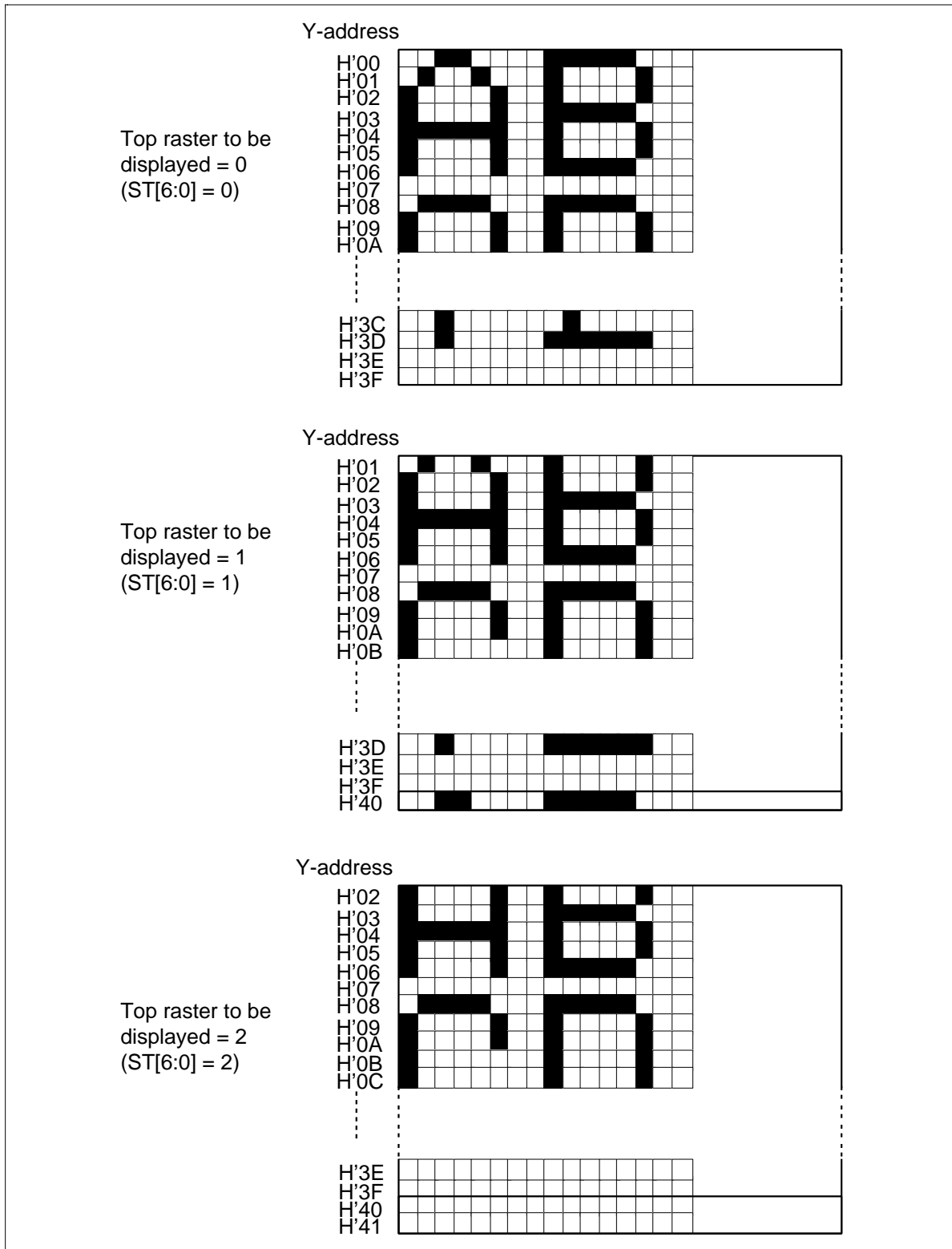

Figure 34 Vertical Scroll : 1/64Duty Cycle

HD66420

Partial Display Function

The HD66420 can display only a part of a full display. The bias ratio of this partial display is 1/4 from V_{CC} to GND, the duty ratio is 1/8 and rest of display is scanned with unselected levels. 8 levels of contrast can be selected with data bit 2 to 0 of R16. The position of this partial display can be located at any position with using partial display position register. To launch this mode, following processes are needed:

- (1) supplied voltage to VLCD must be cut off, PWR bit can be used if external voltage supplier is controlled with DCON output (R0)
- (2) set DTY0, 1 bits (R1)
- (3) set COM scanning direction (ADC bit)
- (4) set display position (R11, R5)
- (5) set contrast level (R16 data-bit 2 to 0)

The clock frequency may be 180kHz at normal display mode. When a partial display is driven, oscillation frequency will be 18kHz, 1/10 of that of normal display mode. This function is useful for lower power dissipation osc-osc2 oscillator is used for the partial display mode, and this switch is done automatically with mode. To change clock frequency, follow the process which is showed in Figure 35.

Warning: VLCD must be cut off when partial display mode is launched. Vcc is supplied to LCD driving circuit instead of VLCD. So if VLCD is supplied externally during partial display mode, Vcc short-circuit to VLCD. High voltage circuit is driven with Vcc in this mode. Vcc voltage must be over 3 V.

Table 9 Partial Display Block

R11	ADC = 1	ADC = 0
H'00	COM1 → COM8	COM8 → COM1
H'01	COM9 → COM16	COM16 → COM9
H'02	COM17 → COM24	COM24 → COM17
H'03	COM25 → COM32	COM32 → COM25
H'04	COM33 → COM40	COM40 → COM33
H'05	COM80 → COM73	COM73 → COM80
H'06	COM72 → COM65	COM65 → COM72
H'07	COM64 → COM57	COM57 → COM64
H'08	COM56 → COM49	COM49 → COM56
H'09	COM48 → COM41	COM41 → COM48

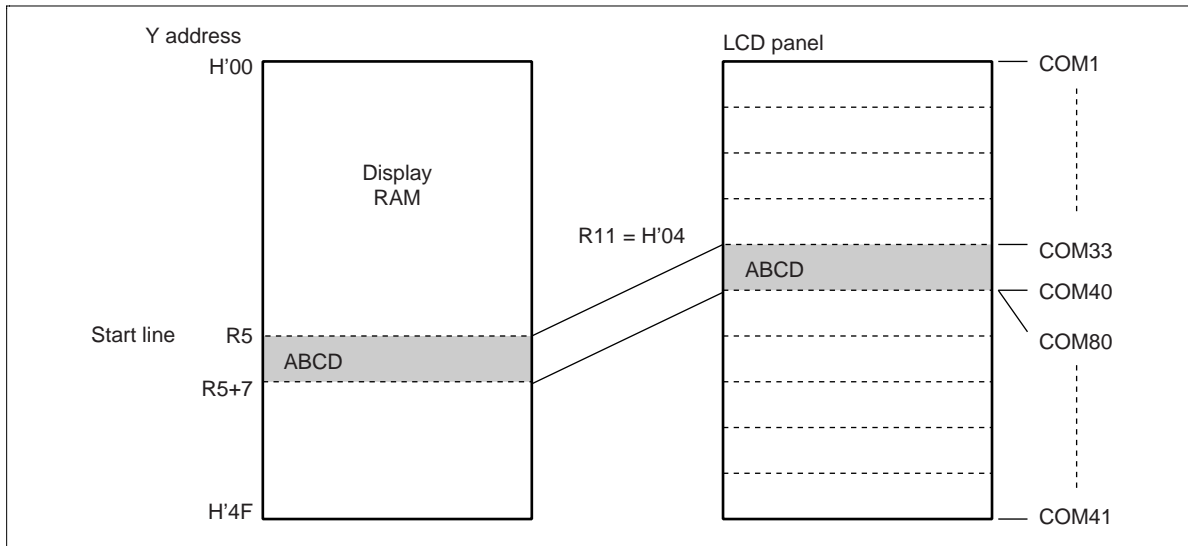

Figure 35 Partial Display

HD66420

Blink Function

The HD66420 can blink a specified area on the dot-matrix display. Blinking is achieved by repeatedly turning on and off the specified area at a frequency of one sixty-fourth the frame frequency. For example, when the frame frequency is 80 Hz, the area is turned on and off every 0.8 seconds.

The area to be blinked can be designated by specifying vertical and horizontal positions of the area. The vertical position or the rasters to be blinked, are specified by the blink start raster register (R6) and blink end raster register (R7).

The horizontal position, or the dots to be blinked in the specified rasters, are specified by the blink registers R8, R9 and R10 in an 8-dot group; each data bit in the blink registers controls its corresponding 8-dots group. The relationship between the registers and blink area is shown in figure 36. Setting the BLK bit to 1 in control register 2 after setting the above registers starts blinking the designated area. Note that since the area to be blinked is designated absolutely with respect to the display RAM, it will move along with a scrolling display (figure 37).

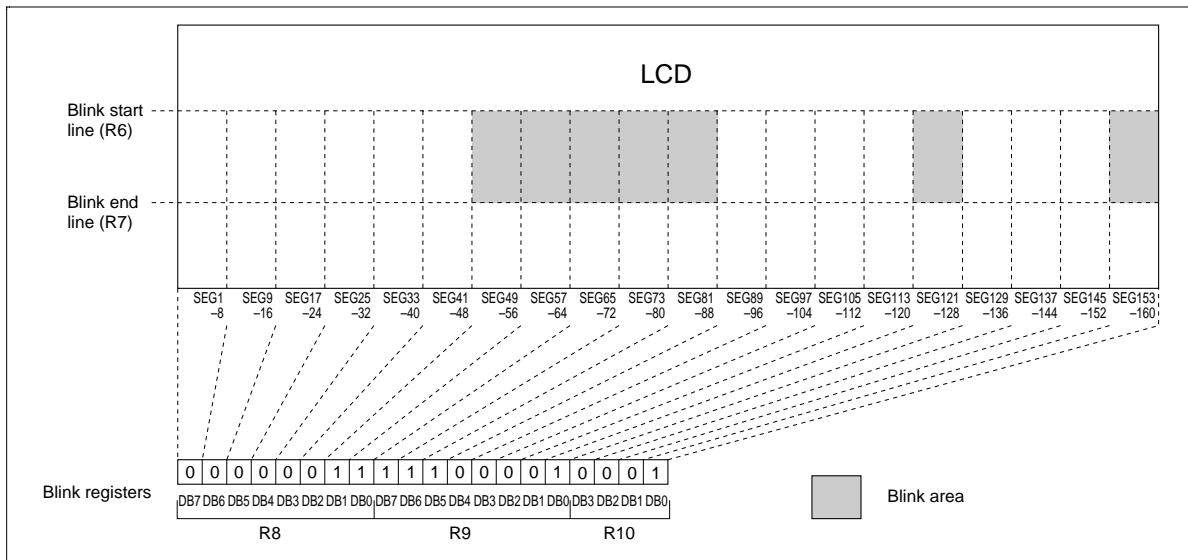

Figure 36 Blink Area Designation by Blink Control Registers

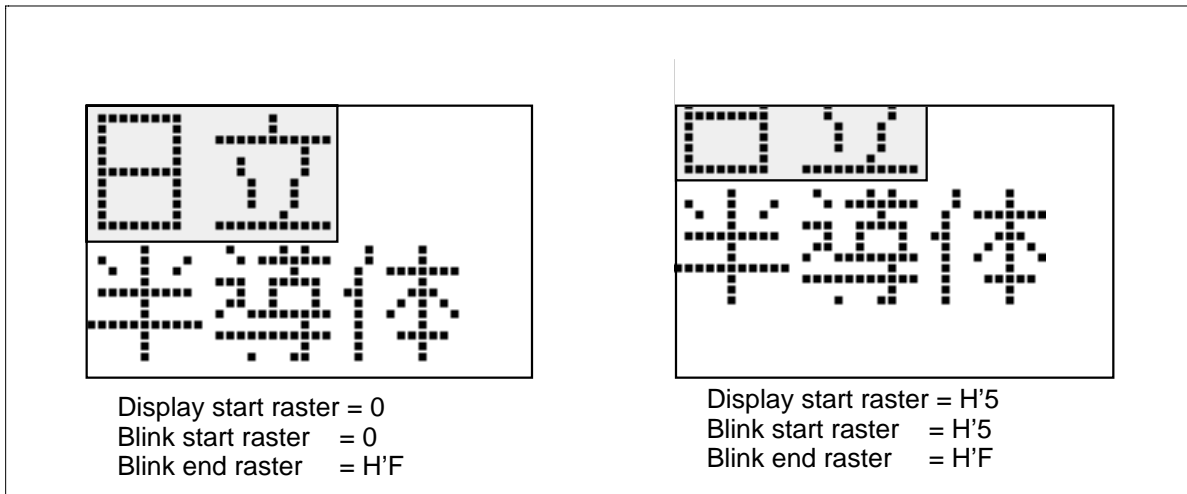

Figure 37 Scrolling Blink Area

HD66420

Power Down Modes

The HD66420 has a standby function providing low power-dissipation, which is initiated by internal register settings. During standby mode, all the HD66420 functions are inactive and data in the display RAM and internal registers except the DISP bit are retained. However, only control registers can be accessed during standby mode. HD66420 has another power down mode: partial display. In this mode only a part of display is active. However, this duty ratio is 1/8 so the external power supply for LCD drive will be inactive. The oscillator does not halt, thus dissipating more power than standby mode. Table 10 lists the LCD driver output pin status during standby mode. Figure 38 shows the procedure for initiating and canceling a standby mode and figure 39 shows the procedure for changing oscillator. Note that these procedure must be strictly followed to protect data in the display RAM.

Table 10 Output Pin Status during Power Down modes

Signal Name	STBY	Status
COM1–COM80	1	Output VLCD (display off)
	0	Output common signals (display on)
SEG1–SEG160	1	Output VLCD (display off)
	0	Output segment signals (display on)

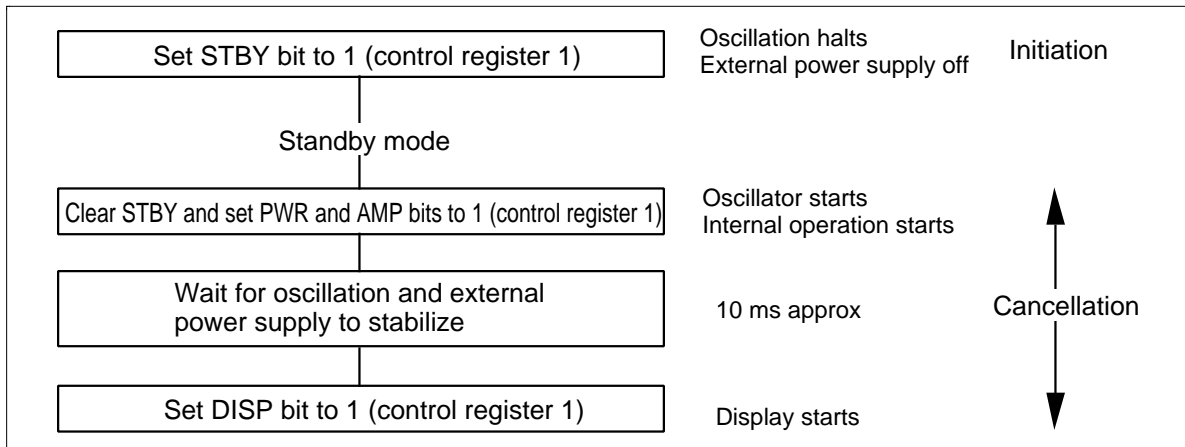

Figure 38 Procedure for Initiation and Canceling a Standby Mode

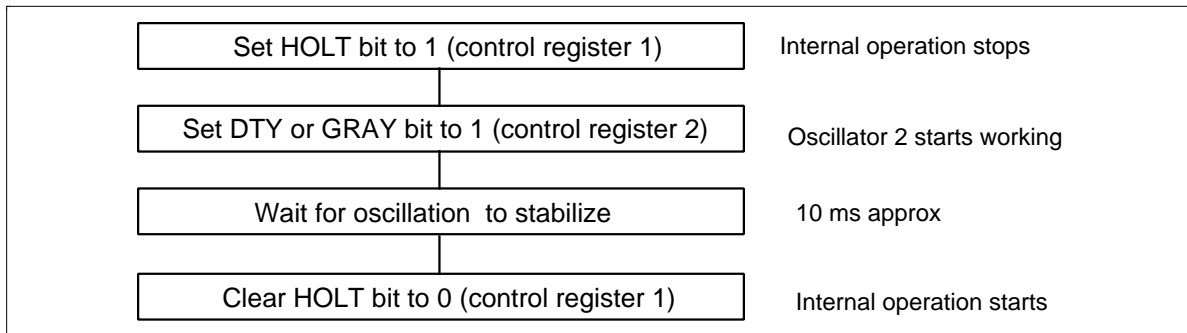

Figure 39 Procedure for Changing Oscillator

Power On/Off Procedure

Figure 40 shows the procedure for turning the power supply on and off. This procedure must be strictly followed to prevent incorrect display because the HD66420 incorporates a power supply circuit.

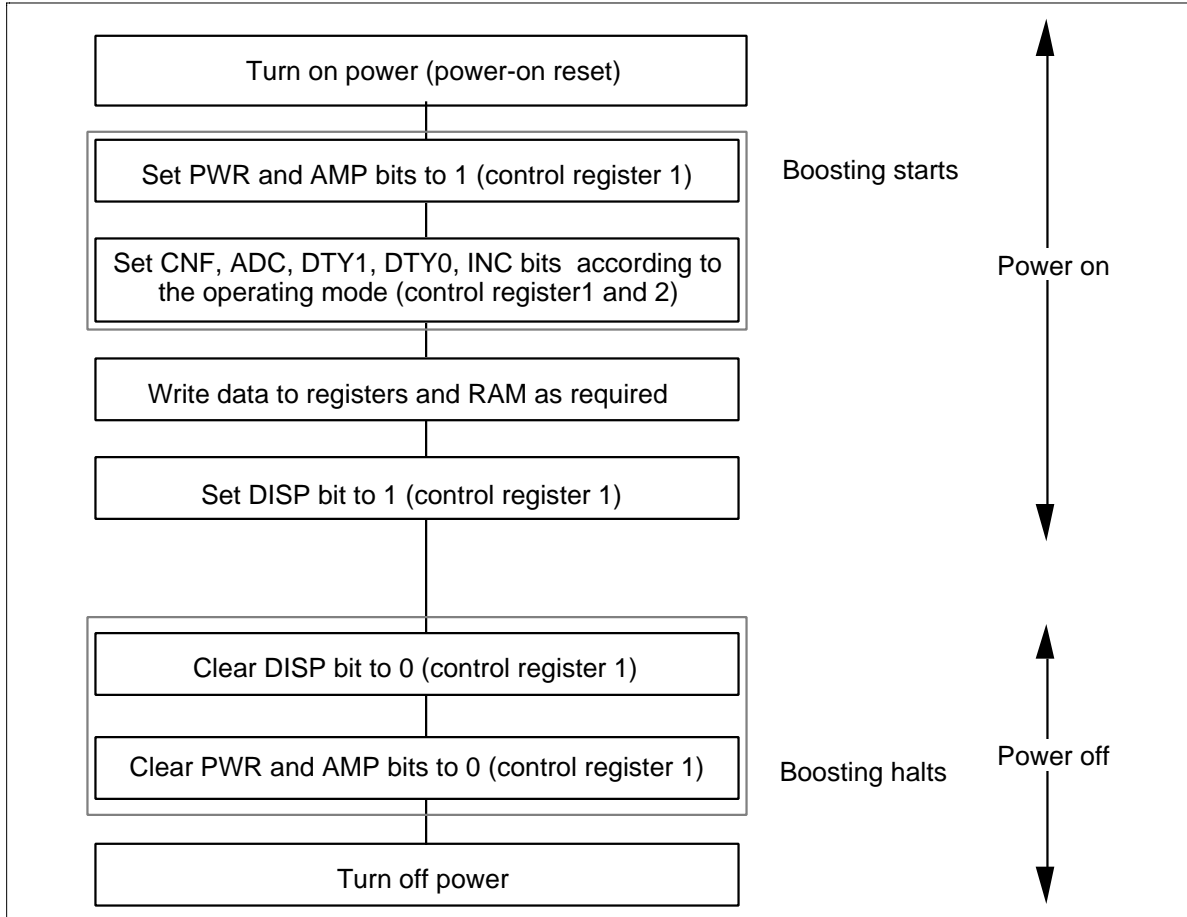

Figure 40 Procedure for Turning Power Supply On/Off

Oscillator

The HD66420 incorporates two sets of R-C oscillator for two display modes: OSC-OSC1 oscillator is used for 32-levels gray scale display mode and OSC-OSC2 oscillator for 4-levels gray scale display mode and partial display mode. If the internal oscillator is not used, an appropriate clock signal must be externally input through the OSC pin. In this case, the OSC1 and OSC2 pins must be left unconnected. Oscillation resistor must be placed near LSI, because if capacitance exists between OSC and OSC1 oscillator may not work properly. Figure 41 shows oscillator connections.

Changing Oscillator

Two oscillators are alternated automatically depending on modes. The resistor between OSC and OSC1 is used during 32-levels grayscale mode and the resistor between OSC and OSC2 is used during 4-levels grayscale mode and partial display mode. An external clock must be input from OSC terminal at any mode.

Clock and Frame Frequency

The HD66420 generates the frame frequency by dividing the input clock. Clock frequency is determined with following equation:

$$f_{osc} = N * (\text{Duty ratio}) * (\text{Frame frequency})$$

N: 31 for 32-level gray scale display mode and partial display mode

3 for 4-level gray scale display mode and partial display mode

The frame frequency is usually 70 to 90 Hz; when the frame frequency is 70 Hz, for example, the input clock frequency will be 180 kHz for 32-level gray scale display mode, and 17kHz for 4-level gray scale and partial display modes.

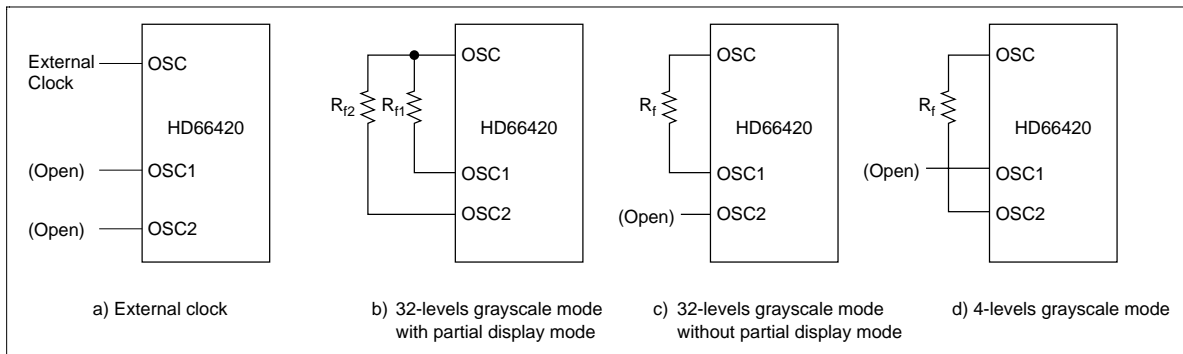

Figure 41 Oscillator Connections

LCD Driving Alternating Cycle

AC voltage needs to be applied to liquid crystals to prevent deterioration due to DC voltage. This alternated cycle is determined by setting Alternating cycle register (R16); 7, 11, 13lines or flame.

HD66420

Table 11 LCD alternative drive cycle

CM1	CM0	Alternative Cycle
0	0	Frame
0	0	7 lines
0	0	11 lines
0	0	13 lines

Power Supply Circuits

HD66420 has following circuits for power supply circuit: operational amplifiers, resistive dividers, bias control circuit and contrast control circuit. LCD driving voltage, VLCD, must be supplied externally.

LCD Drive Voltage Power Supply Levels: To drive the LCD, a 6-level power supply is necessary. These levels are generated internally or supplied from outside. When an internal voltage levels generator is chosen, external capacitors are needed to stabilize these levels. AS the HD66420 incorporates operational amplifiers to these levels, this circuit gives better quality of display with less power consumption. This divided ratio is programmable.

Bias current of internal operational amplifier is determined with a resistor which is inserted between IREFM and GND and IREFP is connected to V_{cc}. This resistor value is between 1M Ω and 5M Ω . Larger resistor value make less power consumption at internal operational amplifier. However, too large value loose operational margin of amplifiers.

Keep following relationship among voltage levels;

$$V_{cc} \geq IREFMP > IREFM \geq GND$$

$$VLCD > V_{cc} > GREF \geq GND$$

$$VLCD \geq V10 \geq V20 \geq V30 \geq V40 \geq V50 \geq GREF$$

$$VLCD - V_{cc} \geq 1.0V$$

$$IREFP - IREFM \geq 1.0V$$

$$V_{cc} - GREF \geq 1.0V$$

Contrast Control: Internal contrast control circuit can change the output voltage level of VLCD by setting data to contrast control register, R16. VLCD adjustable range are showed below;

- 1/6 bias
 $0.75 * (VLCD - GND) \leq VLCD \leq 0.99 * (VLCD - GND)$
- 1/9 bias
 $0.82 * (VLCD - GND) \leq VLCD \leq 0.993 * (VLCD - GND)$

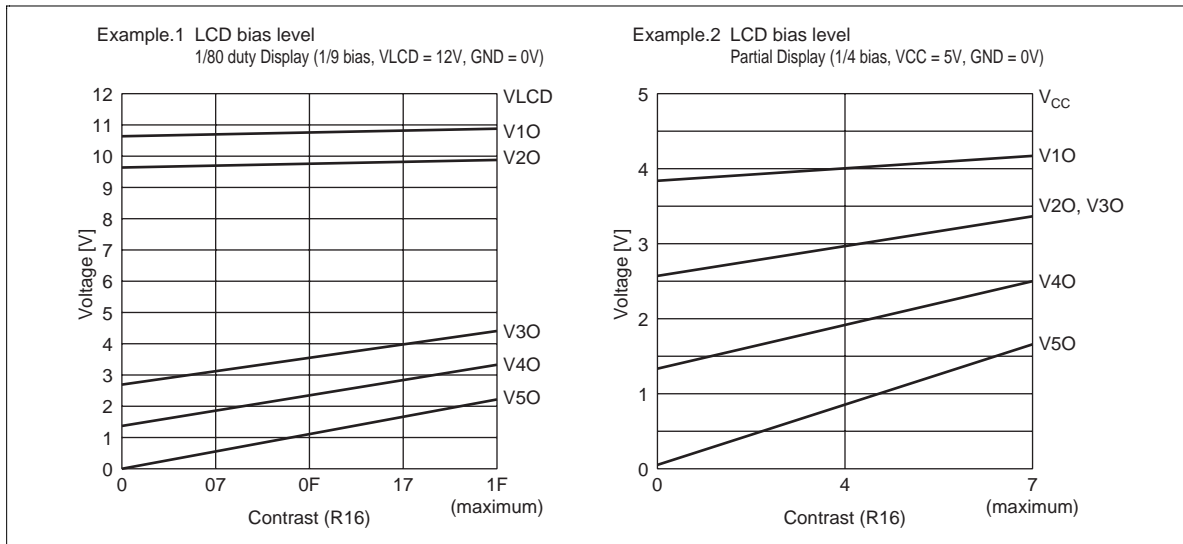

- Partial display

$$0.82 * (V_{CC}-GND) \leq V_{CC} \leq 0.997 (V_{CC}-GND)$$

Partial display function uses 1/4 bias ratio from V_{CC} to GND. Eight levels of contrast can be selected with data bit 2 to 0 of R16. These bits are used as the contrast control bits of 32-levels and 4-levels grayscale display mode. Reset these bits when changing modes.

LCD drive levels bias ratio: LCD driving levels bias ratio can be selected from 1/6, 1/7, 1/8 or 1/9.

Power Supply: The HD66420 needs the external power supply for LCD driving circuit. If this power circuit has on/off control, the HD66420 controls the external power supply circuit with DCON which is controlled by PWR bit.

External Power Supply Circuit: When the internal operational amplifier cannot fully drive the LCD panel used, V10 to V50 voltages can be supplied from external power supply circuit. Here, the AMP bit must be set to 0 to turn off the internal power supply circuit. If this case, IREFP is connected to V_{CC} , GREF to GND and IREFM is left open.

HD66420

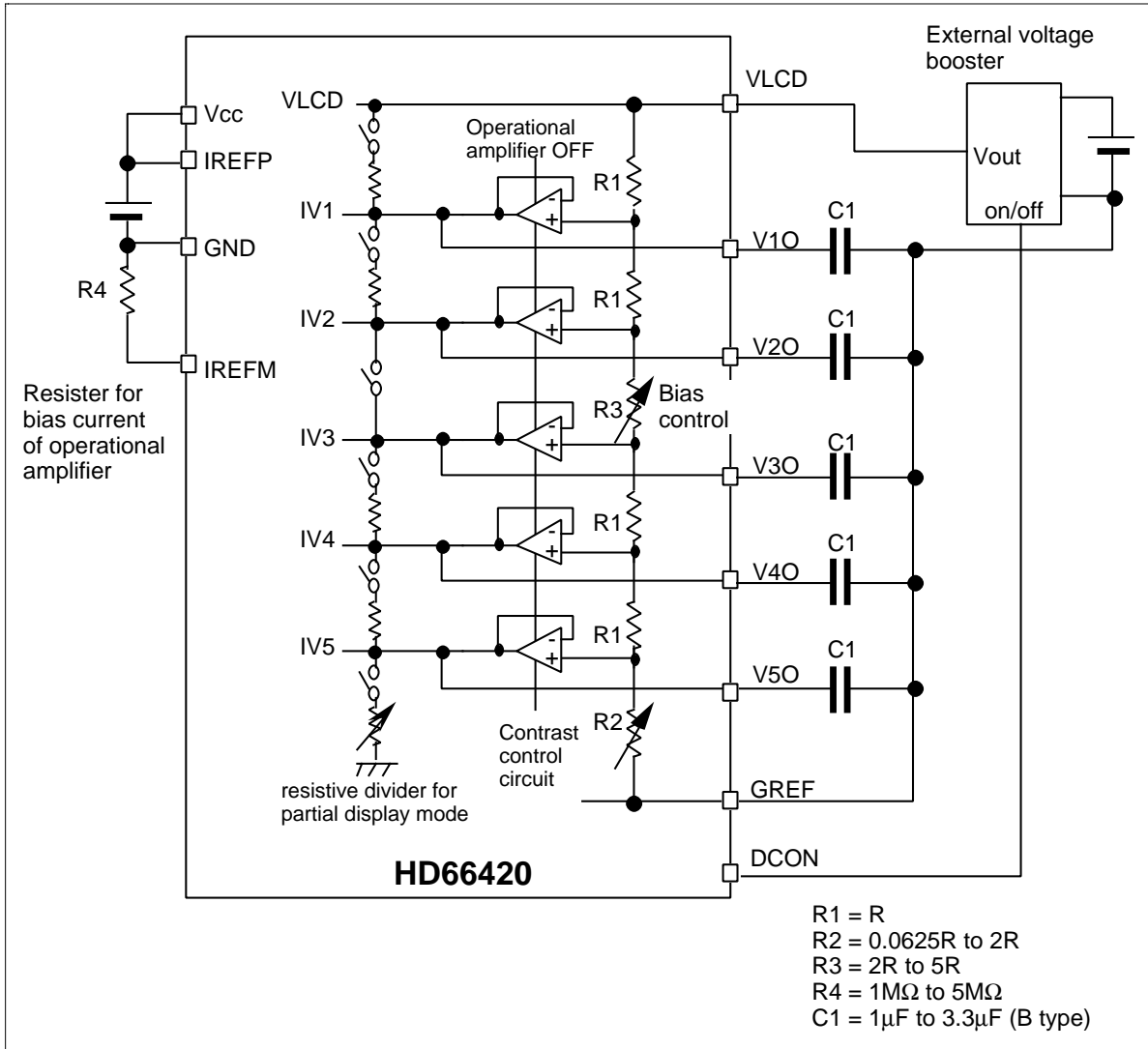

Figure 42 Power Supply Circuit

Reset

The low $\overline{\text{RES}}$ signal initializes the HD66420, clearing all the bits in the internal registers. During reset, the internal registers cannot be accessed.

The electrical characteristics of low level width of $\overline{\text{RES}}$ must be kept to make sure the operation of HD66420.

Initial Setting of Internal Registers: All the internal register bits are cleared to 0. Details are listed below.

- Clear all register data bit(H'00) from R0 to R11 and R16
- Set default value from R12 to R15 data bits
- Normal operation
- Oscillator is active; OSC-OSC1 is used
- Display is off
- Y address of display RAM is incremented
- 1/80 duty cycle
- X and Y addresses are 0
- Data in address H'0 is output from the SEG1 pin
- Blink function is inactive
- Operational amplifier is disabled
- LCD alternative drive cycle is frame

Initial Setting of Pins:

Bus interface pins

During reset, the bus interface pins do not accept signals to access internal registers; data is undefined when read.

LCD driver output pins

During reset, all the LCD driver output pins (SEG1 to SEG161, COM1 to COM80) output Vcc-level voltage, regardless of data value in the display RAM, turning off the LCD. Here, the output voltage is not alternated. Note that the same voltage (VLCD) is applied to both column and row output pins to prevent liquid crystals from degrading.

HD66420

Precautionary Notes When Using the HD66420

Flickering may be appeared on display with HD66420 while HD66420's internal RAM is being read or written from CPU.

Flickering

The wrong data is transferred to LCD driving circuit when the rising edge of RD or WR occur slightly before the falling edge of LSI internal reading signal, between 0 and 200 ns. This action causes that the unexpected line may be appeared on the display at random for a short while. The timing which flickering may occur is shown in figure 43.

The flickering appear while CPU is reading or writing data to HD66420's internal RAM. The flickering disappear when the access from CPU stops and stored data in the RAM will not be destroyed.

How to Avoid Flickering

- (1) The external circuit must be needed to avoid flickering if the software needs to rewrite data frequently like moving picture. The busy signal must be generated externally and the software must check this status before reading or writing or use this busy signal as a wait signal for CPU. This circuit and timing are shown in figure 44 and figure 45. This circuit is one example for your reference, you must design this timing according to your system.
- (2) It is possible that the external circuit is not needed if the data does not needed to be rewritten frequently. The flickering may occur occasionally, then please evaluate carefully on your system in this case.
- (3) The same countermeasures as (1) is needed for reading from CPU.

These countermeasures must be designed and evaluated carefully on your system.

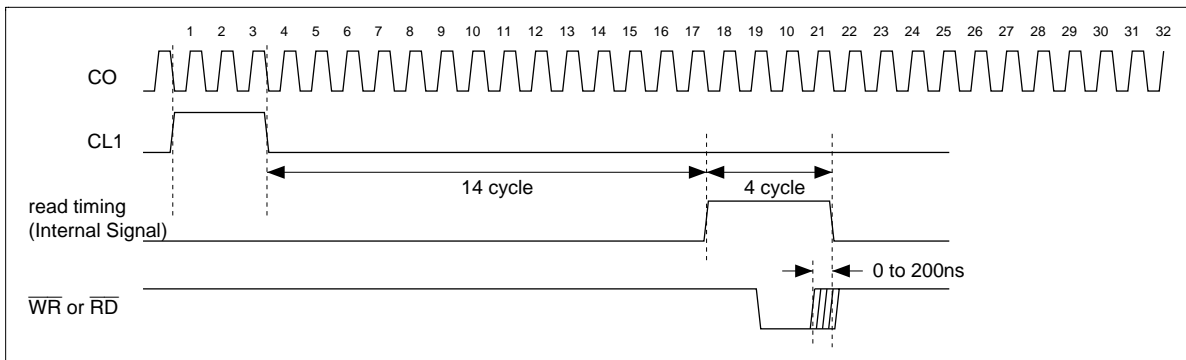

Figure 43 The timing of Wrong Data Transfer

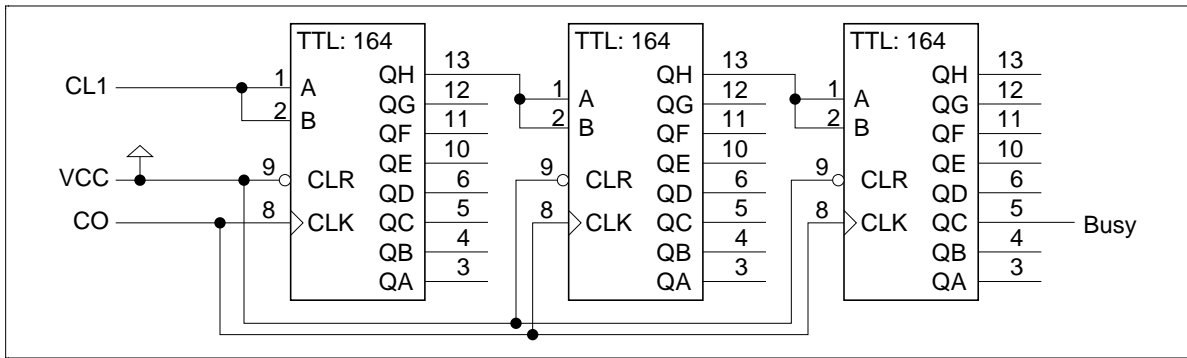

Figure 44 Example of external circuits

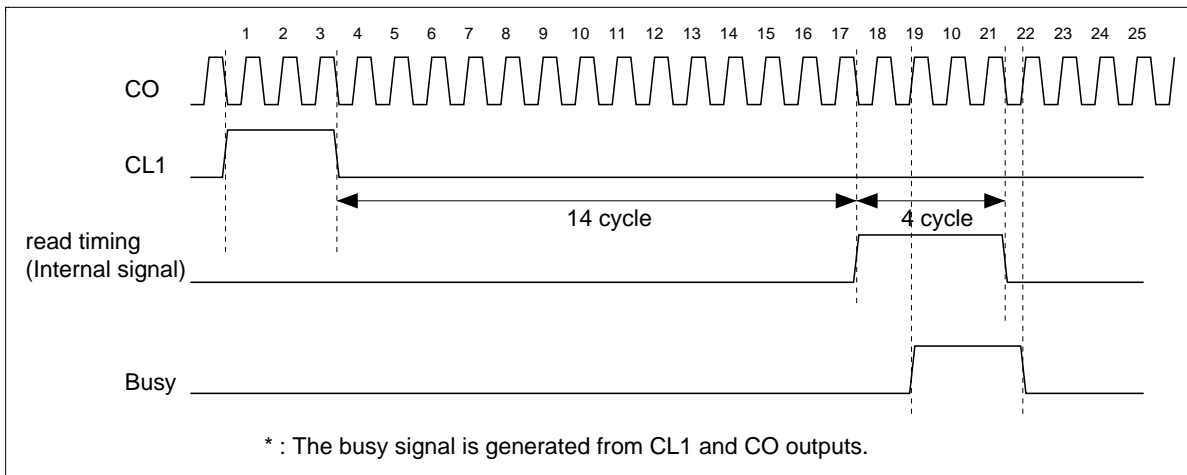

Figure 45 The Timing Chart of External Circuit

HD66420

Example of external circuit

The example of external circuit of HD66420 is showed in Figure 46. This circuit is just the example and not guaranteed to work at any condition. Please example these circuit before you see.

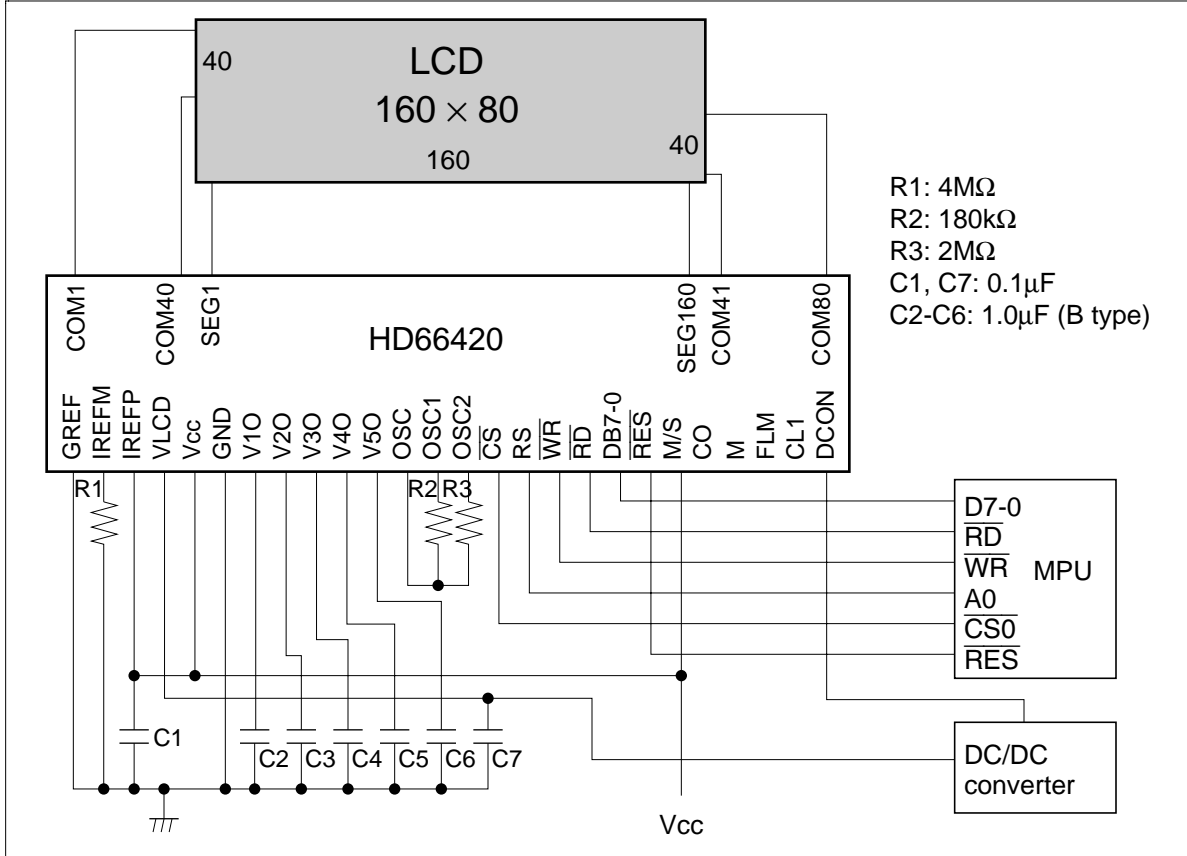

Figure 46 Example of external circuit

Absolute Maximum Ratings

Item		Symbol	Ratings	Unit	Notes
Power Supply voltage	Logic circuit	V_{CC}	-0.3 to +7.0	V	1
	LCD drive circuit	VLCD	-0.3 to +17.0	V	
Input voltage 1		VT1	-0.3 to $V_{CC} + 0.3$	V	1, 2
Input voltage 2		VT2	0.3 to VLCD + 0.3	V	1, 3
Operation temperature		T_{opr}	-40 to +85	°C	
Storage temperature		T_{stg}	-55 to +110	°C	

Notes: 1. Measured relative to GND

2. Applies to pins M/\bar{S} , OSC, OSC1, OSC2, DB7 to DB0, \bar{RD} , \bar{WR} , \bar{CS} , RS, \bar{RES} , CL1, M, FLM

3. Applies to pins V10, V20, V30, V40 and V50

4. If the LSI is used beyond its absolute maximum rating, it may be permanently damaged.

It should always be used within the limits of its electrical characteristics to prevent malfunction or unreliability.

HD66420

Electrical Characteristics

DC Characteristics ($V_{CC} = 2.2$ to $5.5V$, $GND = 0V$, $V_{LCD} = 6$ to $15V$, $T_a = -40$ to $+85^\circ C$)^{*9}

Item	Symbol	Terminals	Min	Typ	Max	Unit	Test Condition	Notes
I/O leakage current	I_{IOL}		-1	—	1	μA	$V_{in} = V_{CC}$ to GND	1
V-pins leakage current	I_{VL}		-10	—	10	μA	$V_{in} = GND$ to V_{LCD}	2
Driver on resistance	R_{on}	SEG1 to SEG160 COM1 to COM80			20	$k\Omega$	$I_{ON} = 100 \mu A$ $V_{LCD} = 6 V$	3
Input high voltage	V_{IH1}		$0.8 \times V_{CC}$	—	V_{CC}	V		1
Input low voltage	V_{IL1}		0	—	$0.2 \times V_{CC}$	V		1
Output high voltage	V_{OH}	DB7 to DB0	$0.8 \times V_{CC}$	—	V_{CC}	V	$I_{OH} = -50 \mu A$	4
Output low voltage	V_{OL}	DB7 to DB0	0	—	$0.2 \times V_{CC}$	V	$I_{OL} = 50 \mu A$	4
Current consumption during display	I_{disp}	V_{CC}	—	55	80	μA	$V_{CC} = 3.0 V$ $R_f = 240 k\Omega$	5, 6
Current consumption during standby	I_{stb}	V_{CC}	—	1	5	μA		5, 7
Current consumption LCD drive part	I_{lcd}	V_{LCD}	—	30	50	μA		5, 8

- Note:
- Applies to pins: M/S, \overline{CS} , \overline{RS} , \overline{WR} , \overline{RD} , \overline{RES} , OSC, DB7 to DB0, CL1, M and FLM
 - Applies to pins: V0O, V1O, V2O, V3O, V4O and V5O
 - Indicates the resistance between one pin from SEG1 to SEG160 and another pin from V1O to V5O
V1O and V2O should be near V_{LCD} level, and V3O to V5O should be near GND level. All voltage must be within ΔV . ΔV is the range within which R_{on} is stable. V1 to V4 levels should keep following condition: $V_{LCD} \geq V1O \geq V2O \geq V3O \geq V4O \geq V5O \geq GND$
 - Applies to pins: DB7-DB0, CO, CL1, M and FLM
 - Input and output current are excluded. When a CMOS input is floating, excess current flows from power supply to the input circuit. To avoid this, V_{IH} and V_{IL} must be held to V_{CC} and GND levels, respectively.
The current which flows at LCD are excluded.
Where the unmolded side of LSI is exposed to light, excess current flows. Use under sealed condition.
 - Specified under following conditions:
Internal oscillator is used; $R_f = 240k\Omega$
32-levels gray scale mode; GRAY = 0, $V_{CC} = 3.0V$
Checker board is displayed
No access from MPU
 - Measured during stand-by mode.
 $V_{CC} = 3.0V$
 - Specified under following conditions:
Internal power supply circuit is used.

Resistor value is 5MΩ which is connected between IREFM and GND

$V_{CC} = 3.0V$, $V_{LCD} = 12V$, $IREFP = V_{CC}$, $GREF = GND$

9. Specified at +85°C for die products.

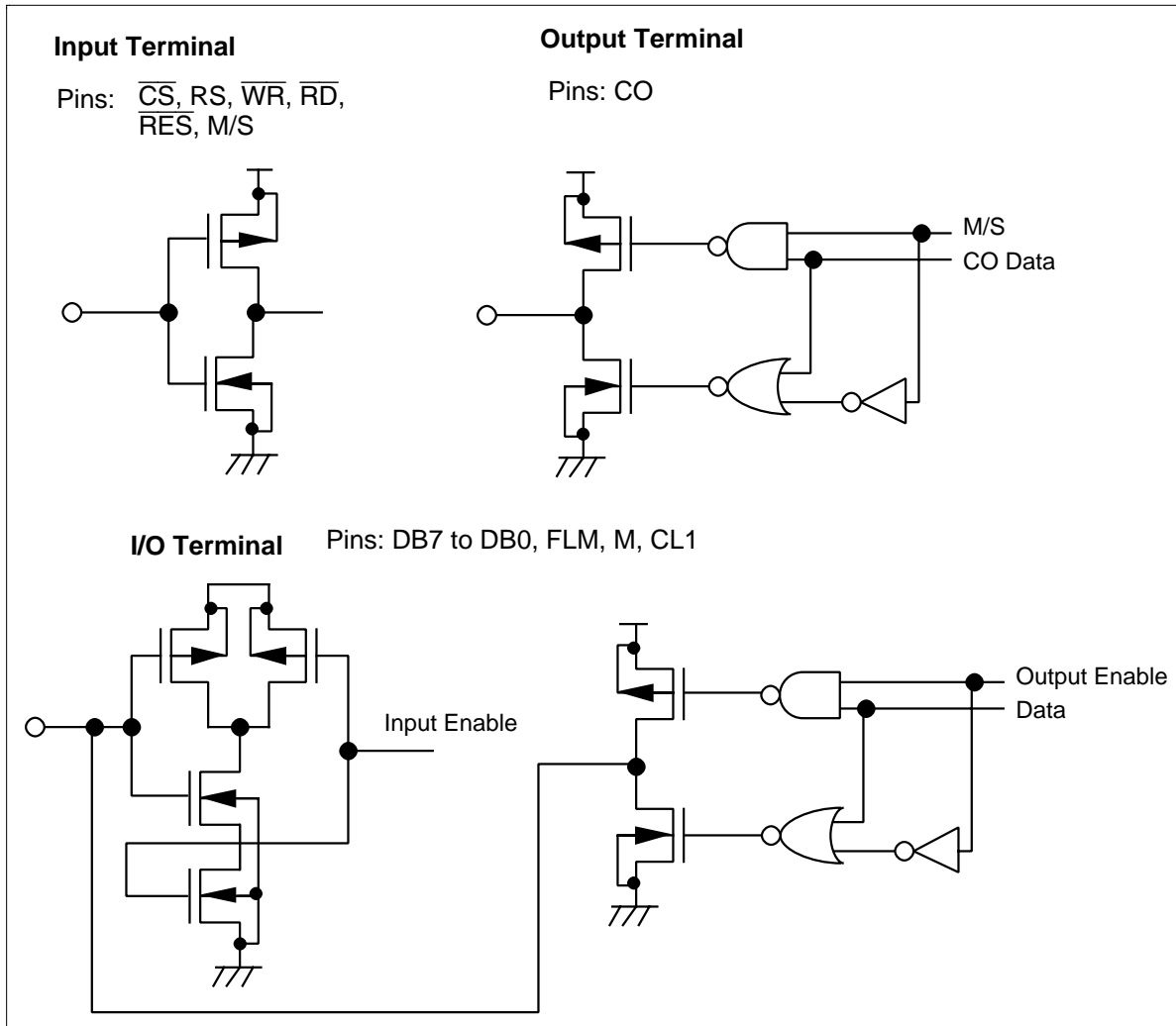

Figure 47 Terminal Configuration

HD66420

AC Characteristics ($V_{CC} = 2.2V$ to $5.5V$, $GND = 0V$, $T_a = -40$ to $+85^\circ C$)*1

Clock Characteristics

Item	Symbol	Min	Typ	Max	Unit	Notes
Oscillation frequency	f_{OSC}	130	180	230	kHz	$R_f = 240\text{ k}\Omega$, $V_{CC} = 3.0\text{ V}$
External clock frequency	f_{CP}	50	—	300	kHz	
External clock duty cycle	Duty	45	50	55	%	
External clock fall time	t_f	—	—	0.2	μs	
External clock rise time	t_r	—	—	0.2	μs	

Reset Timing

Item	Symbol	Min	Typ	Max	Unit	Notes
RES low-level width	t_{RES}	1	—	—	ms	

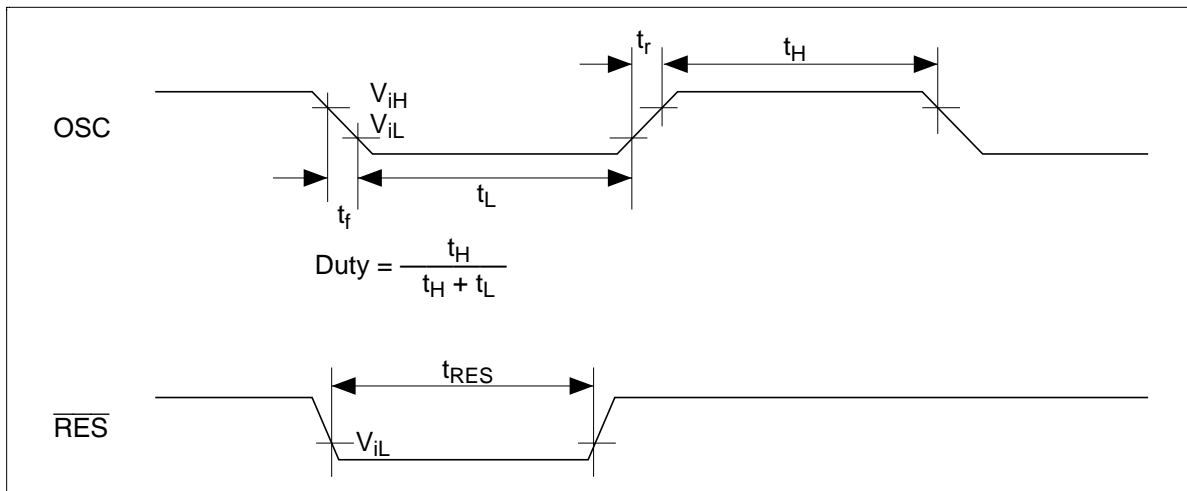

Figure 48 OSC and \overline{RES} Timing

MPU Interface

Item	Symbol	Min	Typ	Max	Unit	Notes
RD low-level width	t_{WRDL}	250	—	T-450	ns	$V_{CC} = 2.2\text{ V to }3.0\text{ V}^{*2}$
		190	—	T-450	kHz	$V_{CC} = 3.0\text{ V to }5.5\text{ V}^{*2}$
RD high-level width	t_{WRDH}	450	—	—	ns	
WR low-level width	t_{WWRL}	250	—	T-450	ns	$V_{CC} = 2.2\text{ V to }3.0\text{ V}^{*2}$
		190	—	T-450	ns	$V_{CC} = 3.0\text{ V to }5.5\text{ V}^{*2}$
WR high-level width	t_{WWRH}	450	—	—	ns	
Address setup time	t_{AS}	20	—	—	ns	
Address hold time	t_{AH}	10	—	—	ns	
Data delay time	t_{DDR}	—	—	180	ns	$V_{CC} = 2.2\text{ V to }3.0\text{ V}$
		—	—	150	ns	$V_{CC} = 3.0\text{ V to }5.5\text{ V}$
Data output hold time	t_{DHR}	10	—	—	ns	
Data setup time	t_{DSW}	150	—	—	ns	$V_{CC} = 2.2\text{ V to }3.0\text{ V}$
		100	—	—	μs	$V_{CC} = 3.0\text{ V to }5.5\text{ V}$
Data hold time	t_{DHW}	10	—	—	ns	

Note : 1. Specified at +85°C for die products.
 2. $T=4 \times t_{cyc}$ for 32-levels gray scale mode
 $T=t_{cyc}$ for 4-levels gray scale and partial display mode.
 $t_{cyc}=1/f_{osc}$ or $1/f_{cp}$

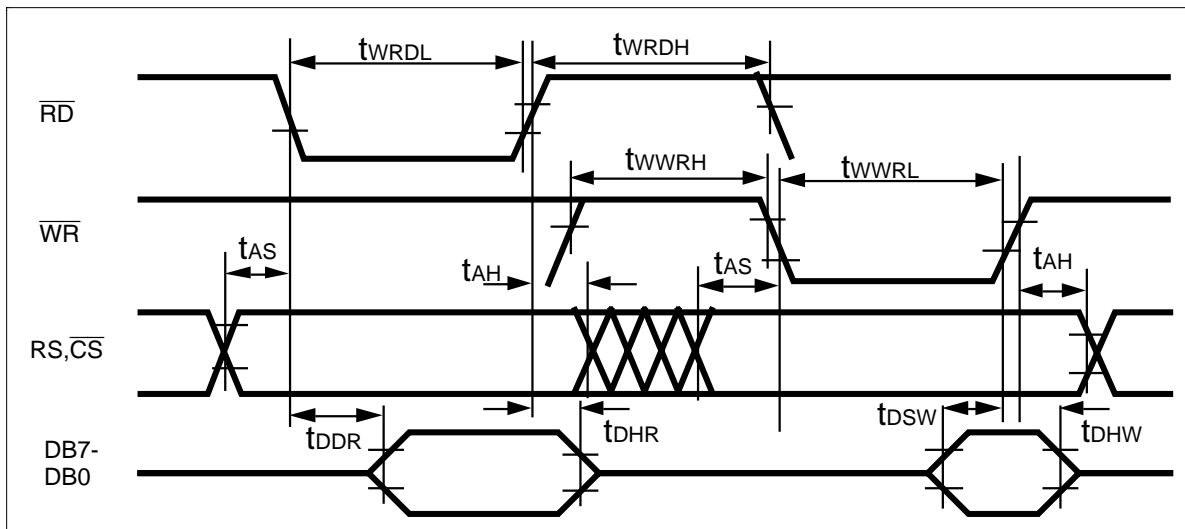
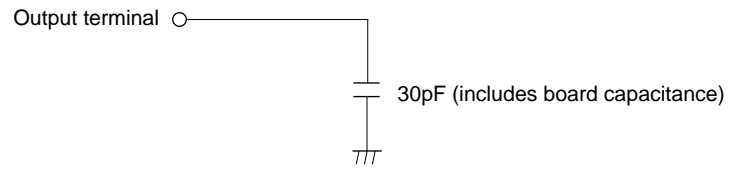

Figure 49 MPU Interface

HD66420

Note: the following load circuit is connected for specification.
VOH and VOL of the timing specification is 1/2 VCC level.



<<Reference Data>>

Note: All data is measured with Standard sample at +25°C

1. Frequency of Oscillator

1.1. 32-levels gray scale mode, usign OSC-OSC1 oscillator

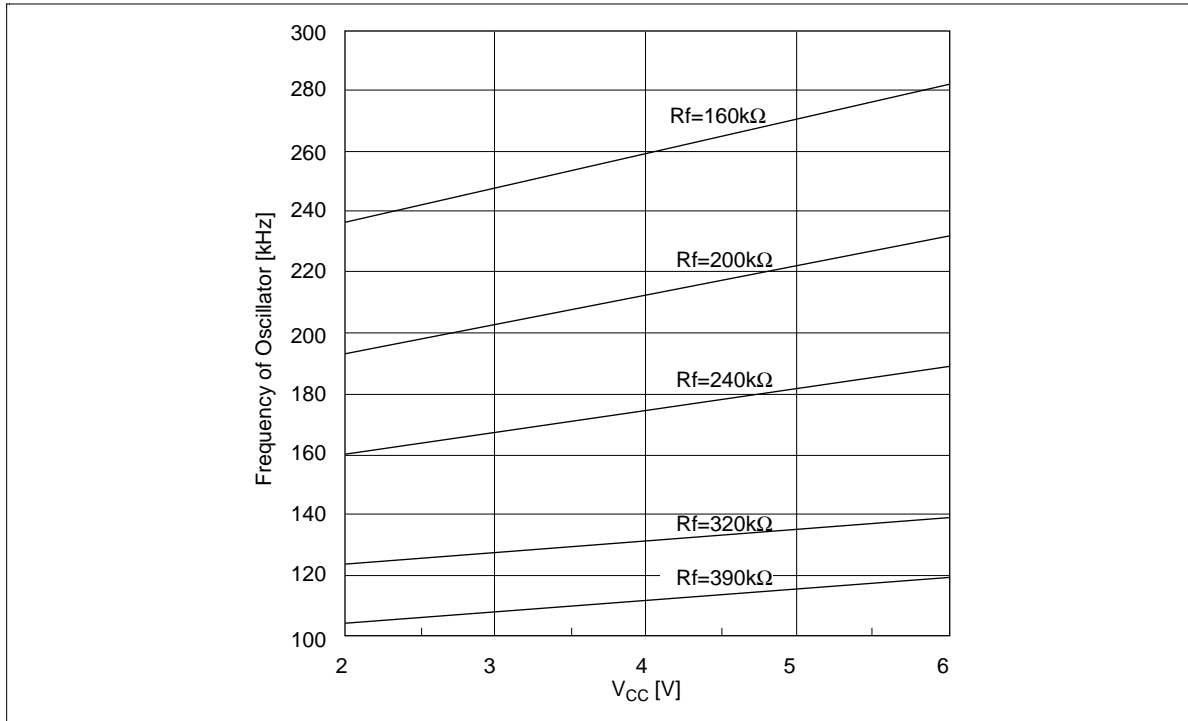
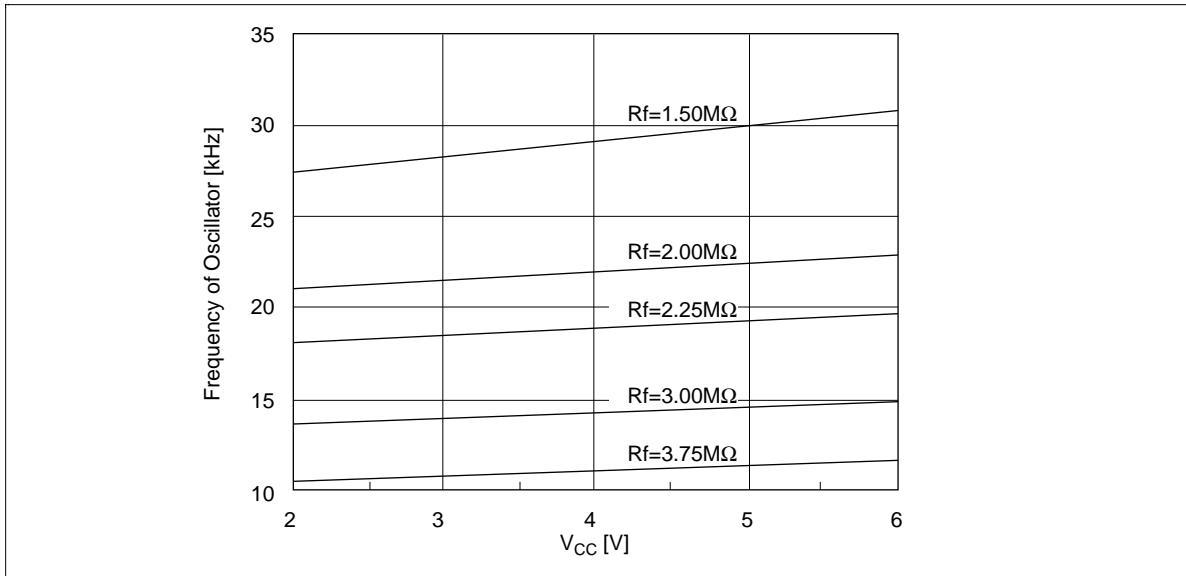
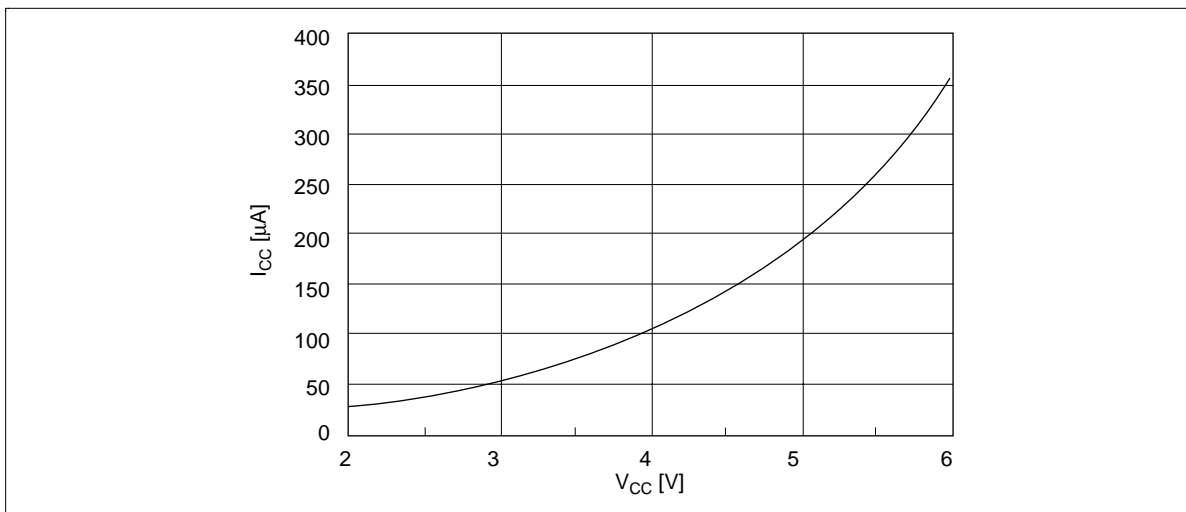

Figure 50 OSC-OSC1 Oscillator Frequency

1.2. 4-levels gray scale and partial display mode, usign OSC-OSC2 oscillator

**Figure 51 OSC-OSC2 Oscillator Frequency**

2. Power consumption

Conditions: R_f = 240 kΩ, Opamp on, 1/80 Duty, Checker pattern displayed, no load2.1. 32-levels gray scale mode, V_{cc} vs. I_{cc} during display**Figure 52 I_{cc} (VLCD = 12 V)**

2.2. 32-levels gray scale mode, VLCD vs. ILCD during display

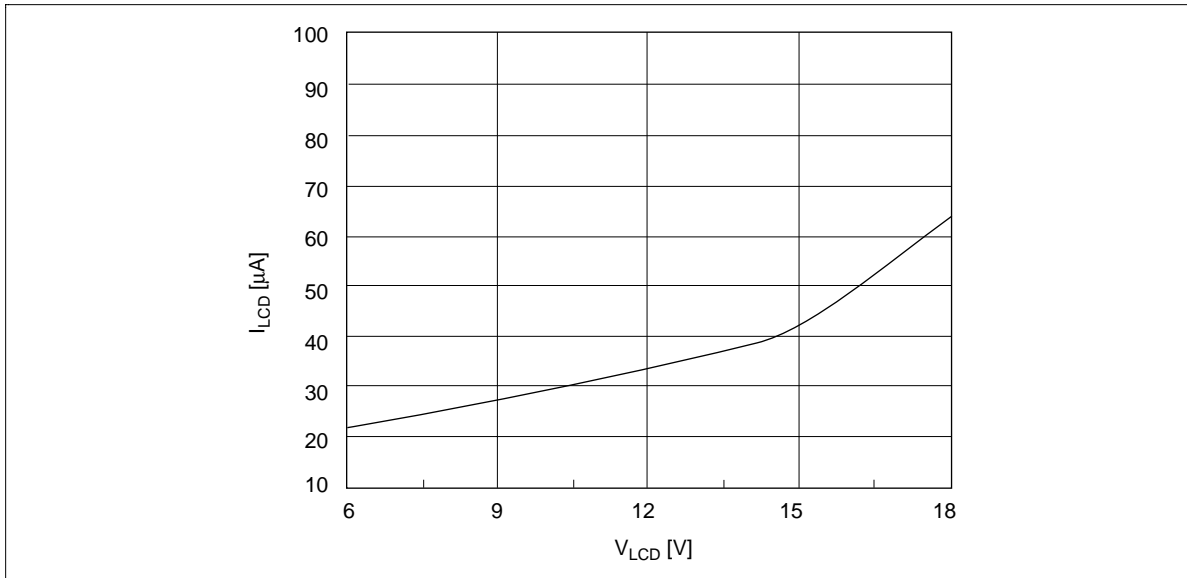
**Figure 53 ILCD (VCC = 3 V)**

HD66420

2.3. Power consumption during MPU access

MPU (H8/536S) wrote checker pattern to HD66420, and alternately write 0 and 1 to same address RAM continuously.

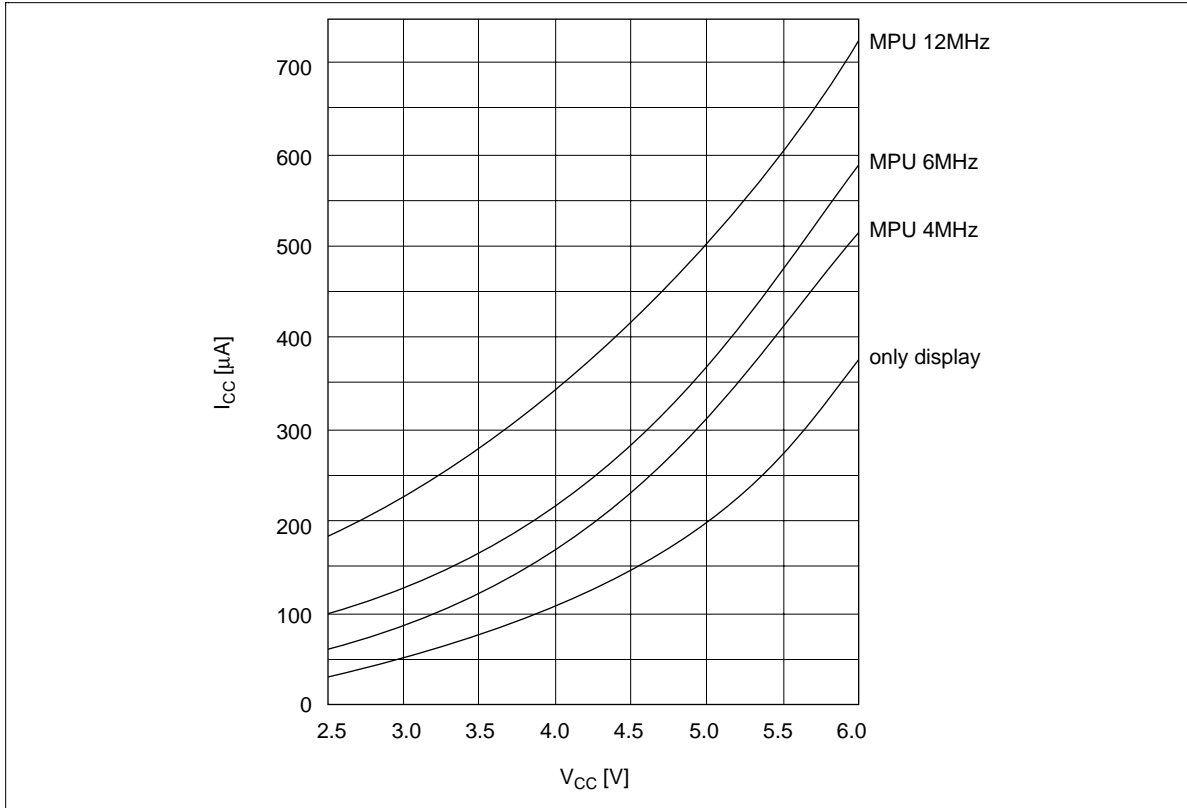

Figure 54 V_{CC} vs. I_{CC} (VLCD = 12 V, MPU accessing)

2.4. 4-levels gray scale mode and partial display mode

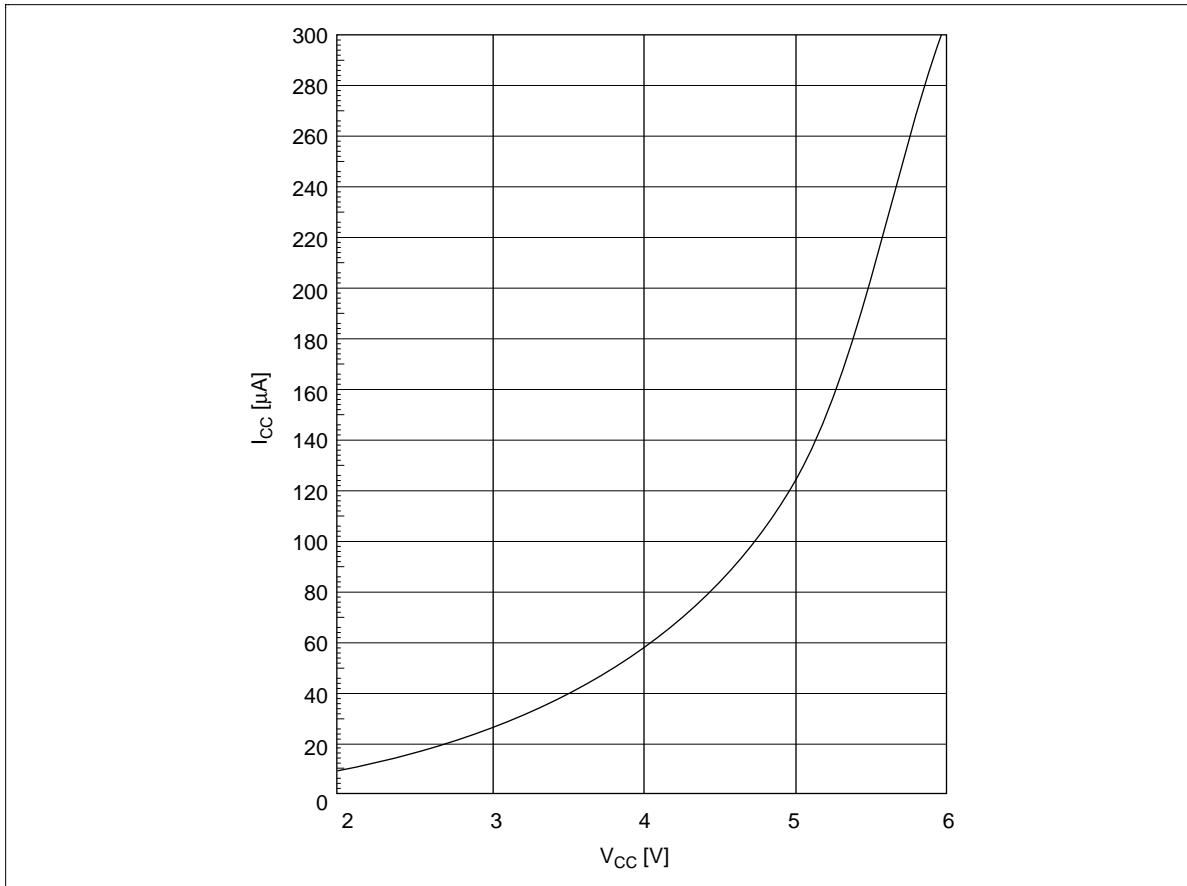

Figure 55 V_{CC} vs. I_{CC} (Partial display mode)

Cautions

1. Hitachi neither warrants nor grants licenses of any rights of Hitachi's or any third party's patent, copyright, trademark, or other intellectual property rights for information contained in this document. Hitachi bears no responsibility for problems that may arise with third party's rights, including intellectual property rights, in connection with use of the information contained in this document.
2. Products and product specifications may be subject to change without notice. Confirm that you have received the latest product standards or specifications before final design, purchase or use.
3. Hitachi makes every attempt to ensure that its products are of high quality and reliability. However, contact Hitachi's sales office before using the product in an application that demands especially high quality and reliability or where its failure or malfunction may directly threaten human life or cause risk of bodily injury, such as aerospace, aeronautics, nuclear power, combustion control, transportation, traffic, safety equipment or medical equipment for life support.
4. Design your application so that the product is used within the ranges guaranteed by Hitachi particularly for maximum rating, operating supply voltage range, heat radiation characteristics, installation conditions and other characteristics. Hitachi bears no responsibility for failure or damage when used beyond the guaranteed ranges. Even within the guaranteed ranges, consider normally foreseeable failure rates or failure modes in semiconductor devices and employ systemic measures such as fail-safes, so that the equipment incorporating Hitachi product does not cause bodily injury, fire or other consequential damage due to operation of the Hitachi product.
5. This product is not designed to be radiation resistant.
6. No one is permitted to reproduce or duplicate, in any form, the whole or part of this document without written approval from Hitachi.
7. Contact Hitachi's sales office for any questions regarding this document or Hitachi semiconductor products.

HITACHI

Hitachi, Ltd.

Semiconductor & Integrated Circuits.
Nippon Bldg., 2-6-2, Ohte-machi, Chiyoda-ku, Tokyo 100-0004, Japan
Tel: Tokyo (03) 3270-2111 Fax: (03) 3270-5109

URL North America : <http://semiconductor.hitachi.com/>
 Europe : <http://www.hitachi-eu.com/hel/ecg>
 Asia (Singapore) : <http://www.has.hitachi.com.sg/grp3/sicd/index.htm>
 Asia (Taiwan) : http://www.hitachi.com.tw/E/Product/SICD_Frame.htm
 Asia (HongKong) : <http://www.hitachi.com.hk/eng/bo/grp3/index.htm>
 Japan : <http://www.hitachi.co.jp/Sicd/index.htm>

For further information write to:

Hitachi Semiconductor
(America) Inc.
179 East Tasman Drive,
San Jose, CA 95134
Tel: <1> (408) 433-1990
Fax: <1> (408) 433-0223

Hitachi Europe GmbH
Electronic components Group
Dornacher Straße 3
D-85622 Feldkirchen, Munich
Germany
Tel: <49> (89) 9 9180-0
Fax: <49> (89) 9 29 30 00

Hitachi Europe Ltd.
Electronic Components Group.
Whitebrook Park
Lower Cookham Road
Maidenhead
Berkshire SL6 8YA, United Kingdom
Tel: <44> (1628) 585000
Fax: <44> (1628) 778322

Hitachi Asia Pte. Ltd.
16 Collyer Quay #20-00
Hitachi Tower
Singapore 049318
Tel: 535-2100
Fax: 535-1533

Hitachi Asia Ltd.
Taipei Branch Office
3F, Hung Kuo Building, No.167,
Tun-Hwa North Road, Taipei (105)
Tel: <886> (2) 2718-3666
Fax: <886> (2) 2718-8180

Hitachi Asia (Hong Kong) Ltd.
Group III (Electronic Components)
7/F., North Tower, World Finance Centre,
Harbour City, Canton Road, Tsim Sha Tsui,
Kowloon, Hong Kong
Tel: <852> (2) 735 9218
Fax: <852> (2) 730 0281
Telex: 40815 HITEC HX

Copyright © Hitachi, Ltd., 1998. All rights reserved. Printed in Japan.