

Ledtech DUAL DIGIT DISPLAY

0.4" DUAL DIGIT DISPLAY Electrical/Optical Characteristics at $T_A=25^\circ\text{C}$ & $I_F=20\text{mA}$

CHIP COLOR	0.4 inch DUAL DIGIT DUPLEX DRIVE		0.4 inch DUAL DIGIT DIRECT DRIVE		λ_p (nm)	V_F (V)	I_V (mcd)	
	COMMON ANODE	COMMON CATHODE	COMMON ANODE	COMMON CATHODE			TYP.	TYP.
GREEN	LD4022-11	LE4022-11	LA4022-11	LC4022-11	572	2.1	3.9	6.5
YELLOW	LD4032-11	LE4032-11	LA4032-11	LC4032-11	589	2.1	3.1	5.2
ORANGE	LD4042-11	LE4042-11	LA4042-11	LC4042-11	630	2.1	4.5	7.4
ORANGE	LD4042R-11	LE4042R-11	LA4042R-11	LC4042R-11	630	2.1	4.5	7.4
RED	LD4072-11-M1	LE4072-11-M1	LA4072-11-M1	LC4072-11-M1	660	1.7	10.4	17.3
RED	LD4052-11	LE4052-11	LA4052-11	LC4052-11	700	2.1	1.1	1.8

LD40X2-11 COMMON ANODE PIN

NO.	FUNCTION
1.	CATHODE D
2.	CATHODE DP
3.	CATHODE E
4.	CATHODE C
5.	COMMON ANODE (DIGIT 2)
6.	CATHODE B
7.	CATHODE A
8.	CATHODE F
9.	CATHODE G
10.	COMMON ANODE (DIGIT 1)

LE40X2-11 COMMON CATHODE PIN

NO.	FUNCTION
1.	ANODE D
2.	ANODE DP
3.	ANODE E
4.	ANODE C
5.	COMMON CATHODE (DIGIT 2)
6.	ANODE B
7.	ANODE A
8.	ANODE F
9.	ANODE G
10.	COMMON CATHODE (DIGIT 1)

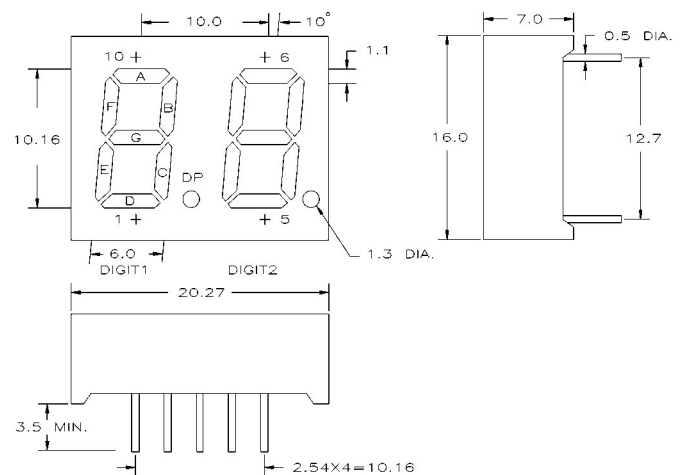

LA40X2-11 COMMON ANODE PIN

NO.	FUNCTION
1.	CATHODE C (DIGIT 1)
2.	CATHODE E (DIGIT 1)
3.	CATHODE D (DIGIT 1)
4.	COMMON ANODE (DIGIT 1)
5.	COMMON ANODE (DIGIT 2)
6.	CATHODE D (DIGIT 2)
7.	CATHODE E (DIGIT 2)
8.	CATHODE C (DIGIT 2)
9.	CATHODE G (DIGIT 2)
10.	CATHODE A (DIGIT 2)
11.	CATHODE F (DIGIT 2)
12.	CATHODE B (DIGIT 2)
13.	CATHODE B (DIGIT 1)
14.	CATHODE F (DIGIT 1)
15.	CATHODE A (DIGIT 1)
16.	CATHODE G (DIGIT 1)

LC40X2-11 COMMON CATHODE PIN

NO.	FUNCTION
1.	ANODE C (DIGIT 1)
2.	ANODE E (DIGIT 1)
3.	ANODE D (DIGIT 1)
4.	COMMON CATHODE (DIGIT 1)
5.	COMMON CATHODE (DIGIT 2)
6.	ANODE D (DIGIT 2)
7.	ANODE E (DIGIT 2)
8.	ANODE C (DIGIT 2)
9.	ANODE G (DIGIT 2)
10.	ANODE A (DIGIT 2)
11.	ANODE F (DIGIT 2)
12.	ANODE B (DIGIT 2)
13.	ANODE B (DIGIT 1)
14.	ANODE F (DIGIT 1)
15.	ANODE A (DIGIT 1)
16.	ANODE G (DIGIT 1)

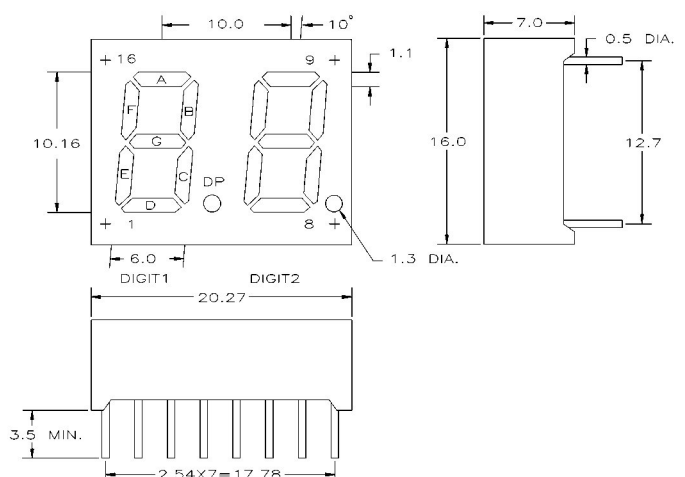

NOTES : 1.ALL DIMENSIONS ARE IN mm, TOLERANCE IS $\pm 0.25\text{mm}$ (0.01") UNLESS OTHERWISE NOTED.
2.THE SLOPE ANGLE OF ANY PIN MAY BE $\pm 5^\circ$ MAX.