

24 × 24 dot transmissive large-sized liquid crystal display unit

RCM1383U

Thanks to the high contrast and wide viewing angle of the RCM1277N, which is provided by its unique design technology, this module brings forth new applications in brand new LCD fields. ROHM large-sized LCD units are perfect displays for information or sign boards. As a media for informational display, large-sized LCD units must possess high visibility, wide viewing angles, and other such superior qualities. ROHM large-sized LCDs boast an excellent track record and possess guaranteed functionality for assured satisfaction in a variety of situations.

●Applications

Public displays such as airport displays, train station displays, information boards, and billboards.

●Features

- 1) Wide viewing angle, high contrast, and fast response.
- 2) Compact and light weight for easy assembly.
- 3) Supports negative or positive display.
- 4) Low power consumption.

●External dimensions (Unit: mm)

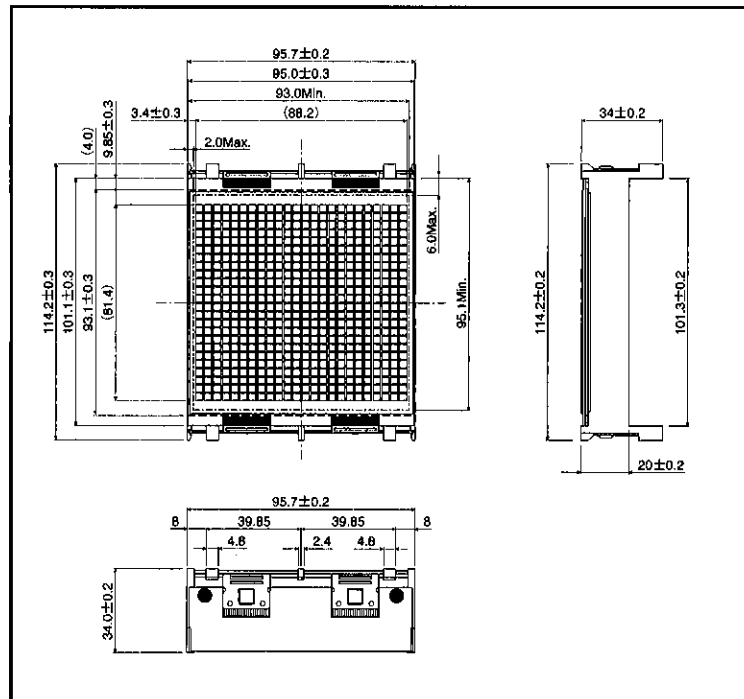

●Block diagram

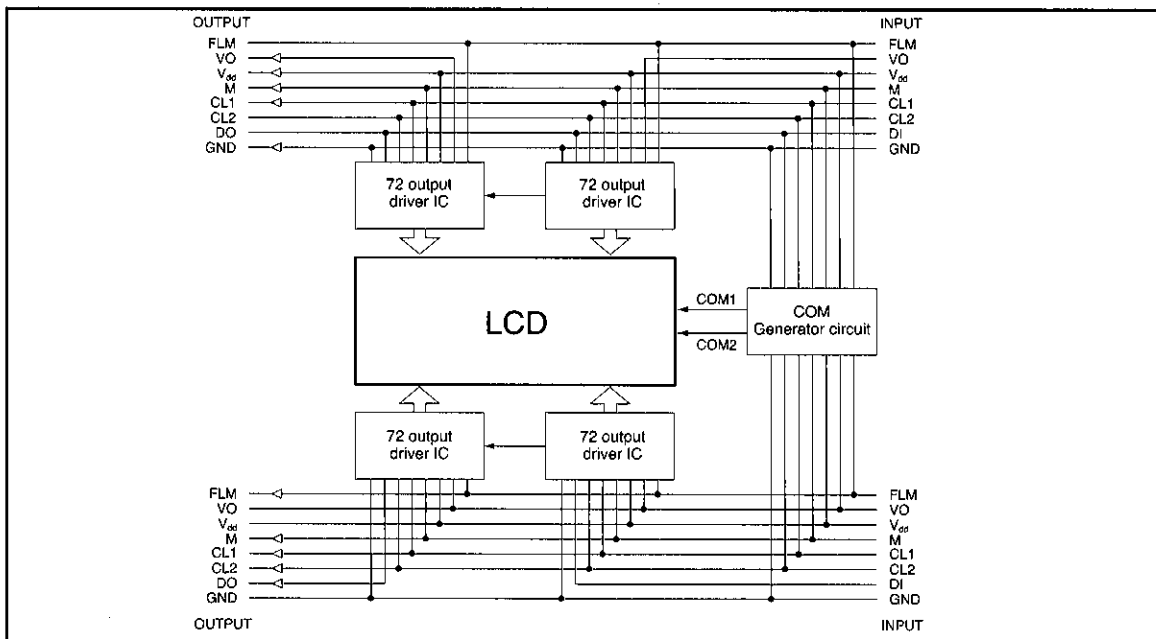

●Pin functions

(1) Upper board

Input (CN3)

Pin no.	Symbol	IN/OUT	Function
1	GND	—	Ground potential
2	DI	IN	Display data signal (1: On, 0: Off)
3	CL2	IN	Shift register shift signal, reads data at rise/fall
4	CL1	IN	Data latch signal, displays at rise/fall edge
5	M	IN	AC conversion signal for liquid crystal drive output
6	V _{dd}	—	5 volts
7	VO	—	Liquid crystal drive power supply
8	FLM	IN	Frame start signal

Output (CN4)

Pin no.	Symbol	IN/OUT	Function
1	GND	—	Ground potential
2	DO	OUT	Display data signal
3	CL2	OUT	Shift register shift signal
4	CL1	OUT	Data latch signal
5	M	OUT	AC conversion signal
6	V _{dd}	—	5 volts
7	VO	—	Liquid crystal drive power supply
8	FLM	OUT	Frame start signal

(2) Lower board

Input (CN1)

Pin no.	Symbol	IN/OUT	Function
1	FLM	IN	Frame start signal
2	VO	—	Liquid crystal drive power supply
3	V _{dd}	—	5 volts
4	M	IN	AC conversion signal for liquid crystal drive output
5	CL1	IN	Data latch signal, displays at rise/fall edge
6	CL2	IN	Shift register shift signal, reads data at rise/fall
7	DI	IN	Display data signal (1: On, 0: Off)
8	GND	—	Ground potential

Output (CN2)

Pin no.	Symbol	IN/OUT	Function
1	FLM	OUT	Frame start signal
2	VO	—	Liquid crystal drive power supply
3	V _{dd}	—	5 volts
4	M	OUT	AC conversion signal
5	CL1	OUT	Data latch signal
6	CL2	OUT	Shift register shift signal
7	DO	OUT	Display data signal
8	GND	—	Ground potential

● Absolute maximum ratings (Ta = 25°C)

Parameter	Symbol	Rating	Unit
Logic power supply voltage	V _{dd}	-0.3~7.0	V
LCD drive voltage	V _{dd} -V _O	-0.3~7.0	V
Input voltage	V _{IN}	-0.3~V _{dd} +0.3	V
Operating temperature range	T _{opr}	0~+50	°C
Storage temperature range	T _{stg}	-10~+60	°C

● Electrical characteristics (V_{DD} = 5.0 V ± 0.25 V, Ta = 25°C)

Parameter	Symbol	Min.	Typ.	Max.	Unit	Conditions
High level input voltage	V _{IH}	3.5	—	—	V	
Low level input voltage	V _{IL}	—	—	1.5	V	
High level output voltage	V _{OH}	4.6	—	—	V	I _{OH} = -0.4mA
Low level output voltage	V _{OL}	—	—	0.4	V	I _{OL} = +0.4mA
Power supply current	I _{DD}	—	3.0	10	mA	F _{CL} = 1MHz, F _M = 70Hz

● AC characteristics ($V_{dd} = 5.0\text{ V}$, $GND = 0\text{ V}$, $T_a = 25^\circ\text{C}$)

Parameter	Symbol	Applicable terminal	Min.	Typ.	Max.	Unit
Shift frequency	f_{CL}	CL2	—	—	5	MHz
High level lock width	t_{cWH}	CL1, CL2	470	—	—	ns
Low level lock width	t_{cWL}	CL2	470	—	—	ns
Data setup time	t_{SU}	DI	120	—	—	ns
Clock setup time 1	t_{SL}	CL2	220	—	—	ns
Clock setup time 2	t_{LS}	CL1	220	—	—	ns
Data hold time	t_{DH}	DI	120	—	—	ns
Clock rise/fall time	t_{cI}	CL1, CL2	—	—	50	ns
Output delay time	t_{pd}	DO	—	—	250	ns
AC conversion signal	f_M	M	—	70	—	HZ

● Timing characteristics

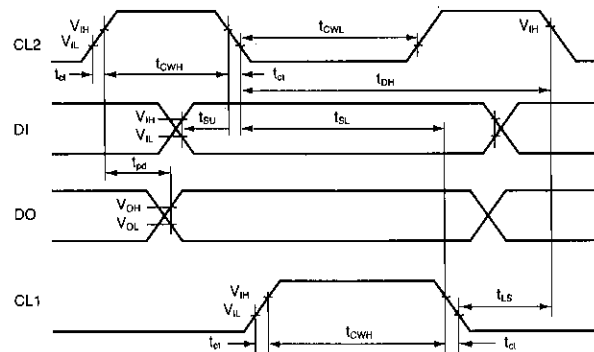

Fig.1

●Optical characteristics (Ta = 25°C)

NO.	Parameter	Symbol	Temperature (°C)	Min.	Typ.	Max.	Unit	Note
1	Response speed	Tr	25	—	65	130	ms	(Note 2)
		Td	25	—	45	100		
2	Viewing angle	Front-back	θ	25	0	—	deg	K ≥ 3 (Note 3)
		Right-left	φ	25	90	—		
3	Contrast ratio		25	3	5	—		(Note 4)

(Note 1) Drive waveform

Static drive

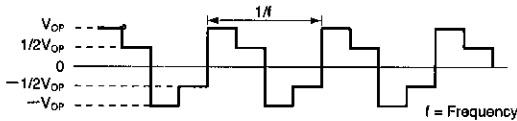

(Note 2) Definition of response speed

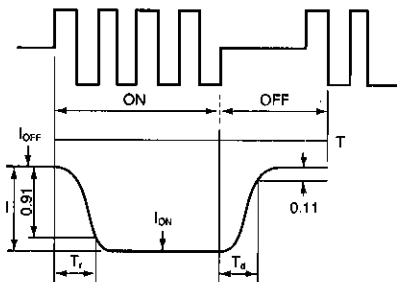

Tr : Time for segment to darken 90% after selective waveform switches to non-selective waveform.

$$\phi = 180^\circ, \theta = 10^\circ$$

Td : Time for segment to darken 90% after selective waveform switches to non-selective waveform.

$$\phi = 180^\circ, \theta = 10^\circ$$

(Note 3) Definition of viewing angle (φ, θ)

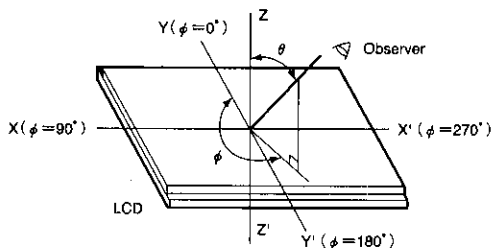

(1) φ : Angle subtended by the Y-Y'-axis and the observer's position projected onto the XY-plane.

(2) θ : Angle subtended by observer and the normal Z-Z'-axis (X-axis and Y-axis are positive)

(3) Maximum viewing angle : The direction with highest contrast expressed at the time axis (refer to above table).

(Note 4) Definition of contrast ratio

(Definition)

$$\text{Contrast ratio} = \left(\frac{\text{Luminance during application of non-selective waveform}}{\text{Luminance during application of selective waveform}} \right)^n$$

Except, n = 1 with positive display and n = -1 with negative display.

(Measurement conditions)

Drive conditions : As per specifications

Viewing angle : φ = 180°, θ = 10°

(Note 5) Principles of optical measuring equipment

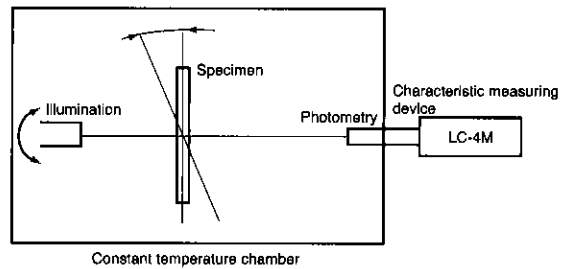

24 X 24 dot Large-sized Liquid Crystal Display Unit

●Data format (data and display mapping)

Upper

D1	D13	D25	---	---	---	---	---	---	---	D253	D265	D277
D2	D14	D26	---	---	---	---	---	---	---	D254	D266	D278
D3	D15	D27	---	---	---	---	---	---	---	D255	D267	D279
D4	D16	D28	---	---	---	---	---	---	---	D256	D268	D280
D5	D17	D29	---	---	---	---	---	---	---	D257	D269	D281
D6	D18	D30	---	---	---	---	---	---	---	D258	D270	D282
D7	D19	D31	---	---	---	---	---	---	---	D259	D271	D283
D8	D20	D32	---	---	---	---	---	---	---	D260	D272	D284
D9	D21	D33	---	---	---	---	---	---	---	D261	D273	D285
D10	D22	D34	---	---	---	---	---	---	---	D262	D274	D286
D11	D23	D35	---	---	---	---	---	---	---	D263	D275	D287
D12	D24	D36	---	---	---	---	---	---	---	D264	D276	D288

Lower

D1	D13	D25	---	---	---	---	---	---	---	D253	D265	D277
D2	D14	D26	---	---	---	---	---	---	---	D254	D266	D278
D3	D15	D27	---	---	---	---	---	---	---	D255	D267	D279
D4	D16	D28	---	---	---	---	---	---	---	D256	D268	D280
D5	D17	D29	---	---	---	---	---	---	---	D257	D269	D281
D6	D18	D30	---	---	---	---	---	---	---	D258	D270	D282
D7	D19	D31	---	---	---	---	---	---	---	D259	D271	D283
D8	D20	D32	---	---	---	---	---	---	---	D260	D272	D284
D9	D21	D33	---	---	---	---	---	---	---	D261	D273	D285
D10	D22	D34	---	---	---	---	---	---	---	D262	D274	D286
D11	D23	D35	---	---	---	---	---	---	---	D263	D275	D287
D12	D24	D36	---	---	---	---	---	---	---	D264	D276	D288

FIRST DATA ←

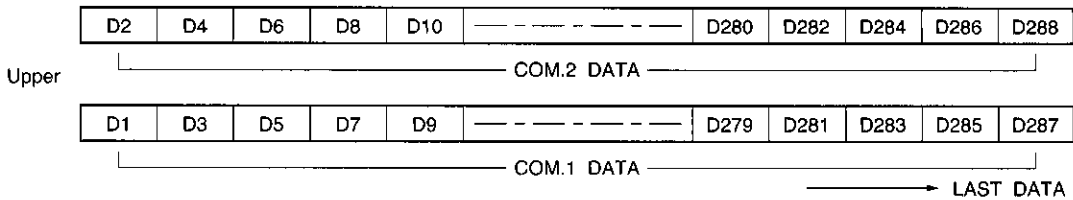

FIRST DATA ←

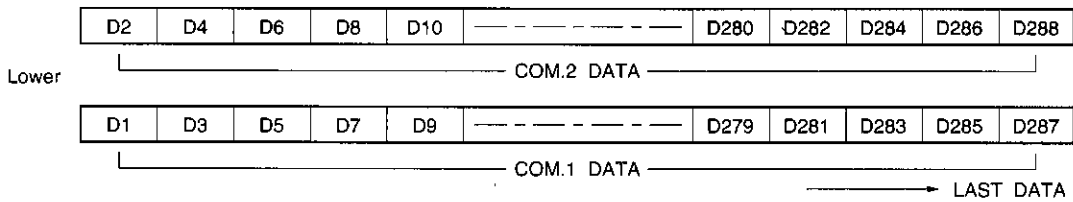

● Timing chart

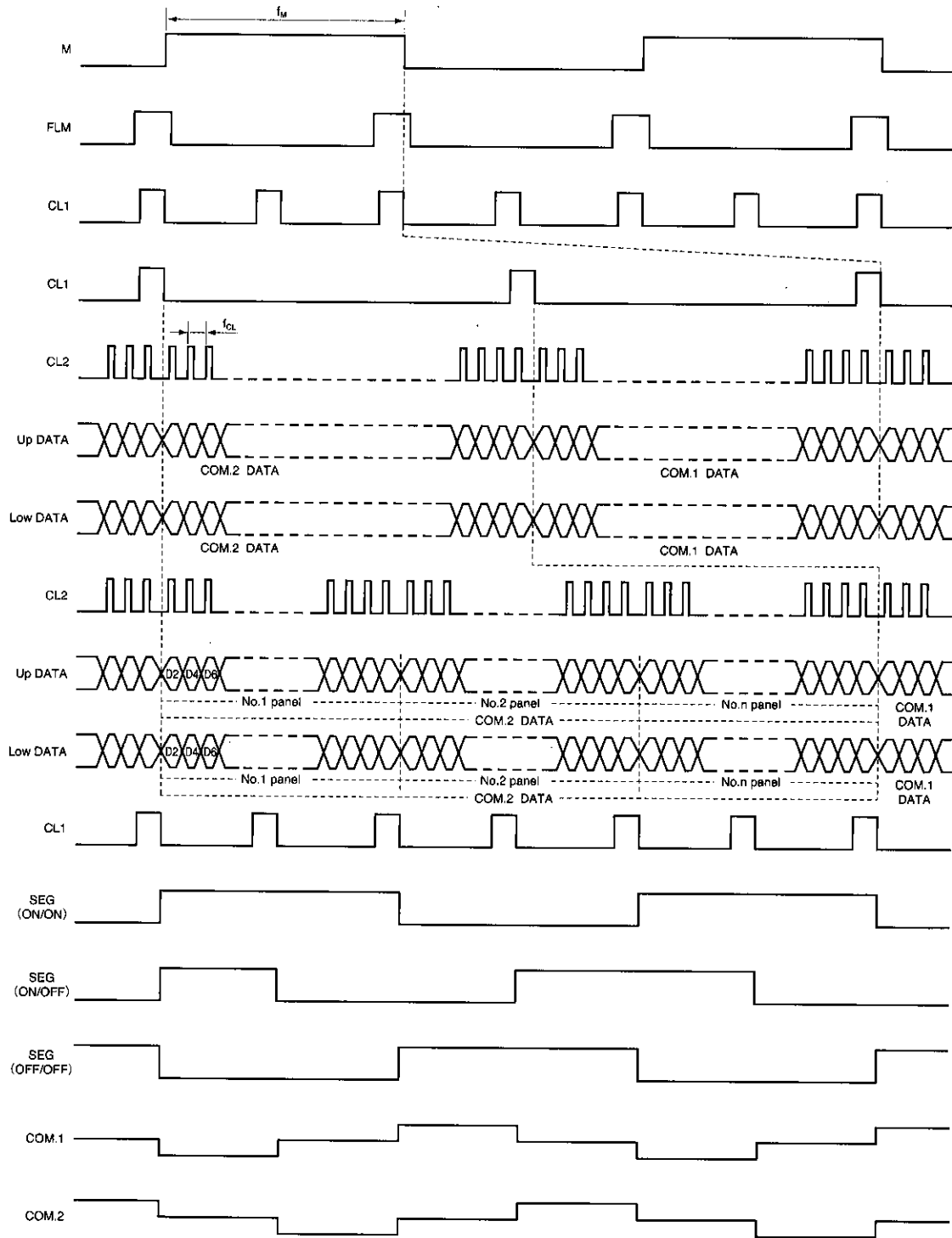

24 x 24 dot

Large-sized Liquid Crystal Display Unit

●Precautions during use**(1) handling precautions**

- Protect the module from strong shocks as they can cause damage or defective operation.
- The polarizing plate on the surface of the module is soft and can easily be scratched. Wipe away dirt and dust using an alcohol-based cleanser.
- If the liquid crystal panel is damaged and liquid crystal contacts your clothing or body, wash immediately with soap and water.
- If the module is to be used for long periods subjected to direct sunlight, employ a filter to block the ultraviolet rays.
- Do not store the module in areas of high temperature or high humidity. Do not store the module in locations exposed to direct sunlight or fluorescent light.

(2) Precautions during operation

- Do not connect or disconnect the module while the power supply is turned on.
- Input the input signal after the module's power supply is turned on. When turning it off, turn off the input signal first. Otherwise the IC may be damaged by the latch up development.

(3) Precautions during installation

- Be careful to avoid damage from static electricity. A CMOS-IC is used in the modules circuitry that can be easily damaged by static electricity.
- Do not remove the liquid crystal panel from the unit.
- Do not touch the back side of the liquid crystal panel.

(4) Precautions during unit assembly

- In order to protect the polarizing plate from dirt or scratches, it is recommended to use a protective cover on the front surface.

Notes

- The contents described in this catalogue are correct as of March 1997.
- No unauthorized transmission or reproduction of this book, either in whole or in part, is permitted.
- The contents of this book are subject to change without notice. Always verify before use that the contents are the latest specifications. If, by any chance, a defect should arise in the equipment as a result of use without verification of the specifications, ROHM CO., LTD., can bear no responsibility whatsoever.
- Application circuit diagrams and circuit constants contained in this data book are shown as examples of standard use and operation. When designing for mass production, please pay careful attention to peripheral conditions.
- Any and all data, including, but not limited to application circuit diagrams, information, and various data, described in this catalogue are intended only as illustrations of such devices and not as the specifications for such devices. ROHM CO., LTD., disclaims any warranty that any use of such device shall be free from infringement of any third party's intellectual property rights or other proprietary rights, and further, assumes absolutely no liability in the event of any such infringement, or arising from or connected with or related to the use of such devices.
- Upon the sale of any such devices; other than for the buyer's right to use such devices itself, resell or otherwise dispose of the same; no express or implied right or license to practice or commercially exploit any intellectual property rights or other proprietary rights owned or controlled by ROHM CO., LTD., is granted to any such buyer.

The products listed in this catalogue are designed to be used with ordinary electronic equipment or devices (such as audio-visual equipment, office-automation equipment, communications devices, electrical appliances, and electronic toys). Should you intend to use these products with equipment or devices which require an extremely high level of reliability and the malfunction of which would directly endanger human life (such as medical instruments, transportation equipment, aerospace machinery, nuclear-reactor controllers, fuel controllers, or other safety devices) please be sure to consult with our sales representatives in advance.

- Notes when exporting
 - It is essential to obtain export permission when exporting any of the above products when it falls under the category of strategic material (or labor) as determined by foreign exchange or foreign trade control laws.
 - Please be sure to consult with our sales representatives to ascertain whether any product is classified as a strategic material.